

REV.	DATE	DCN #	DRAWING TREE #
A	6 AUG 2008	E080422-00-D	

2X 8-32 UNC - 2B THRU  
+.005 OVERSIZE TAP

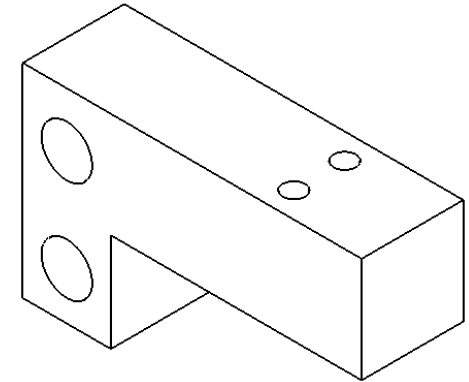

2X  $\phi$ .38 THRU

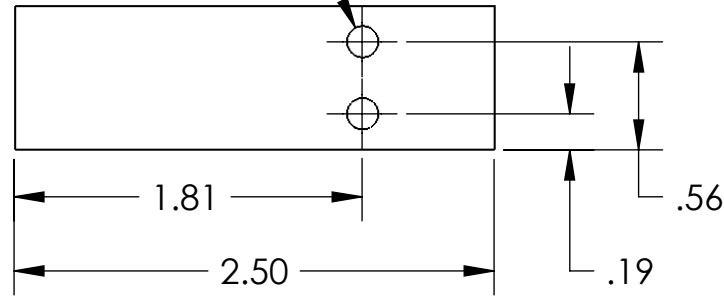
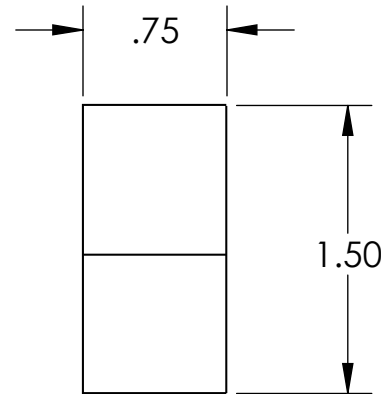
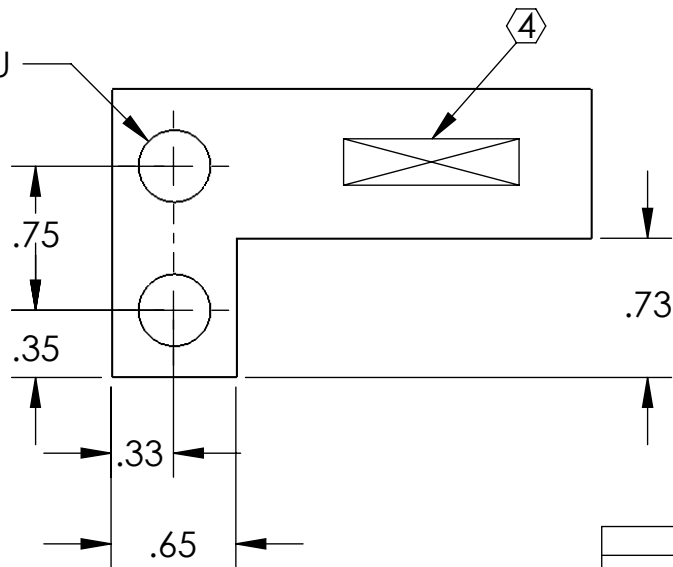

NOTES: (UNLESS OTHERWISE SPECIFIED)

- DO NOT SCALE FROM DRAWING.
- REMOVE ALL SHARP EDGES, R.02 MAX.
- ALL MACHINING FLUIDS SHALL BE WATER SOLUBLE AND FREE OF SULFUR, CHLORINE AND SILICONE.

④ SCRIBE, ENGRAVE OR MECHANICALLY STAMP DRAWING (NO INKS OR DYES) PART NUMBER, REVISION ON NOTED SURFACE OF PART FOLLOWED ON THE NEXT LINE WITH A THREE DIGIT SERIAL NUMBER. SERIAL NUMBERS START AT 001 FOR THE FIRST ARTICLE AND PROCEED CONSECUTIVELY. USE .12" HIGH CHARACTERS, UNLESS THE SIZE OF THE PART DICTATES SMALL CHARACTERS. A VIBRATORY TOOL MAY BE USED. EXAMPLE:  
D050XXX-A  
S/N 001

DIMENSIONS ARE IN INCHES

TOLERANCES:

.XX ± 0.03

.XXX ± 0.005

ANGULAR ± 0.5 °

MATERIAL

6061-T6 AL

FINISH

63 μ inch

	NAME	DATE
DRAWN	M. MEYER	23 JUL 2008
CHECKED	J. ROMIE	6 AUG 2008
APPROVED		



SYSTEM ADVANCED LIGO

SUB-SYSTEM SUS

NEXT ASSY TT STRUCTURE ASSY

PART NAME PASSIVE ECD MOUNT

SIZE DWG. NO. D080450

REV. A

SCALE: 1:1 PROJECTION: SHEET 1 OF 1