

LIGO Laboratory / LIGO Scientific Collaboration

LIGO-T0900249-v2

Advanced LIGO UK

22 October 2009

UIM Drive Unit Users' Guide

R. M. Cutler, University of Birmingham

Distribution of this document:
Inform `aligo_sus`

This is an internal working note
of the Advanced LIGO Project, prepared by members of the UK team.

**Institute for Gravitational Research
University of Glasgow**

Phone +44 (0) 141 330 5884

Fax +44 (0) 141 330 6833

E-mail k.strain@physics.gla.ac.uk

Engineering Department

CCLRC Rutherford Appleton Laboratory

Phone +44 (0) 1235 445 297

Fax +44 (0) 1235 445 843

E-mail J.Greenhalgh@rl.ac.uk

**School of Physics and Astronomy
University of Birmingham**

Phone +44 (0) 121 414 6447

Fax +44 (0) 121 414 3722

E-mail av@star.sr.bham.ac.uk

Department of Physics

University of Strathclyde

Phone +44 (0) 1411 548 3360

Fax +44 (0) 141 552 2891

E-mail N.Lockerbie@phys.strath.ac.uk

<http://www.ligo.caltech.edu/>

<http://www.physics.gla.ac.uk/igr/sus/>

<http://www.sr.bham.ac.uk/research/gravity/rh,d,2.html>

http://www.eng-external.rl.ac.uk/advligo/papers_public/ALUK_Homepage.htm

UIM Driver Users Guide

Contents

- 1. Document Organization**
- 2. LIGO**
 - 2.1 The Mirror Suspension System**
 - 2.2 The UIM Control System**
- 3 The UIM Drive Unit**
 - 3.1 The Drive card**
 - 3.2 The Monitor Card**
- 4 Using the Unit**
 - 4.1 Connectors**
 - 4.2 Connector Functions**
 - 4.2.1 Connectors on the Front Panel**
 - 4.2.2 Connectors on the Rear Panel**
 - 4.3 Connector Details**
- 5. Functional description**
 - 5.1 Inside the Unit**
 - 5.2 The Drive Board**
 - 5.3 Monitor Board**
- 6. References**

1. DOCUMENT ORGANIZATION

- Section 1 introduces the LIGO suspensions
- Section 2 describes the UIM control system, and the function of the UIM Drive Unit within the control system.
- Section 3 describes the UIM Drive Unit
- Section 4 describes how to use the unit, and details how the UIM Drive Unit connections to the rest of the system,
- Section 5 gives a functional description

2 LIGO

The LIGO (Laser Interferometric Gravitational-wave Observatory) experiment is designed to detect gravity waves.

The laser interferometry method used involves mirrors which are held in a steady position to a very high degree of precision.

2.1 The Mirror Suspension System

Mirror stability is achieved by means of a suspension consisting of 4 heavy masses which form a compound pendulum. The position and movement of the top three stages is controlled electromagnetically, while the bottom stage on which the mirror is mounted, is controlled electrostatically.

The purpose of position control is to maintain the output of the interferometer on a dark fringe. Movement control also damps the low frequency pendulum modes.

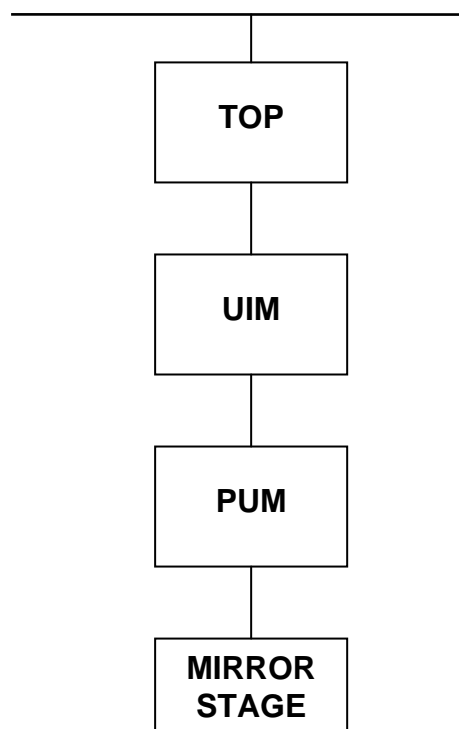

FIG 1 The LIGO Quad suspension.

2.2 The UIM Control System

The UIM Driver forms part of the control system which controls the position and movement of the UIM stage electromagnetically. Fig 2 is a simplified diagram of the control system, illustrating the role of the Driver Unit.

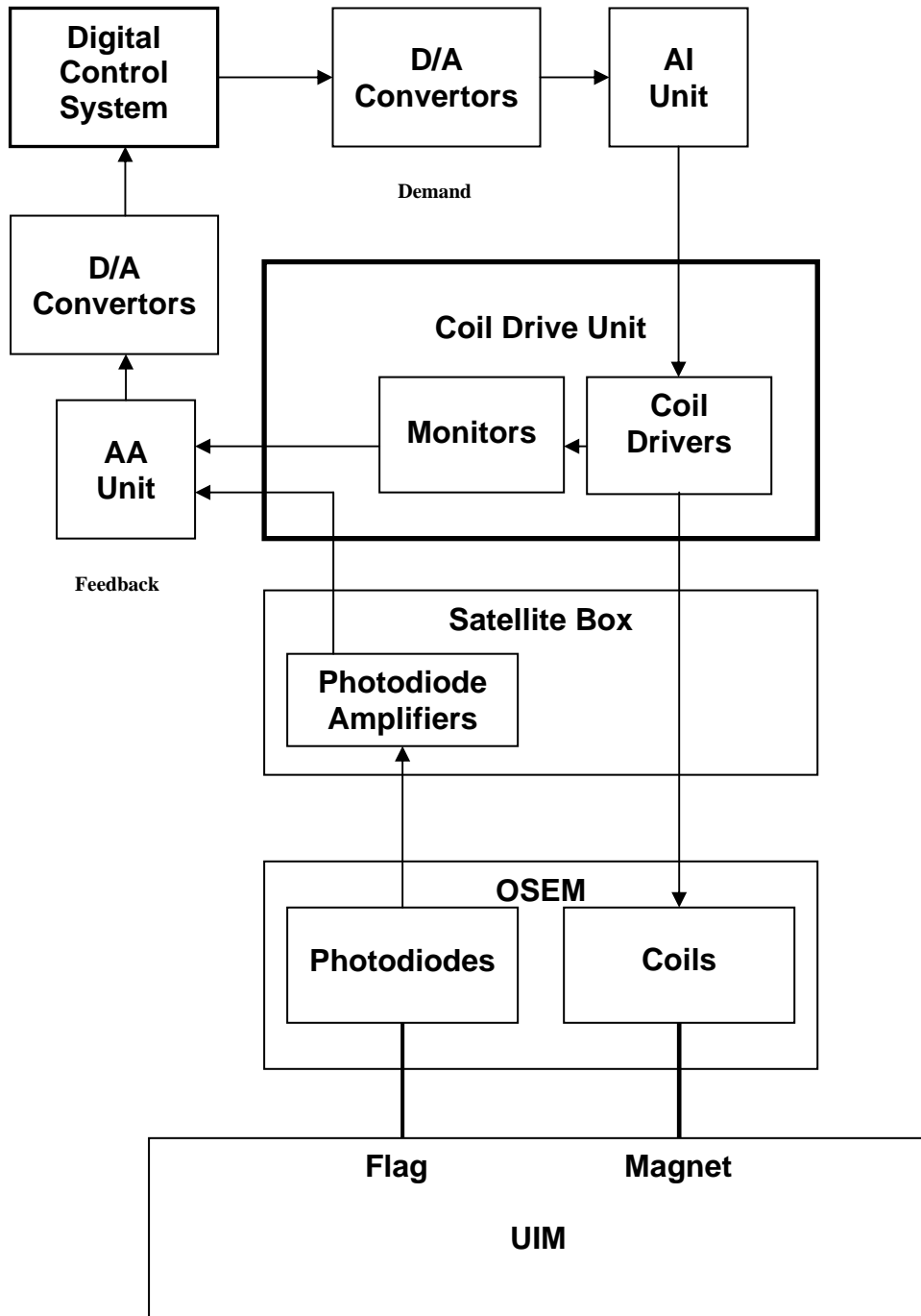

Fig 2 The UIM Control System

The demand signals to the Drive Amplifiers are generated by the Digital Control System, converted to analogue signals, and then filtered in the AI Unit. The signals are then amplified and filtered by the Drive Amplifiers and pass through the Satellite Box to provide the demanded currents to the drive

coils. The position of the UIM is indicated by mechanical “flags” to the OSEM optical position detectors. The position detectors consist of LED and photodiode pairs. The photodiode outputs are amplified in the Satellite Box, and then fed back to the Digital Control System via the filters in the AA unit to the A/D convertors.

3 THE UIM DRIVE UNIT

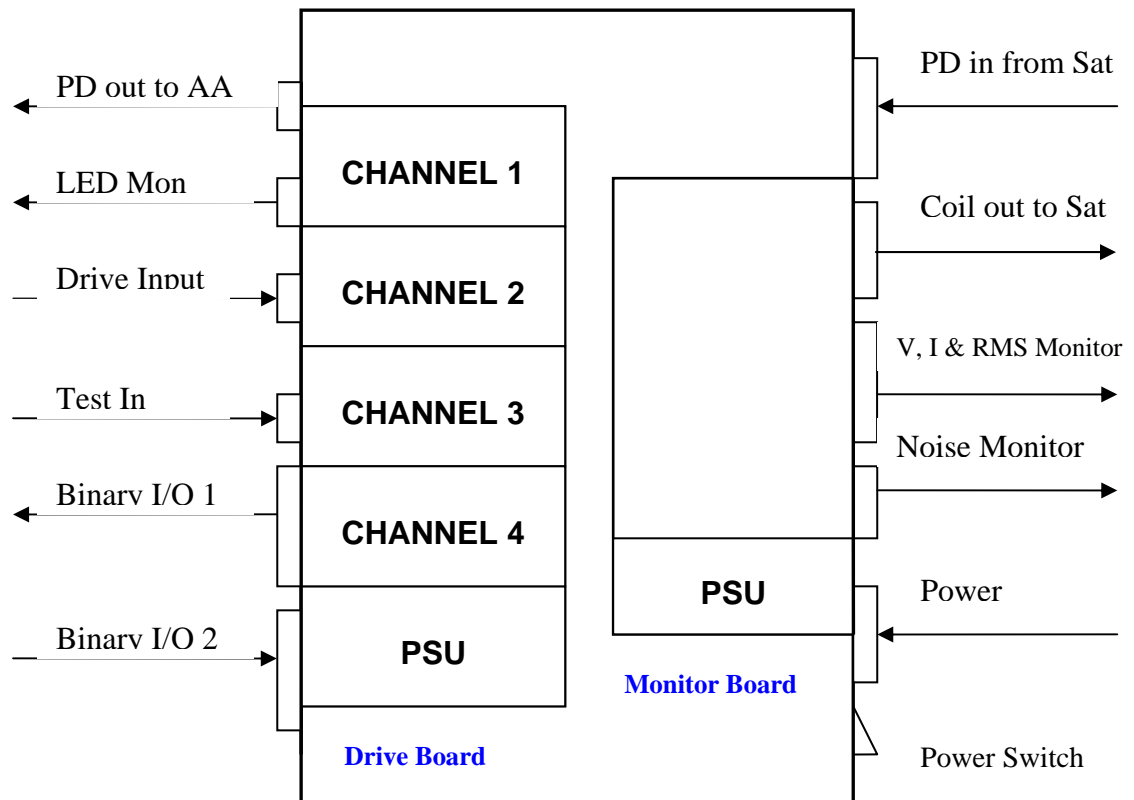

Fig 3 The UIM Driver unit

The UIM Driver unit houses a Drive Card and a Monitor Card. Each of these cards has four channels.

3.1 The Drive Card

The Drive Card performs amplification and filtering of the demand signals. The filter stages may be switched in or out by the relay control signals on Binary I/O 2, to give a selected trade off between noise and dynamic range. The state of these relays is monitored by Binary I/O 1.

Each filter stage acts as a low pass filter with a 1 Hz corner frequency. Each filter also has a “zero” at 10 Hz, so its attenuation is almost constant above 10 Hz. A boost circuit on the output raises the gain above 10 Hz to increase the dynamic range at 100Hz.

3.2 The Monitor Card

The monitor card monitors the performance of the Driver, presenting the output Voltage, instantaneous Current and RMS current to the A/D circuits via the AA Unit. The output voltage noise from the amplifiers is also presented, after amplification, via a separate output connector.

4. USING THE UNIT

To use the unit, first connect it to the system as described below. The power switch should be in the "off" position at this stage (0). The input voltage should be checked before connection (Positive voltage = 17v nominal, 16.5 v minimum, 18v maximum, negative voltage = -17v nominal, -16.5 volts minimum, 18 volts maximum.) and A1 = positive, A2 = return, A3 = negative. Having connected all the cables correctly and checked the power supply, the power may be switched on. The green LED indicator lights on the front and rear panels should then become illuminated, indicating that the on board regulators are operating.

The unit should not be used with the inputs floating. For this reason, the Test input is supplied with a shorting plug, which should be left in place. When the unit is switched on, it automatically goes into test mode.

The unit should not be operated without being connected to a signal source. Doing so should not damage the unit, but the output voltages would be unpredictable, causing uncontrolled voltages to appear across the load.

It is possible connect both the Test and Drive inputs to ground via a resistor if desired. This is done by closing links W6 or W2 inside the unit, on each channel. However operating the unit in situ like this is likely to cause earth loops, and may result in excessive output noise.

4.1 Connectors

The input and output connections to the UIM Drive Unit were shown on Figure 3. Details of these connectors follow.

4.2 Connector Functions

The unit needs to be connected to the system in the following way.

4.2.1 Connectors on the Front Panel

These will now be described starting from the left hand connector.

PD Out to AA socket

This needs to be connected to the AA unit. It transmits the photodiode outputs via the AA unit to the A/D converters and control system.

LED Mon socket

This needs to be connected to the A/D converters via the AA unit. It consists of the signals which monitor the state of the LEDs in the satellite box.

Drive Input plug

This needs to be connected to the Coil demand signal from the D/A Converter, unit via the AI unit. The signals which are fed in to this plug determine the coil drive current.

Test plug

This must normally be terminated by a shorting socket, with all connections joined together. It may also be used to feed demand signals in for test purposes.

Binary I/O 1 socket

The signals on this socket are used to monitor the status of the filter relays and the Test relay.

Binary I/O 2 plug

This connector is used to control the state of the relays which switch the filters in and out. It also indicates the state of the relays which switch the Drive Amplifier inputs between the Drive Inputs and the Test Inputs.

4.2.2 Connectors on the Rear Panel

Starting from the left hand end of the rear panel:

Switch/Thermal cut out

This controls the DC power input to the unit. It incorporates a thermal cut out to protect against a prolonged over current situation.

DC In plug

This 4 pin heavy duty 'D' connector is to be connected to the power supply. The nominal input voltage is +/-17 volts.

Noise Monitor socket

This presents the outputs from the Noise Monitor circuits, and should be connected to the A/D converters via the AA unit.

V, I and RMS monitor plug

This presents the outputs from the Voltage Monitor, Current Monitor and R.M.S Monitor circuits, and should be connected to the A/D converters, via the AA unit.

Coil Out to Sat socket

This connector is the output to the coils in the OSEMs. The cable from this connector is connected to the Satellite box. The signals pass through the Satellite Box then out to the coils via a separate connector on the satellite box.

PD In from Sat socket

This is connected to the satellite box, which generates the amplified Photo Diode (PD) signals. The PD outputs pass straight through the Drive Unit then out to the AA unit.

4.3 Connector Details

PD Out to AA:

Type: 9 Way Socket. **Connections:** Differential pairs.

Voltage range: +/-10v per line = +/-20v differential.

Calibration: 0.3233V differential per μA photodiode current. 60 μA gives 19.4v differential output.

Connections:

Pin	Function
1	PD1 Positive
2	PD2 Positive
3	PD3 Positive
4	PD4 Positive
5	0v
6	PD1 Negative
7	PD2 Negative
8	PD3 Negative
9	PD4 Negative

LED Mon

Type: 9 Way Socket.

Voltage range: 10v. **Nominal output = 1v**

Connections:

Pin	Function
1	Imon 1 Positive
2	Imon 2 Positive
3	Imon 3 Positive
4	Imon 4 Positive
5	0v
6	Imon 1 Negative
7	Imon 2 Negative
8	Imon 3 Negative
9	Imon 4 Negative

Drive Inputs

Type: 9 Way Plug. **Connections:** Differential pairs.

Voltage range: +/-10v per line = +/-20v differential.

Connections:

Pin	Function
1	Input 1 Positive
2	Input 2 Positive
3	Input 3 Positive
4	Input 4 Positive
5	0v
6	Input 1 Negative
7	Input 2 Negative
8	Input 3 Negative
9	Input 4 Negative

Test Inputs

Type: 9 Way Plug, Differential pairs.

Voltage range: +/-10v per line = +/-20v differential.

Note: This connector must be connected to a shorting connector when test are not being carried out.

Connections:

Pin	Function
1	Test Input 1 Positive
2	Test Input 2 Positive
3	Test Input 3 Positive
4	Test Input 4 Positive
5	0v
6	Test Input 1 Negative
7	Test Input 2 Negative
8	Test Input 3 Negative
9	Test Input 4 Negative

Binary IO 1

Type: 37 Way Socket

Single ended with respect to 0v

+12v indicates that the relay is on.

0v indicates that the relay is switched off.

Pin	Name	Function
1	LP1on1	Low Pass Filter 1, channel 1 on
2	LP2on1	Low Pass Filter 2, channel 1 on
3	LP3on1	Low Pass Filter 3, channel 1 on
4	Test Mode1	Test Mode relay 1 on
5	LP1on2	Low Pass Filter 1, channel 2 on
6	LP2on2	Low Pass Filter 2, channel 2 on
7	LP3on2	Low Pass Filter 3, channel 2 on
8	Test Mode2	Test Mode relay 2 on
9	LP1on3	Low Pass Filter 1, channel 3 on
10	LP2on3	Low Pass Filter 2, channel 3 on
11	LP3on3	Low Pass Filter 3, channel 3 on
12	Test Mode3	Test Mode relay 3 on
13	LP1on4	Low Pass Filter 1, channel 4 on
14	LP2on4	Low Pass Filter 2, channel 4 on
15	LP3on4	Low Pass Filter 3, channel 4 on
16	Test Mode4	Test Mode relay 4 on
17	0v	
18	0v	
19	0v	
20	0v	
21	0v	
22	0v	
23	0v	
24	0v	
25	0v	
26	0v	
27	0v	
28	0v	
29	0v	
30	0v	
31	0v	
32	0v	
33	0v	
34	0v	
35	0v	
36	0v	
37	0v	

Binary IO 2 – Relay Control

Type: 37 Way Plug

Single ended with respect to 0v

0v turns the relay on

Open circuit switches the relay off.

Pin	Name	Function
1	LP11	Low Pass Filter 1, channel 1
2	LP21	Low Pass Filter 2, channel 1
3	LP31	Low Pass Filter 3, channel 1
4	Test1	Test Input 1
5	LP12	Low Pass Filter 1, channel 2
6	LP22	Low Pass Filter 2, channel 2
7	LP32	Low Pass Filter 3, channel 2
8	Test2	Test Input 2
9	LP13	Low Pass Filter 1, channel 3
10	LP23	Low Pass Filter 2, channel 3
11	LP33	Low Pass Filter 3, channel 3
12	Test3	Test Input 3
13	LP14	Low Pass Filter 1, channel 4
14	LP24	Low Pass Filter 2, channel 4
15	LP34	Low Pass Filter 3, channel 4
16	Test4	Test Input 4
17		
18		
19		
20	0v	
21	0v	
22	0v	
23	0v	
24	0v	
25	0v	
26	0v	
27	0v	
28	0v	
29	0v	
30	0v	
31	0v	
32	0v	
33	0v	
34	0v	
35	0v	
36	0v	
37	0v	

DC In: Power cable:**Type:** 3 pin heavy duty **Voltages:** Nominally +/- 17volts from Power supply

Pin	Position	Function
A1	Left viewed from rear	Positive
A2	Centre	RTN
A3	Right viewed from rear	Negative

Noise Monitor**Type:** 9 Way Socket. Differential pairs, ac coupled filtered, amplified noise.

Pin	Function
1	Noise Monitor 1
2	Noise Monitor 2
3	Noise Monitor 3
4	Noise Monitor 4
5	0v
6	0v
7	0v
8	0v
9	0v

V, I and RMS monitor (Pre Production model only)**Type:** 25 way socket. Voltage, Current, and RMS Monitors.**Voltage range:** +/-10v per line = +/-20v differential.

Pin	Name	Function
1	VM4	Channel 4 Voltage monitor
2	FC4	Channel 4 Current monitor
3	SC4	Channel 4 RMS monitor
4	VM3	Channel 3 Voltage monitor
5	FC3	Channel 3 Current monitor
6	SC3	Channel 3 RMS monitor
7	VM2	Channel 2 Voltage monitor
8	FC2	Channel 2 Current monitor
9	SC2	Channel 2 RMS monitor
10	VM1	Channel 1 Voltage monitor
11	FC1	Channel 1 Current monitor
12	SC1	Channel1 RMS monitor
13	0v	
14	0v	
15	0v	
16	0v	
17	0v	
18	0v	
19	0v	
20	0v	
21	0v	
22	0v	
23	0v	
24	0v	
25	0v	

V, I and RMS monitor - Production model

Type: 25 way plug. Voltage, Current, and RMS Monitors.

Voltage range: +/-10v per line = +/-20v differential.

Pin	Name	Function
1	SC1	Channel 1 RMS monitor
2	FC1	Channel 1 Current monitor
3	VM1	Channel 1 Voltage monitor
4	SC2	Channel 2 RMS monitor
5	FC2	Channel 2 Current monitor
6	VM2	Channel 2 Voltage monitor
7	SC3	Channel 3 RMS monitor
8	FC3	Channel 3 Current monitor
9	VM3	Channel 3 Voltage monitor
10	SC4	Channel 4 RMS monitor
11	FC4	Channel 4 Current monitor
12	VM4	Channel 4 Voltage monitor
13	0v	
14	0v	
15	0v	
16	0v	
17	0v	
18	0v	
19	0v	
20	0v	
21	0v	
22	0v	
23	0v	
24	0v	
25	0v	

Coil Out to Sat: **Type:** 15 way socket. Drive to the OSEM coils, delivered via the satellite box. Current output, 3mA maximum, differential drive.

Pin	Name	Function
1	CoilST1	Coil 1 Start
2	0v	
3	CoilST2	Coil 2 Start
4	0v	
5	CoilST3	Coil 3 Start
6	0v	
7	CoilST4	Coil 4 Start
8	0v	
9	CoilFN1	Coil 1 Finish
10	0v	
11	CoilFN2	Coil 2 Finish
12	0v	
13	CoilFN3	Coil 3 Finish
14	0v	
15	CoilFN4	Coil 4 Finish

PD in from SAT

Type: 25 way socket. Differential Photodiode outputs from the satellite box

Voltage range: +/-10v per line = +/-20v differential.

Current monitor outputs from the satellite box: 1v nominal

Power Supplies to the Satellite Box: +/- 17v nominal

Connections:

Pin	Name	Function
1	PD1P	Photodiode output channel 1 Positive
2	PD2P	Photodiode output channel 2 Positive
3	PD3P	Photodiode output channel 3 Positive
4	PD4P	Photodiode output channel 4 Positive
5	Imon1P	LED Current Monitor 1 Positive
6	Imon2P	LED Current Monitor 2 Positive
7	Imon3P	LED Current Monitor 3 Positive
8	Imon4P	LED Current Monitor 4 Positive
9	V+	Satellite Box Raw Positive Supply
10	V+	Satellite Box Raw Positive Supply
11	V-	Satellite Box Raw Negative Supply
12	V-	Satellite Box Raw Negative Supply
13	0v	
14	PD1N	Photodiode output channel 1 Negative
15	PD2N	Photodiode output channel 2 Negative
16	PD3N	Photodiode output channel 3 Negative
17	PD4N	Photodiode output channel 4 Negative
18	Imon1N	LED Current Monitor 1 Negative
19	Imon2N	LED Current Monitor 2 Negative
20	Imon3N	LED Current Monitor 3 Negative
21	Imon4N	LED Current Monitor 4 Negative
22	0v	Satellite Box 0v
23	0v	Satellite Box 0v
24	0v	Satellite Box 0v
25	0v	Satellite Box 0v

5 FUNCTIONAL DESCRIPTION

5.1 Inside the Unit

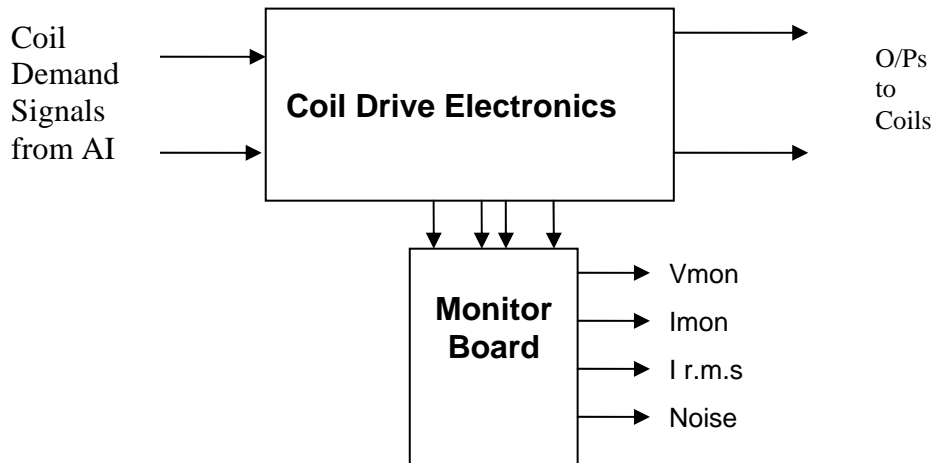

FIG. 4 UIM Driver Unit Block Diagram

The UIM Coil Drive Unit contains a Coil Drive board and a Monitor board. The purpose of the Monitor Board is to monitor the Output voltage, Output Current, RMS Current and Output Noise from unit.

The UIM Driver Unit also passes the amplified signals from the Photodiodes, which detect the position of the UIM mirror, back to the control electronics without processing them in any way.

5.2 The Drive Board

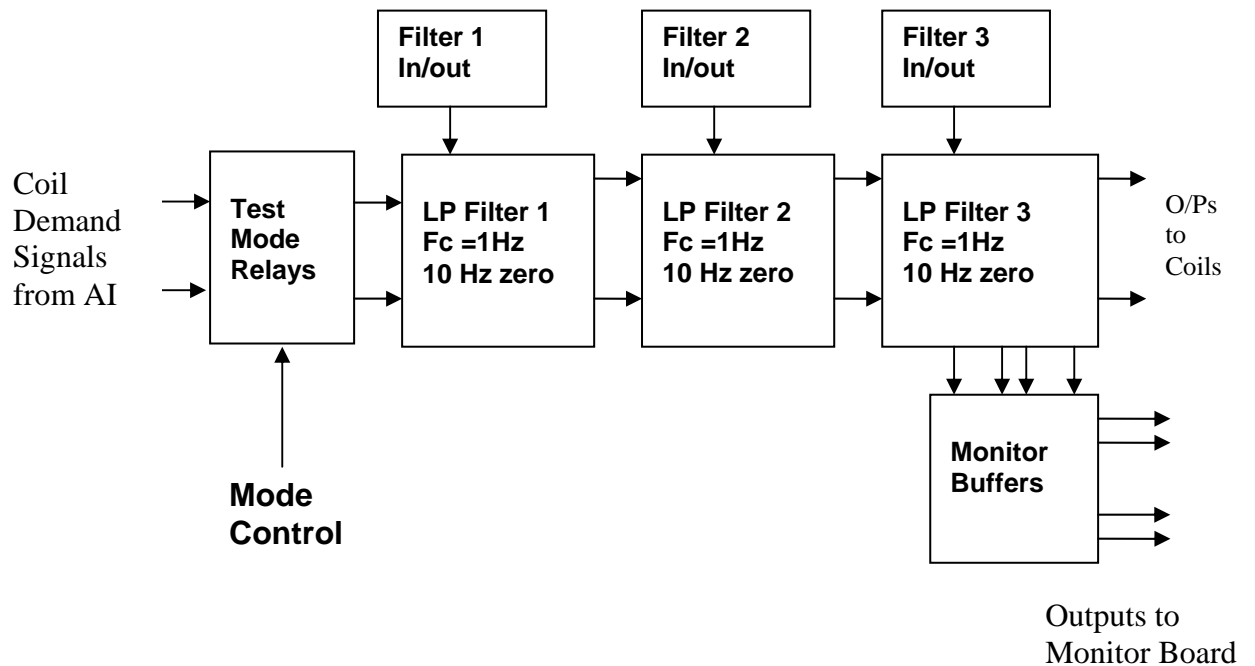

FIG.5 UIM Driver Channel Block Diagram

Each UIM Driver board consists of four identical channels, one of which is shown above. Three power regulators (not shown), which provide regulated power to the four channels, are also mounted on the board.

Taking the diagram block by block, the first block contains relays which switch the circuit between the demand inputs and the test inputs.

The second block contains a low pass filter with a corner frequency of 1 Hz, followed by a complimentary zero at 10 Hz. To a good approximation, the gain is reduced by a factor of 0.7 at 1 Hz, the attenuation increases at a rate of 20dB/decade up to the corner frequency of the zero at 10 Hz, after which the characteristic levels off. The forth block is again similar, except that it has a gain of 1.248. The overall gain of the UIM driver is 1.2. The extra gain is needed to compensate for the losses in the switching circuits due to 1 Meg bypass resistors and associated capacitors, which prevent switching transients.

Finally, the outputs from the driver stage, and the voltage across the coil, are both buffered by unity gain voltage followers before being fed to the monitor circuit.

Each filter may be switched in and out as required by its own control relay, and a talkback signal confirms the position of each relay.

The Test Mode relay provided on the front end enables the amplifier inputs to be switched to the Test input when required.

5.3 Monitor Board

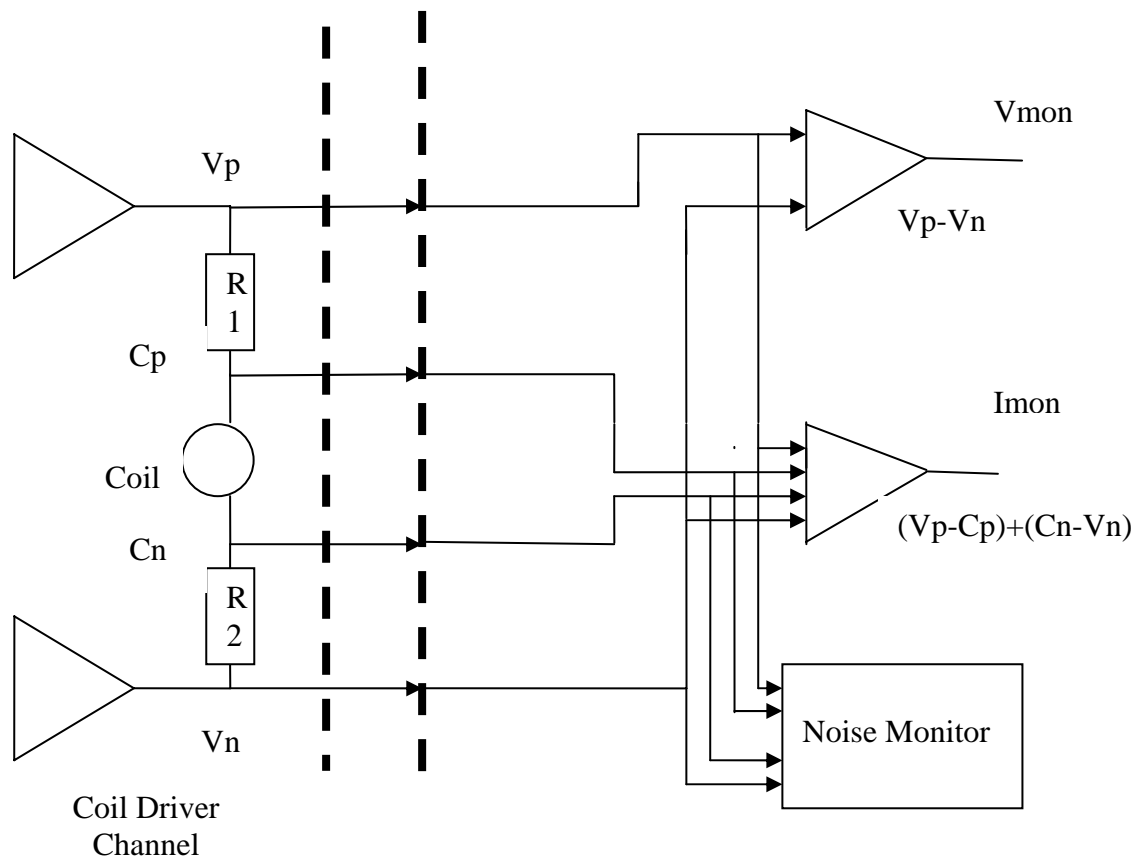

Fig 6 Block diagram of one channel of the monitor board.

Description

The function of the Monitor Board is to monitor the outputs from a drive board. It has four identical channels, one per drive board channel.

Inputs

The inputs of the monitor Board are connected to the two amplifier outputs and the coil feeds.

The following signals are monitored on each channel. They are: the positive and negative output voltages from the drive amplifiers, and the positive and negative output voltages developed across the coil.

These four signals are used to derive the amplifier output voltage, the current through the coil and the output noise on each of the drive amplifier channels.

Output Voltage

The Amplifier Output Voltage is measured by subtracting the Positive Amplifier output from the Negative Amplifier Output. The output is scaled by a factor of 3, so, for example, inputs of +15v and -15v, the sum of which is 30v, would give an output of $30\text{v}/3 = 10\text{v}$.

Coil Current

The coil current is monitored by measuring the sum of the voltages across the two output resistors (R1 and R2 on the block diagram.) The amplifier performs the following calculation:

$$\frac{\{(\text{Pos Voltage Output}) - (\text{Negative Voltage Output})\}}{\{(\text{Pos Coil Voltage}) - (\text{Negative Coil Voltage})\}}$$

The voltage across the coil is subtracted from the voltage across the Amplifier output. This gives the voltage across the output resistors, which is proportional the coil current.

An R.M.S. converter chip calculates the true R.M.S. output current. The overall scaling factor of the R.M.S. converter and amplifier circuits is 1/3.

Noise Measurement

As the noise level amounts to a few Pico amperes, it is extremely difficult to measure directly. Instead, the noise voltage across the amplifier outputs is monitored. This enables the coil noise current to be estimated. Four amplifier stages each coupled with a high pass filter are used, followed by a two stage low pass filter.

6. REFERENCES

(1) Quadruple Suspension Design for Advanced LIGO P020001-A-R

N A Robertson, G Cagnoli, D R M Crooks, E Elliffe, J E Faller, P Fritschel, S Goßler, A Grant, A Heptonstall, J Hough, H Lück, R Mittleman, M Perreure-Lloyd, M V Plissi, S Rowan, D H Shoemaker, P H Sneddon, K A Strain, C I Torrie, H Ward, P Willems