

- ① REFERENCED DOCUMENTATION:
 1.1 LIGO-E1100109, HAM SUS CONTROLS ARRANGEMENT.
 1.2 LIGO-D1101493, OSEM ORIENTATION.
 1.3 LIGO-D1101463, SYSTEM CABLING DIAGRAM.
 1.4 LIGO-D1002424, VIBRATION ABSORBER ORIENTATION.
 1.5 LIGO-E1100411, CABLE CLAMP TORQUE.
 1.6 LIGO-D1101296, HAM ISI HOLE TAB.

2. SEE SHEETS 4, 5, 6, 7, AND 8 FOR CABLE ROUTE DETAILS.

PR2

INSTALL CONFIGURATION (i.e.: IN CHAMBER - DOORS CLOSED)

REV.	DATE	DCN #	DRAWING TREE #
v1	25 APR 2012	-	-
v2	01 AUG 2012	E1200728-x0	-
-	-	-	-

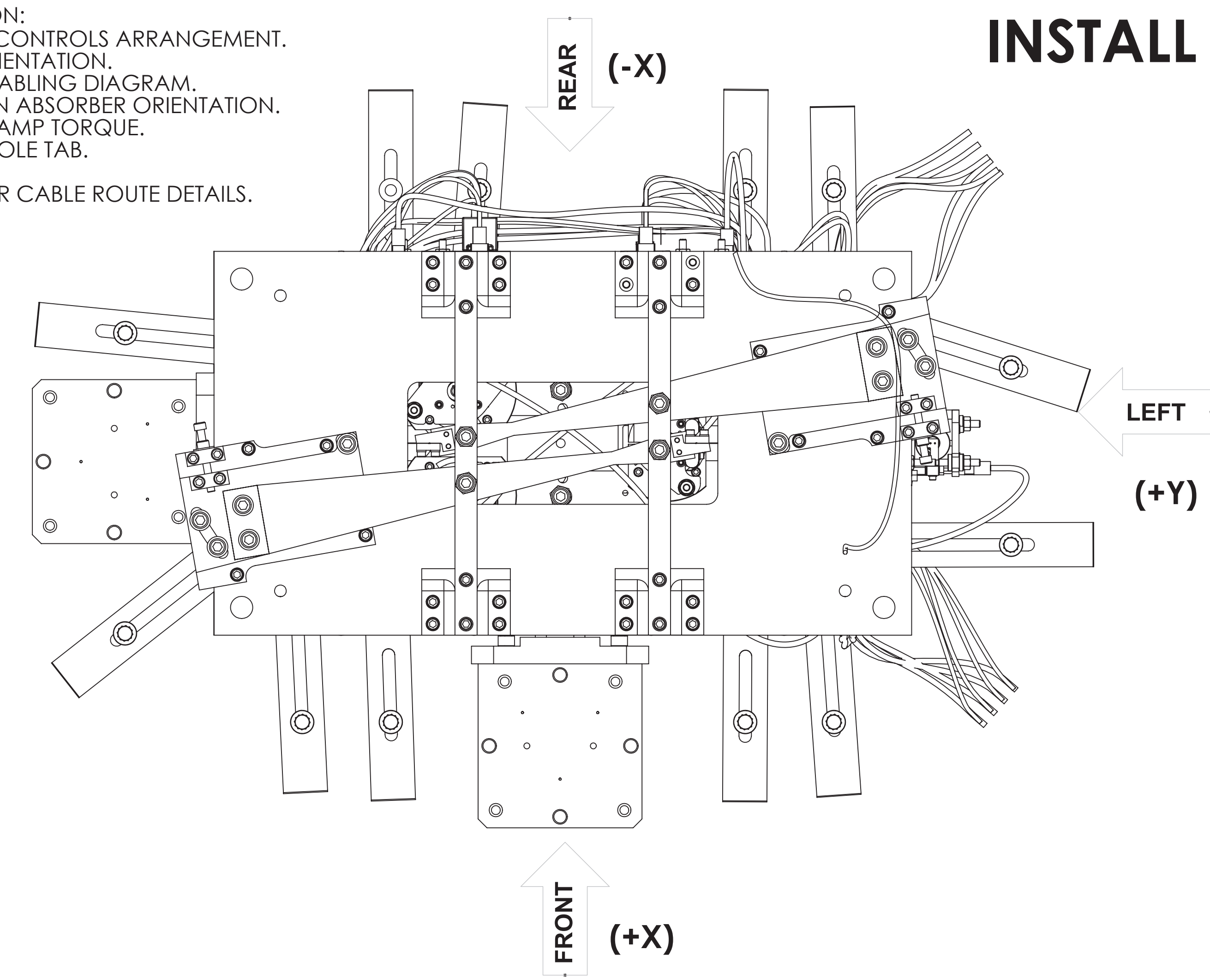
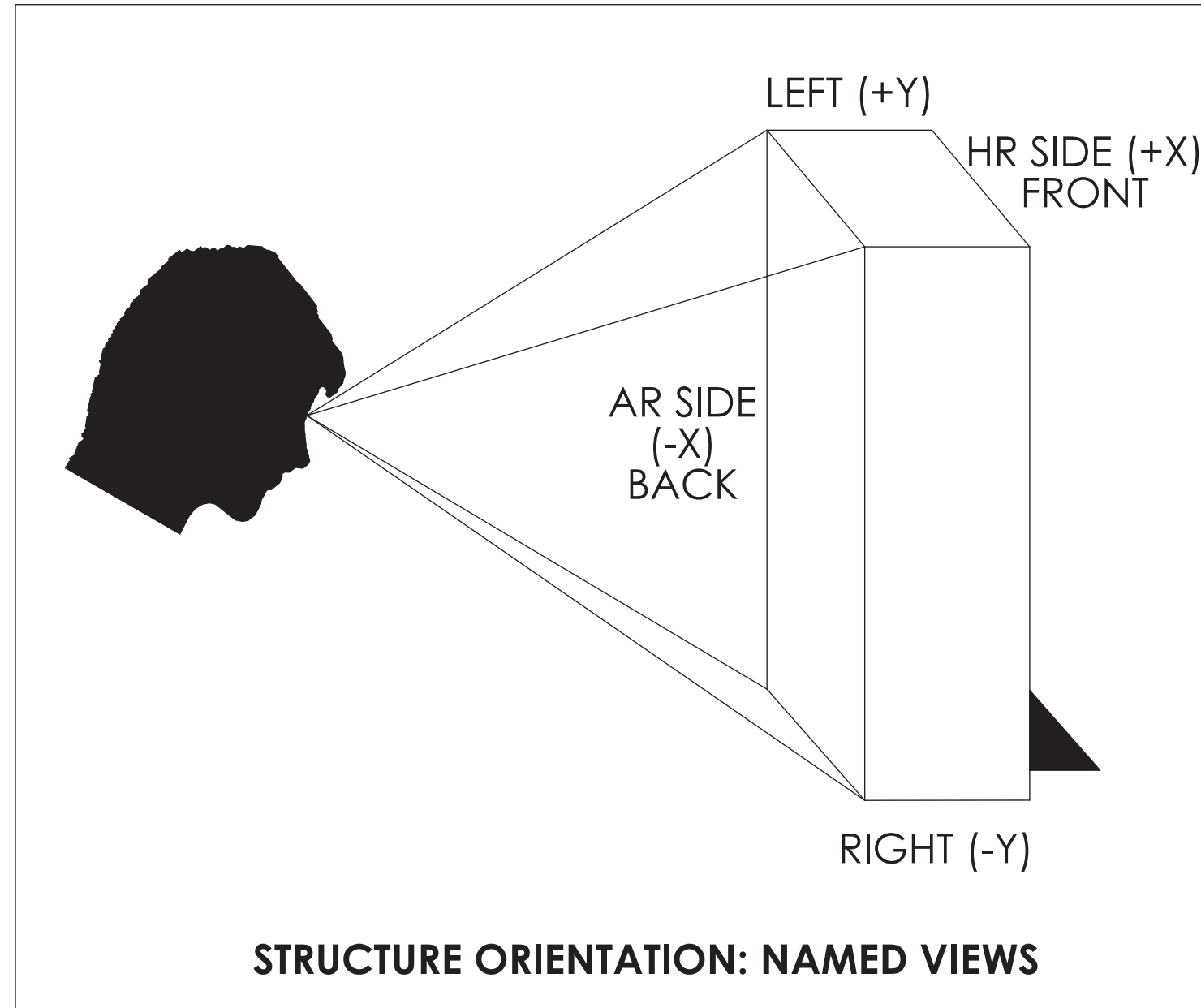
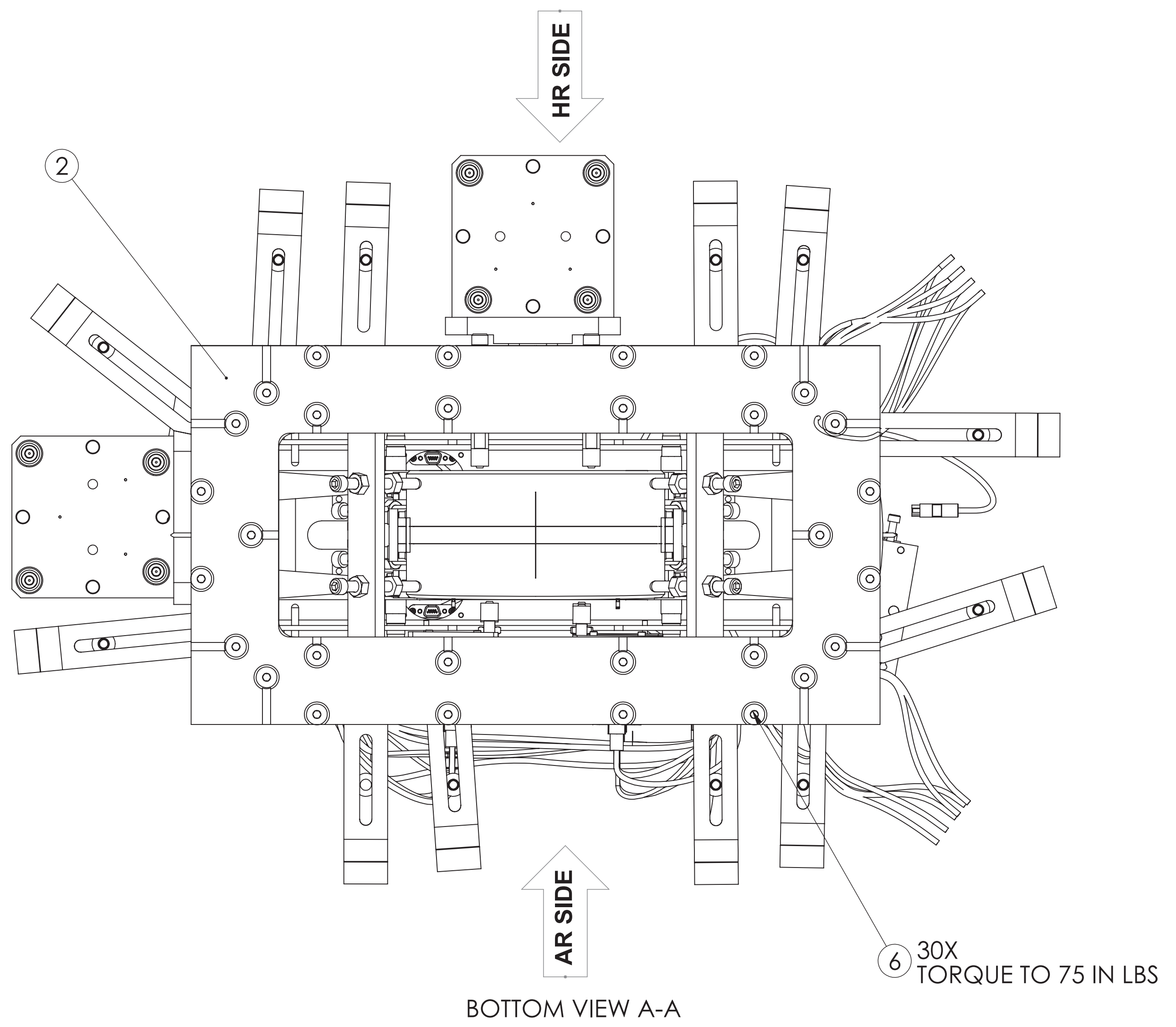
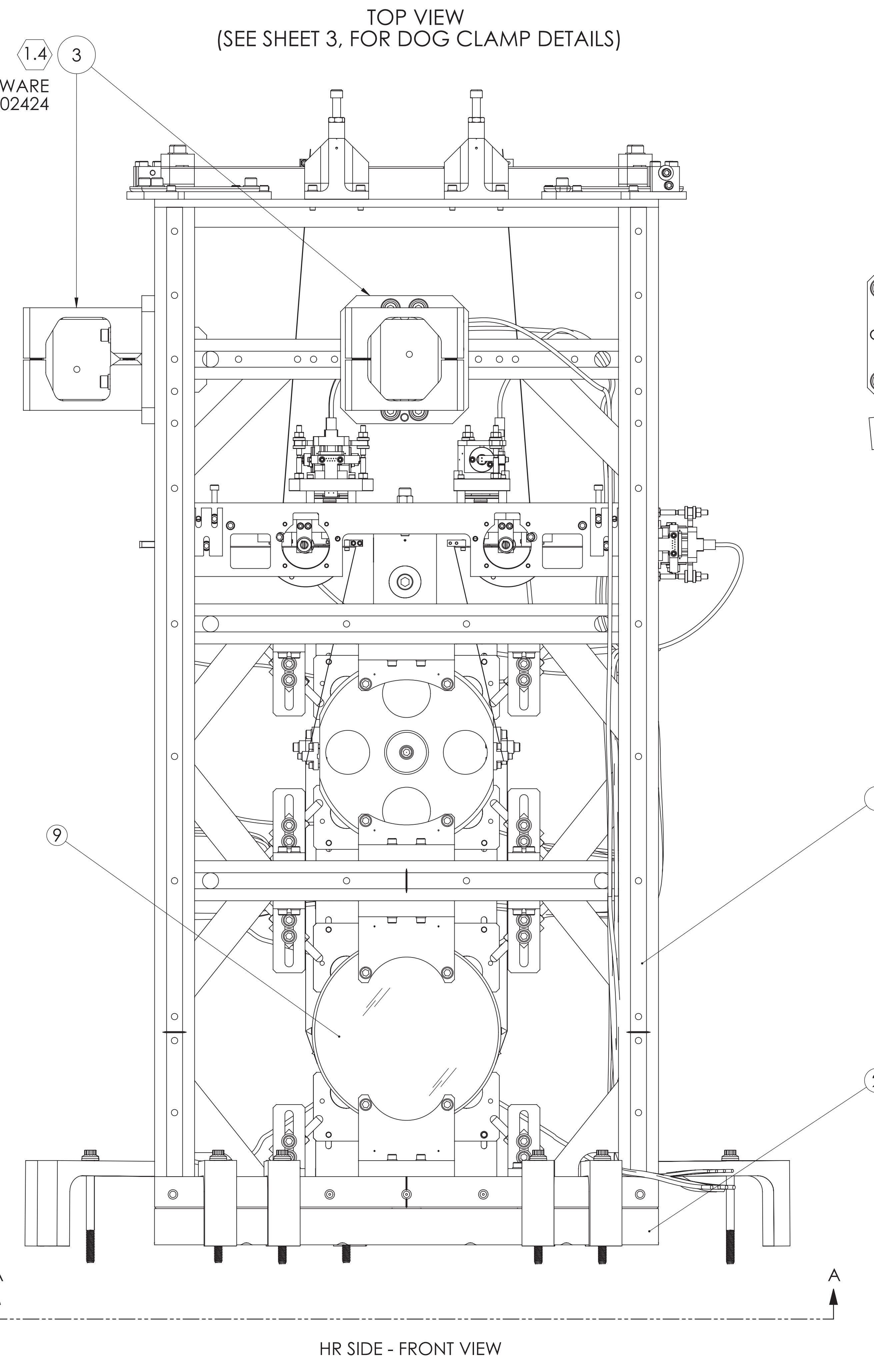

TABLE 1: HAM3-H1 PR2 CABLING SPECIFICATIONS, FROM/TO DES.

ROUTE NO.	FROM OSEM POSITION	TO CB FLOOR DES.	QP LEG DES.	CABLE PART NO.	NOM. CABLE LENGTH (IN)
1	M3-UL (S)	CB-2 (SECOND)	A	D1000234	60
	M3-LL (N)		B		
	M3-UR (N)		C		
	M3-LR (S)		D		
2	M2-UL (S)	CB-1 (SECOND)	A	D1000234	66
	M2-LL (N)		B		
	M2-UR (N)		C		
	M2-LR (S)		D		
3	M1-T3 (N)	CB-1 (FIRST)	A	D1000234	66
	M1-LF (N)		B		
	M1-RT (S)		C		
	M1-SD (S)		D		
4	M1-T1 (S)	CB-2 (FIRST)	C	D1000234	96
	M1-T2 (S)		D		

NOTE : ROUTE NO. 4 IS A SHARED CABLE. SEE D0901099 FOR QP LEGS 'A' AND 'B' ROUTING



LOCAL COORDINATES - REFERENCE

Xmm	Ymm	Zmm	YAW °
249.3	-530.4	-83.2	.46°

REFER TO DRAWING D1101252 FOR HAM3-H1 INSTALLATION PLATE LAYOUT

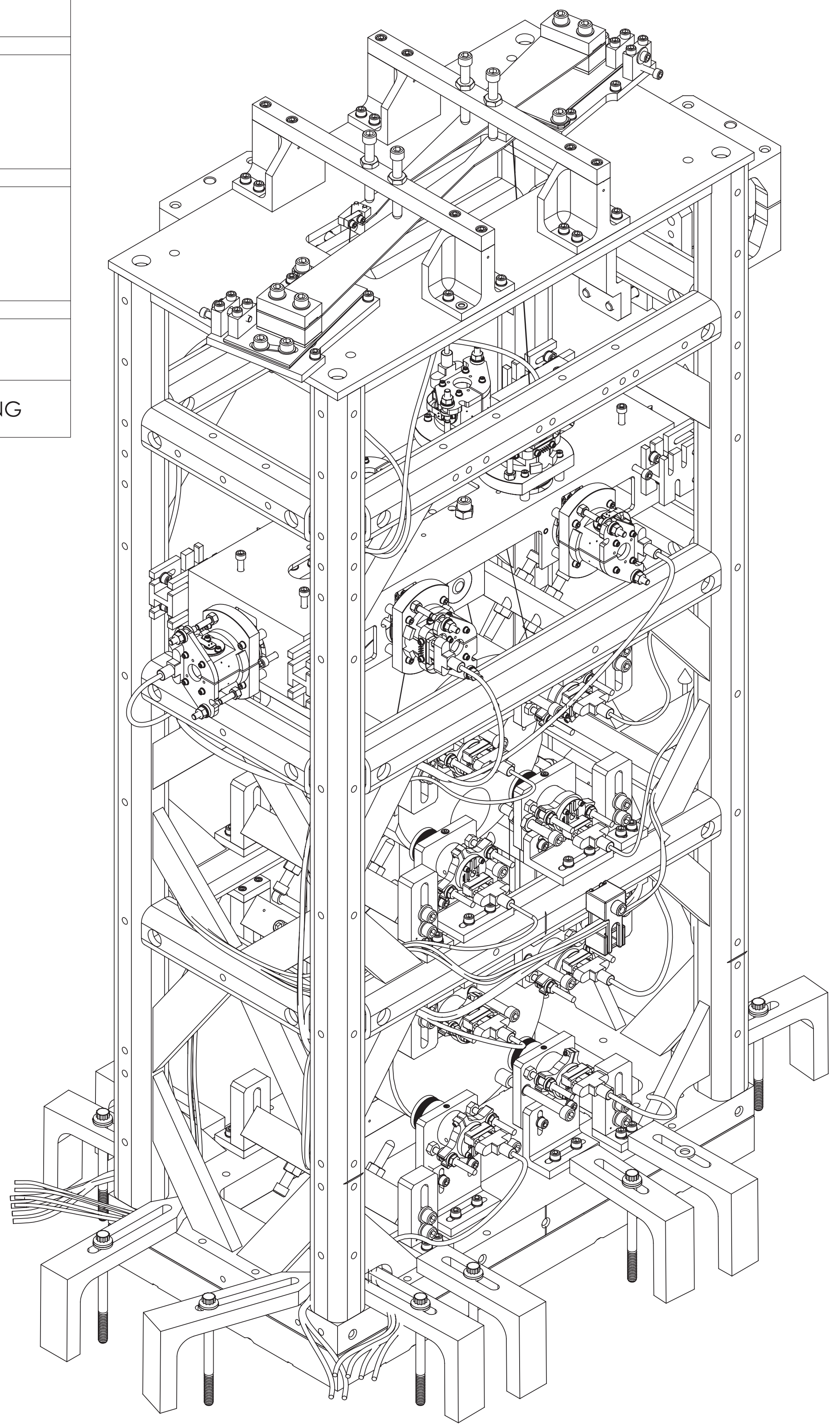

ITEM NO.	PART NUMBER	DESCRIPTION	MATERIAL	QTY
10	D0902462	CLAMP ASSY., UHV COMPATIBLE	N/A	1
9	D1101378	PR2 H1 OPTICS ASSEMBLY	N/A	1
8	D1100785-530	WASHER, FLAT, .25 X .530 O.D.	NITRONIC 60	12
7	2AL3.25-12SL	1/4-20 X 3.25 12PT BOLT	450 SSSL	12
6	FA-2024-NA	.25-20 X 1.5 FHSC SCREW UC COMPONENTS FA-2024-NA	18-8 SSSL	30
5	D1100641-09	AdvLIGO HAM Optics Table Dog Clamp Chamfered End 2.2L	304 SSSL	7
4	D1001376-08	AdvLIGO HAM Optics Table Dog Clamp 2.20M	304 SSSL	5
3	D1002424	VIBRATION ABSORBER ASSEMBLY	N/A	2
2	D1100038	HSTS SUS STRUCTURE SPACER 28.7MM	6061-T6 Al	1
1	D020700	HSTS OVERALL ASSEMBLY	N/A	1

NOTES AND TOLERANCES: (UNLESS OTHERWISE SPECIFIED)

MATERIAL	N/A	FINISH	N/A μinch
----------	-----	--------	-----------

SYSTEM: ADVANCED LIGO SUB-SYSTEM: SUS PART NAME: AdvLIGO SUS HAM3-H1, XYZ Local CS for HSTS (PR2) Sub-Assy.
 DRAFTER: E.SANCHEZ DATE: 25 APR 2012 SIZE: E DWG. NO.: D0901098 REV.: v2
 CHECKER: E.SANCHEZ DATE: 25 APR 2012
 APPROVAL: SEE DCC SEE DCC SCALE: 1:2 PROJECTION: SHEET 1 OF 9

PR2

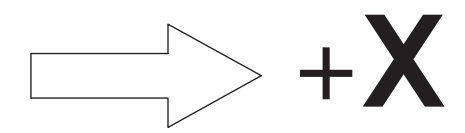
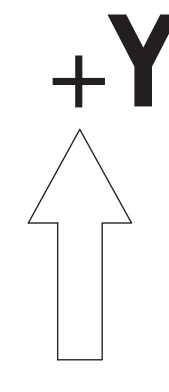

HR SIDE

AR SIDE

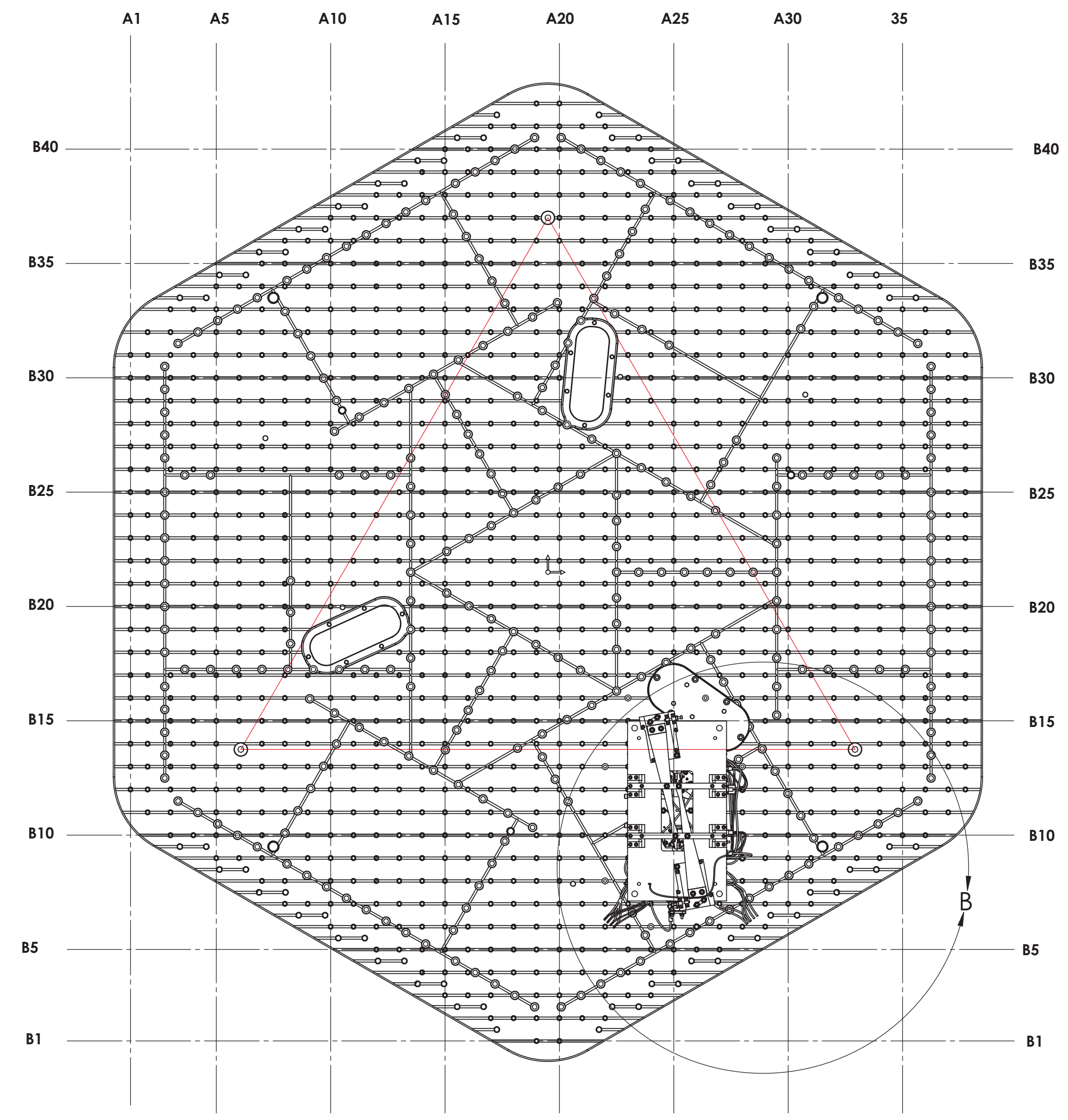

TOP VIEW 1.6
REF. TRIANGLE: SEE D1000125 FOR
ISI NAMING AND ORIENTATION CONVENTION

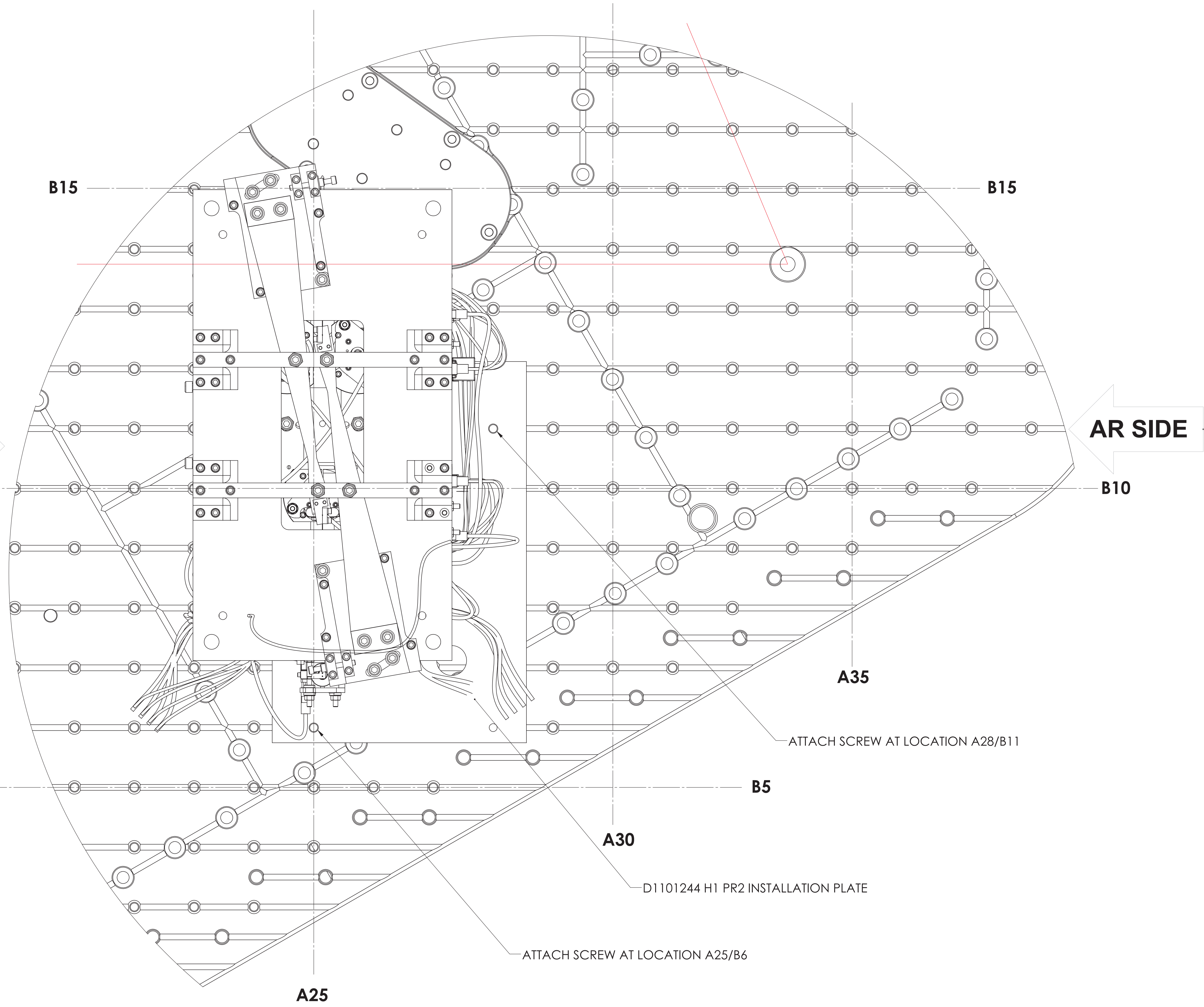

DETAIL B
SCALE 1 : 1.5

TOP VIEW SHOWING INSTALLATION PLATE LOCATION 1.6
OPTICAL TABLE SHOWN FOR STRUCTURE LOCATION AND ORIENTATION,
DOG CLAMPS VIBRATION ABSORBERS AND HARDWARE REMOVED FOR CLARITY

ALIGNMENT PLATE INSTALLATION / LOCATION

PR2

+Y

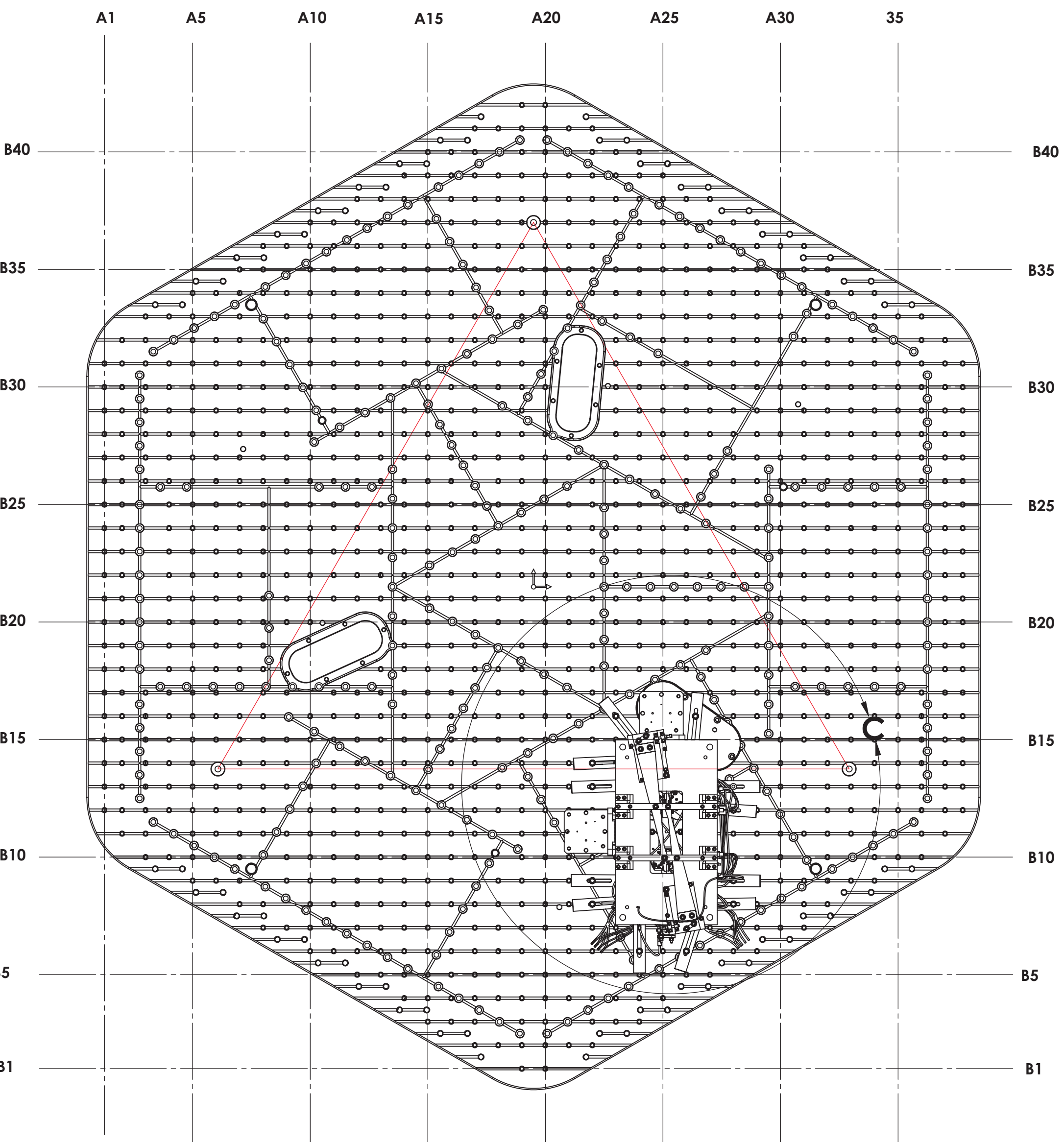

TOP VIEW 1.6

REF. TRIANGLE: SEE G1000125 FOR ISI NAMING AND ORIENTATION CONVENTION

③ SCREW LOCATION A22/B14

③ SCREW LOCATION A22/B13

HR SIDE

③ SCREW LOCATION A22/B9

③ SCREW LOCATION A22/B8

ITEM NO.	PART NUMBER	DESCRIPTION	MATERIAL	QTY
8	D1100785-530	WASHER, FLAT, .25 X .530 O.D.	NITRONIC 60	12
7	2AL3.25-12SL	1/4-20 X 3.25 12PT BOLT	450 SSSL	12
5	D1100641-09	AdvLIGO HAM Optics Table Dog Clamp Chamfered End 2.2L	304 SSSL	7
4	D1001376-08	AdvLIGO HAM Optics Table Dog Clamp 2.20M	304 SSSL	5

PARTIAL BOM. SEE SHEET 1 FOR COMPLETE PARTS LIST

③ SCREW LOCATION ON A23/B16

③ SCREW LOCATION ON SPRING HATCH NEAR A26/B16

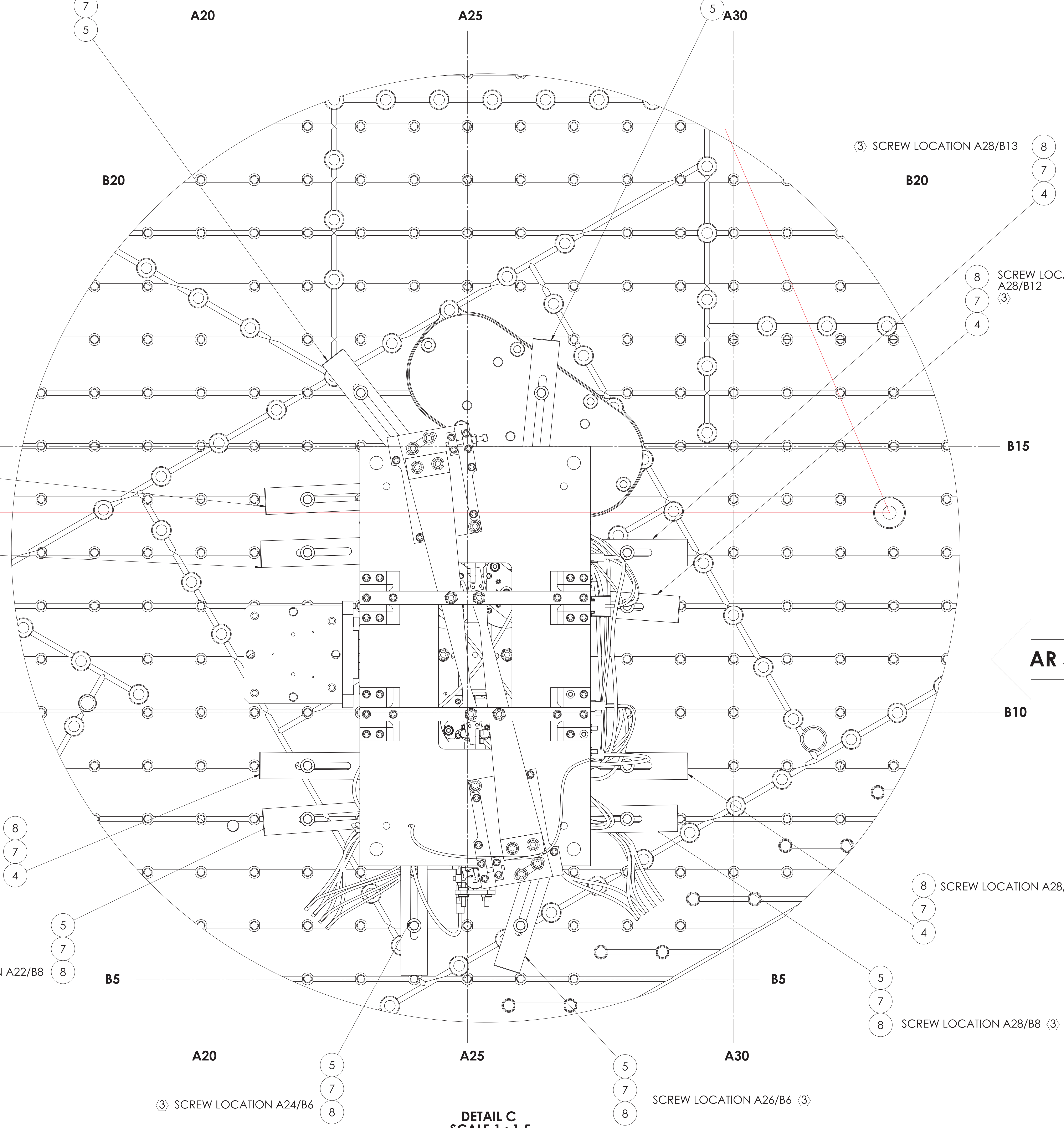

③ SCREW LOCATION A24/B6

SCREW LOCATION A26/B6 ③

③ SCREW LOCATION A28/B13

③ SCREW LOCATION A28/B12

③ SCREW LOCATION A28/B9

③ SCREW LOCATION A28/B8

AR SIDE

DETAIL C SCALE 1:1.5

TOP VIEW 1.6

OPTICAL TABLE SHOWN FOR STRUCTURE AND DOG CLAMP LOCATIONS AND ORIENTATION

DOG CLAMPS IDENTIFICATION / INSTALLATION

③ TORQUE TO 100 IN LBS (USE STANDARD 12 PT SOCKET)

LIGO CALIFORNIA INSTITUTE OF TECHNOLOGY
 MASSACHUSETTS INSTITUTE OF TECHNOLOGY
 SIZE DWG. NO. **D0901098** REV. **v2**
 SCALE: 1:4 PROJECTION: SHEET 3 OF 9

PR2

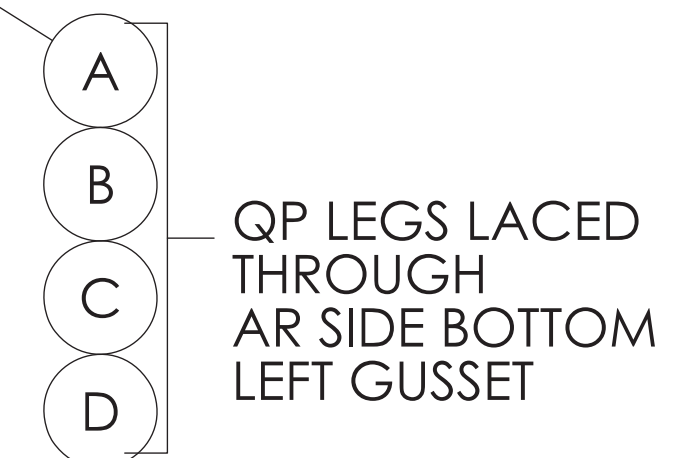
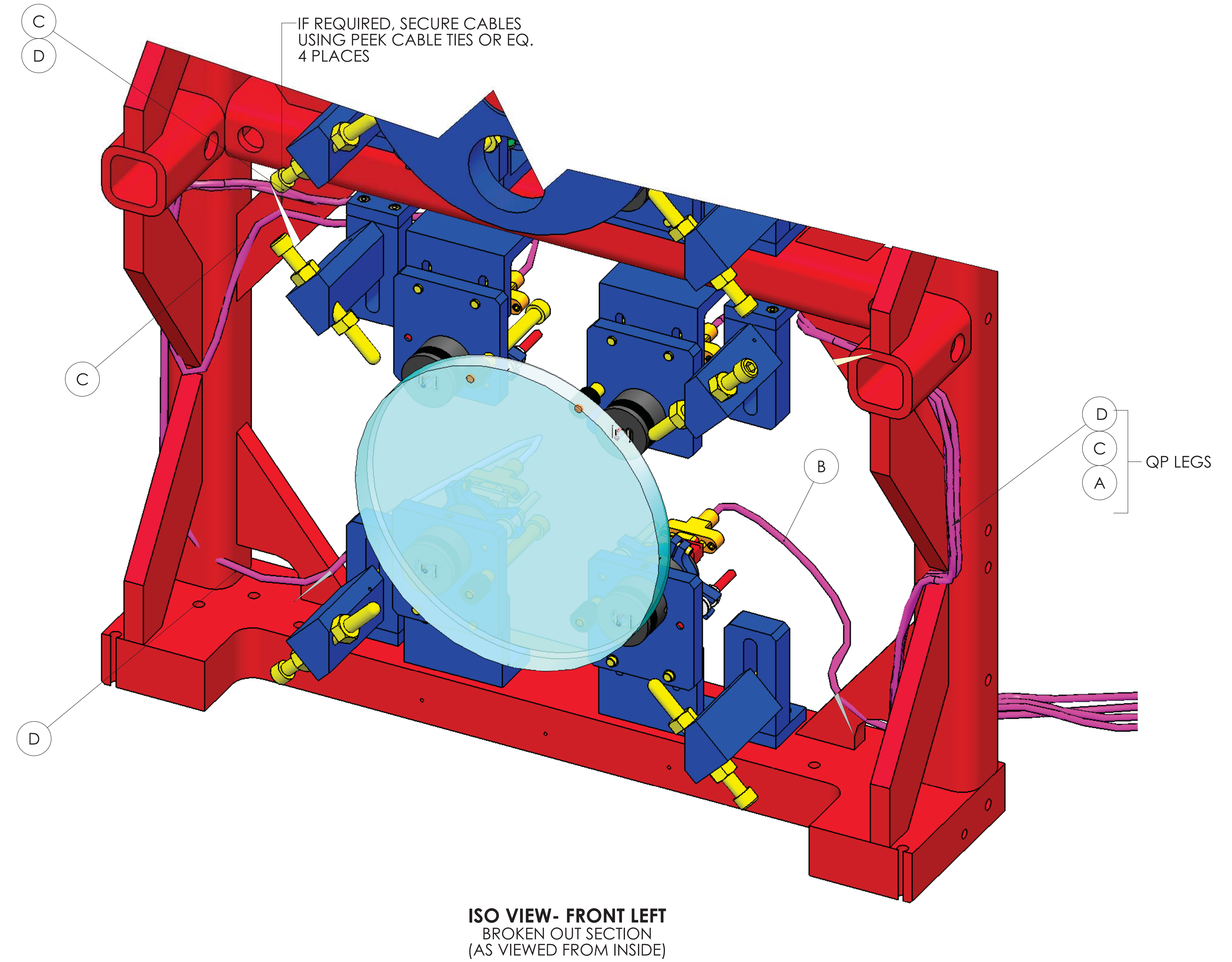
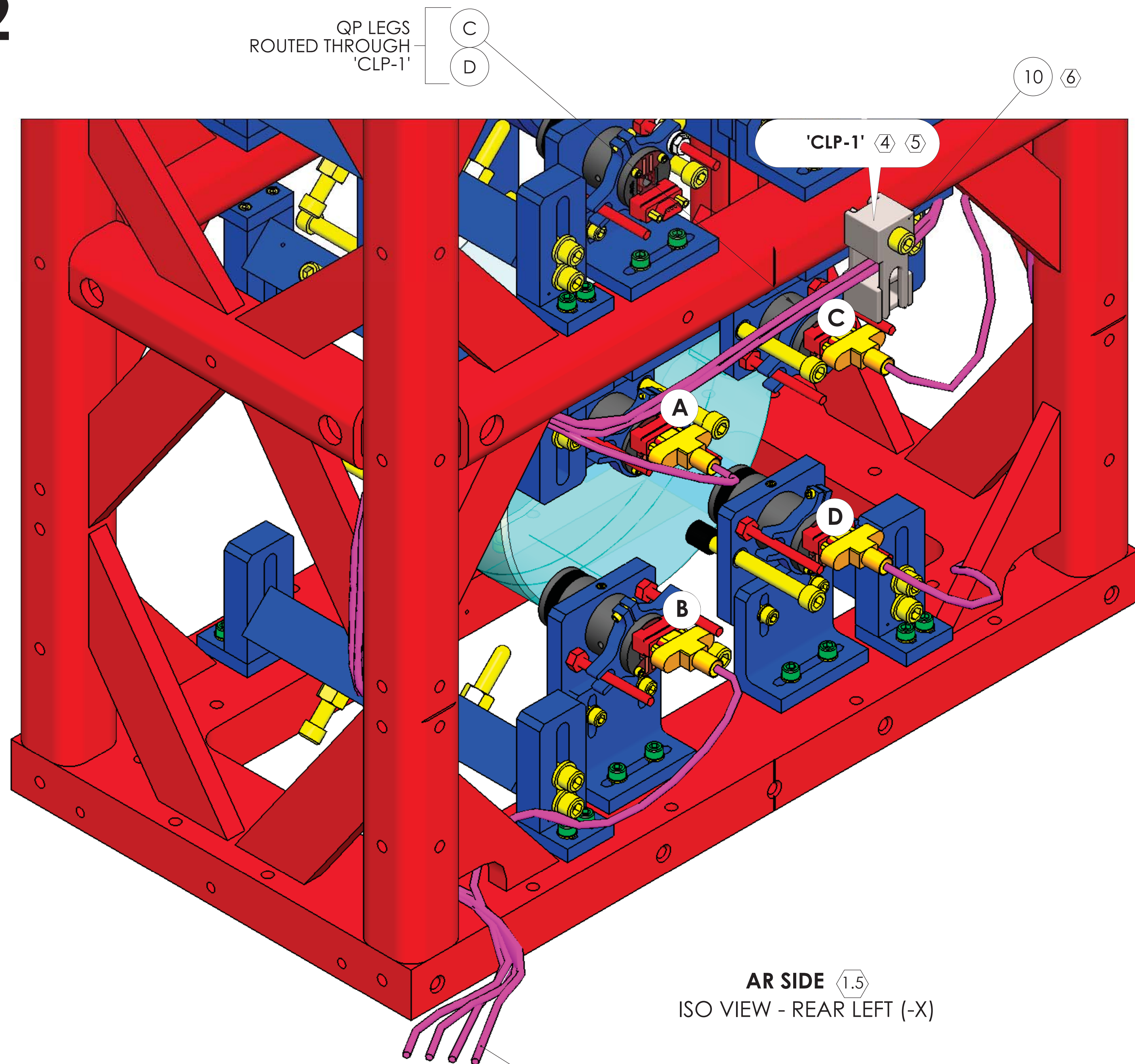

CABLE ROUTING:
ROUTE ALL CABLES IN ACCORDANCE WITH LIGO-T1200203 AND T1200318. CABLE ROUTES DEPICTED IN THIS DOCUMENT ARE NOT MANDATORY, BUT RATHER A CONSIDERED ROUTE AIMED TO CLEAR LASER BEAM PATHS. ALTERNATE ROUTES FOR PROBLEMATIC AREAS ARE ACCEPTABLE, BUT SHOULD BE HANDLED IN A CASE BY CASE SITUATION. IT IS IMPERATIVE TO CONSIDER THE LENGTH OF THE CABLE, THE LOCATION OF MATING CABLE BRACKET, AND LASER BEAM PATH PRIOR TO ROUTING / LACING VIA A NEW PATH.

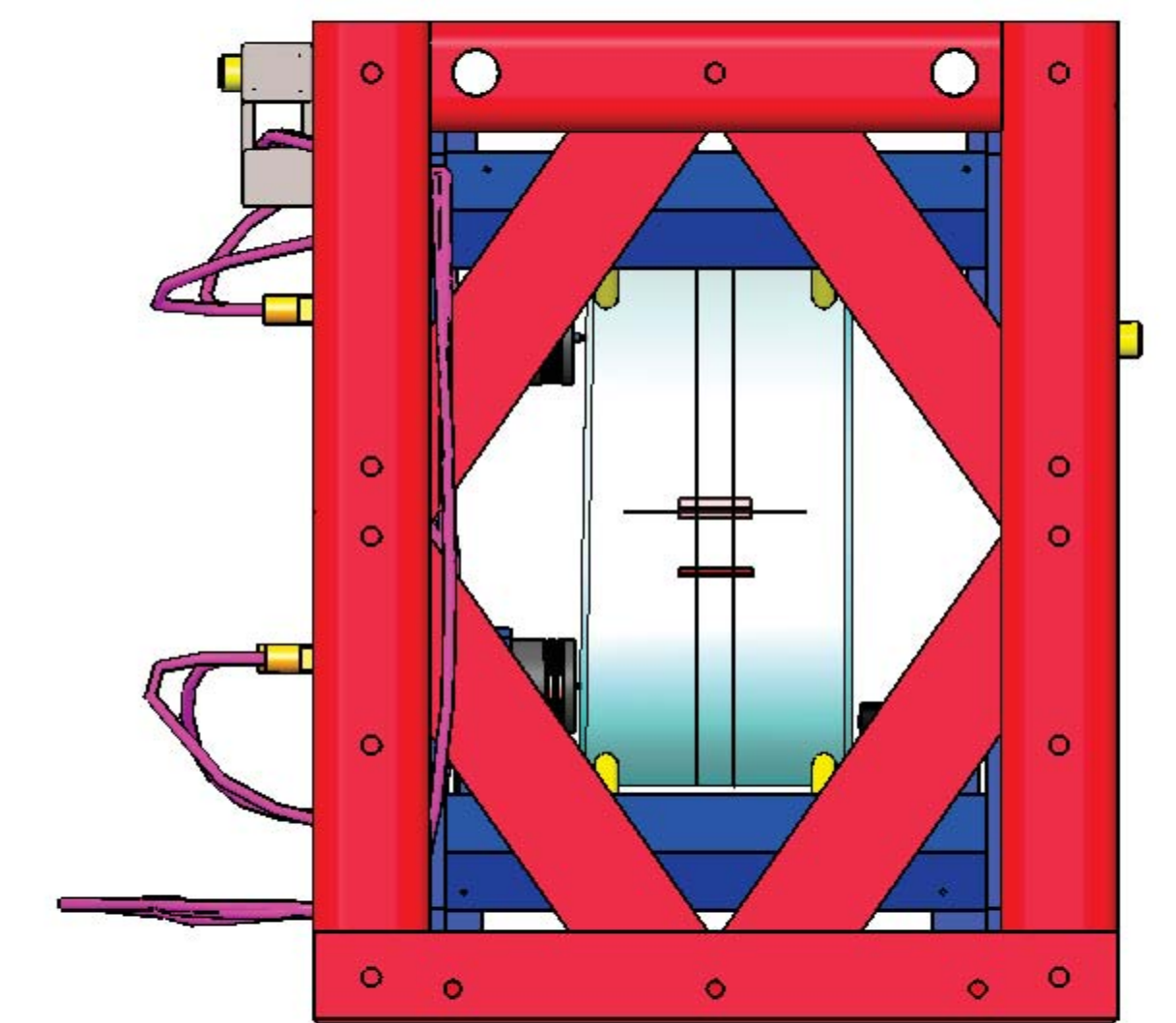
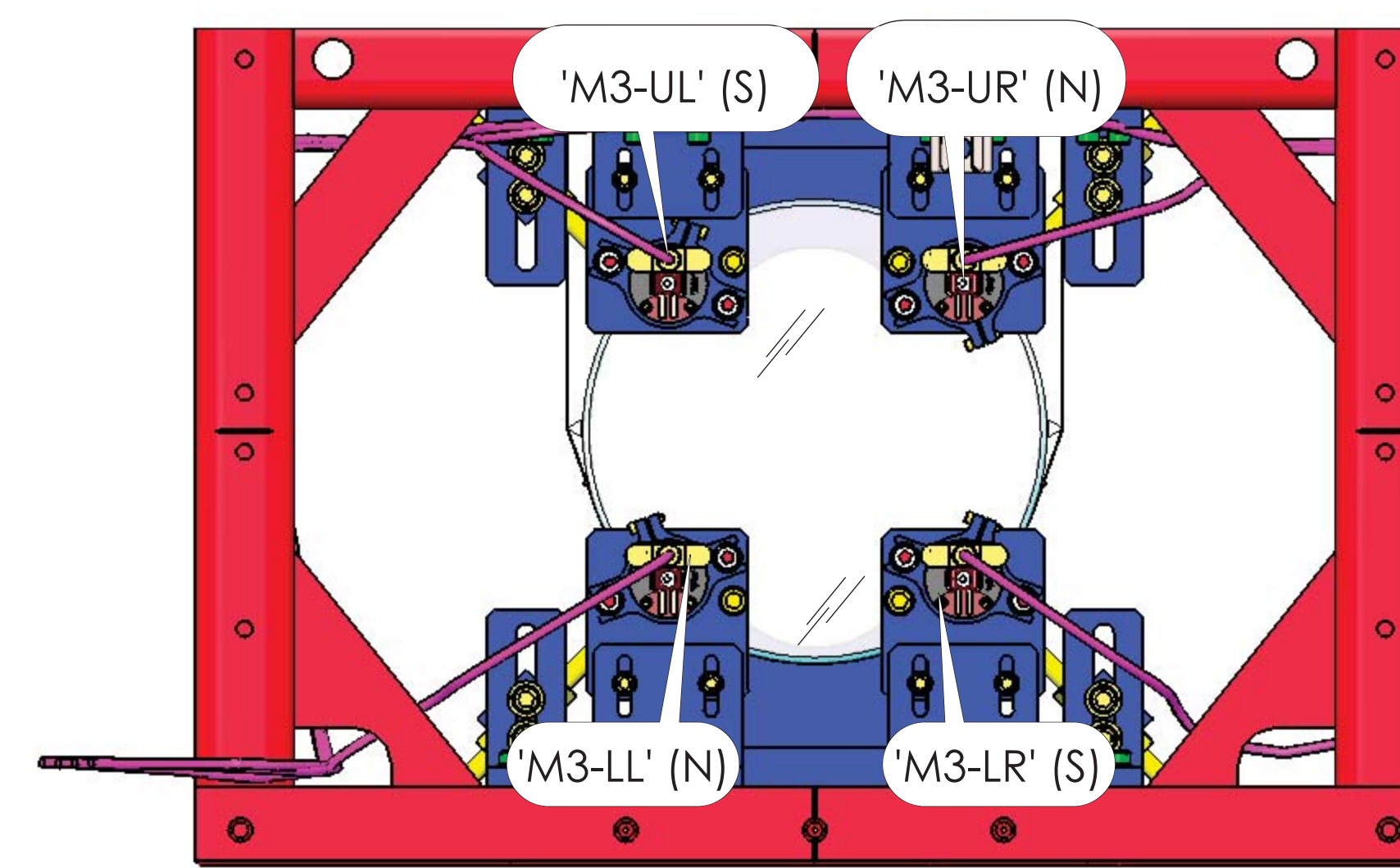
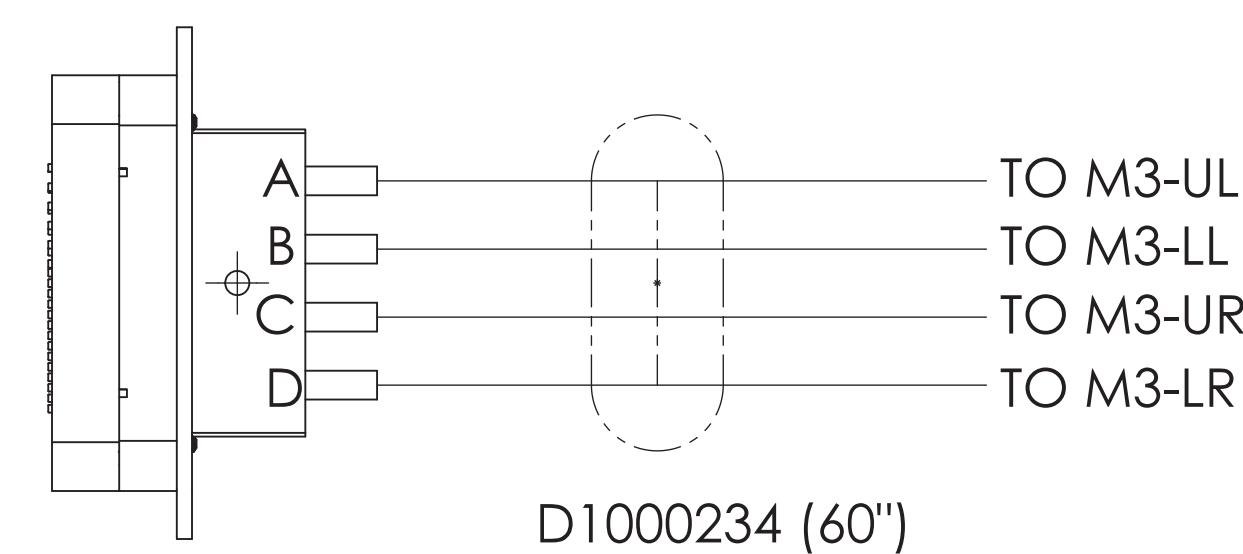
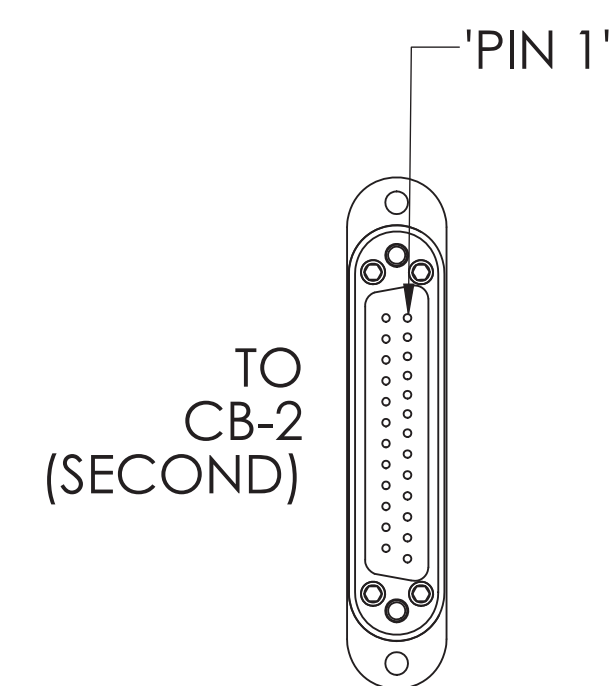
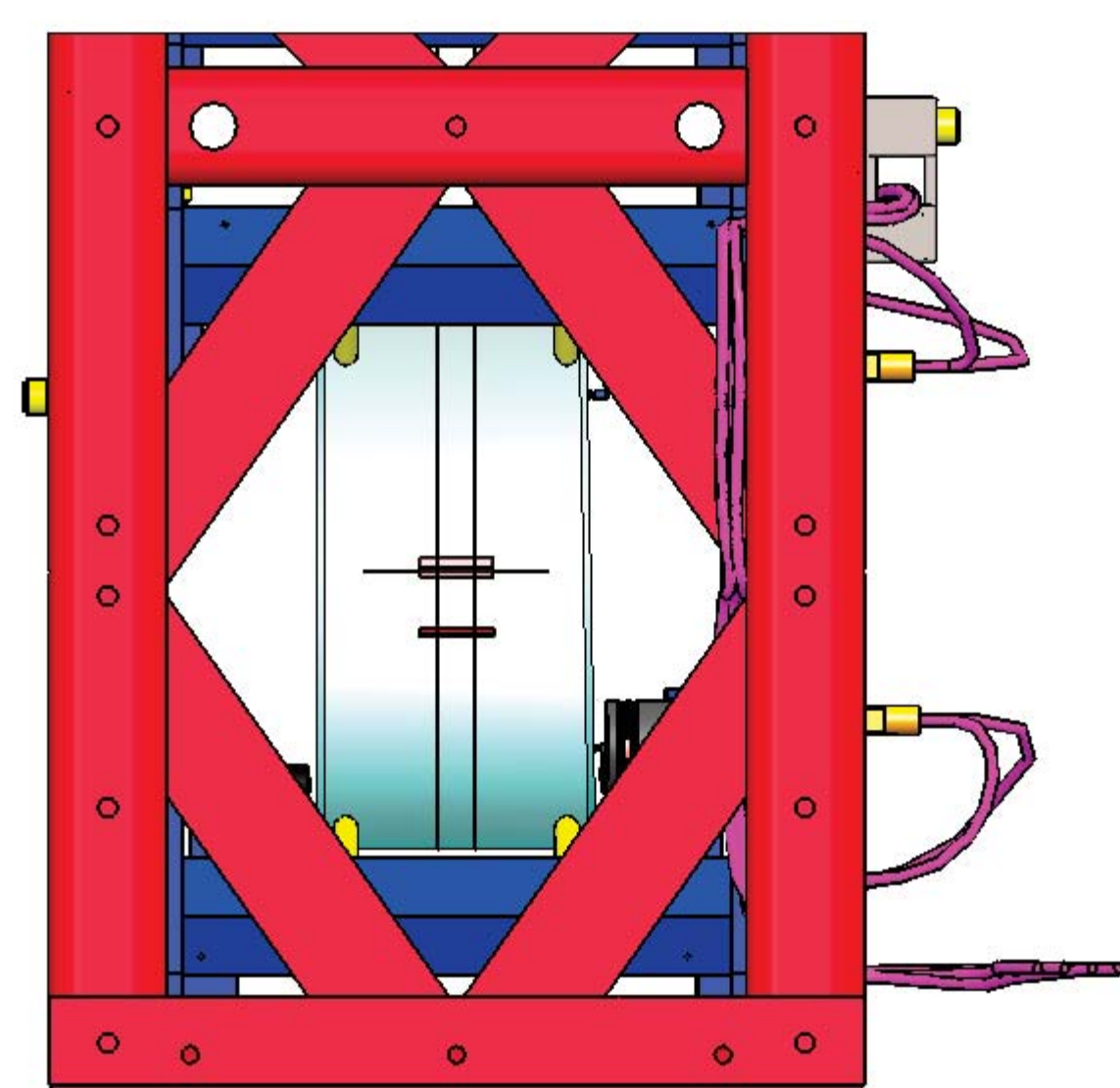

④ DO NOT CLAMP CABLES TIGHTLY. PROVIDE SUFFICIENT SPACE FOR THE CABLES TO RUN FREELY BETWEEN CLAMP JAWS.

⑤ SHORTING MAY OCCUR IN QP BOSEM & AOSEM TEFLON CABLES CLAMPED EXCESSIVELY TIGHT. THEREFORE, THE PEEK CLAMPS (i.e. 'CLP-1' AND CABLE TIES) SHOULD SERVE ONLY AS A GUIDE FOR THE CABLES TO REACH THEIR DESTINATION, AND SHOULD NOT CLAMP THE CABLES IN PLACE.

⑥ TORQUE TO APPROXIMATELY 20 IN/LBS.

ROUTE NO. 1
SEE LIGO-T1200318
FOR STEP BY STEP CABLING GUIDE

PR2

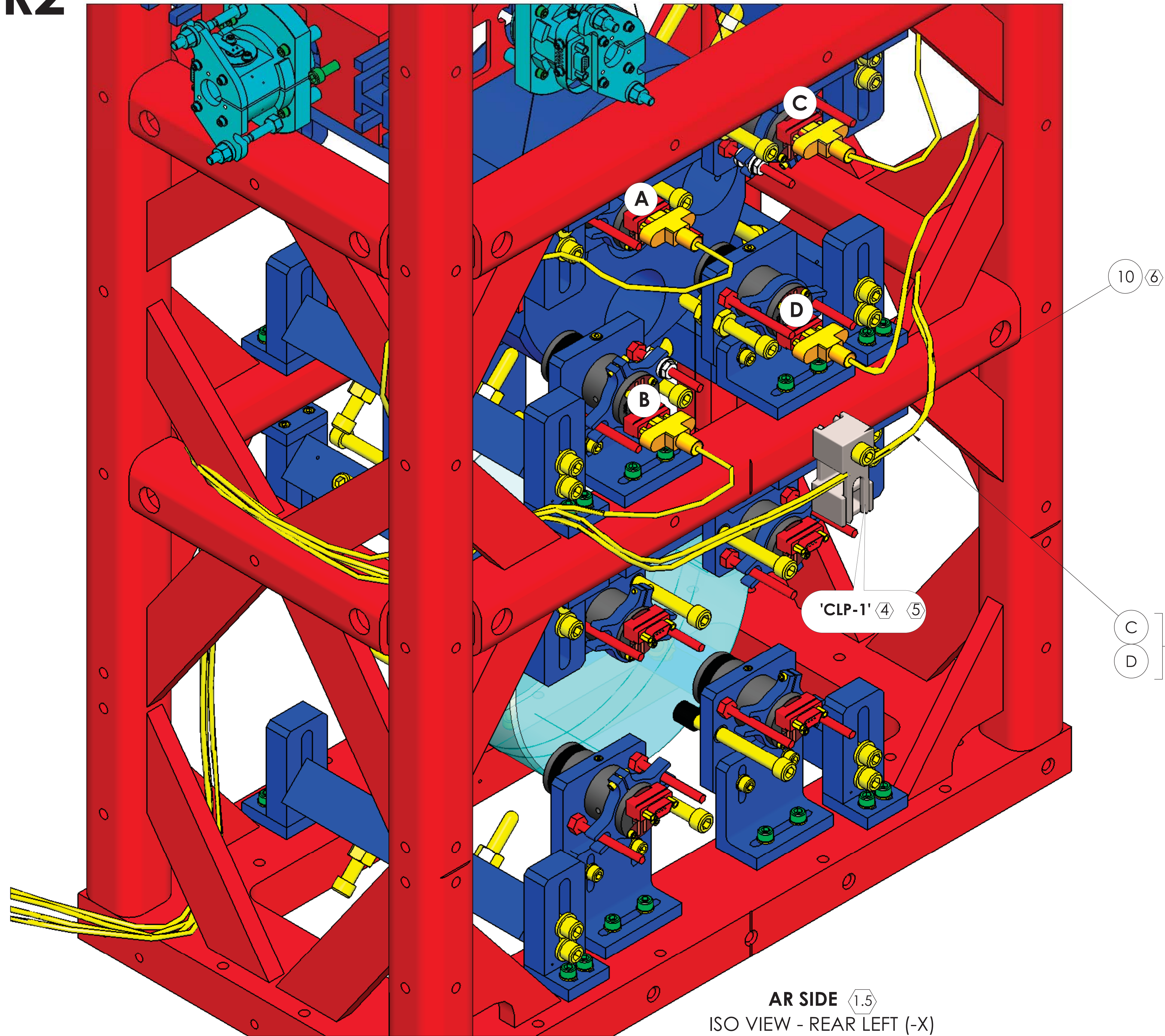

ISO VIEW - REAR LEFT (-X)

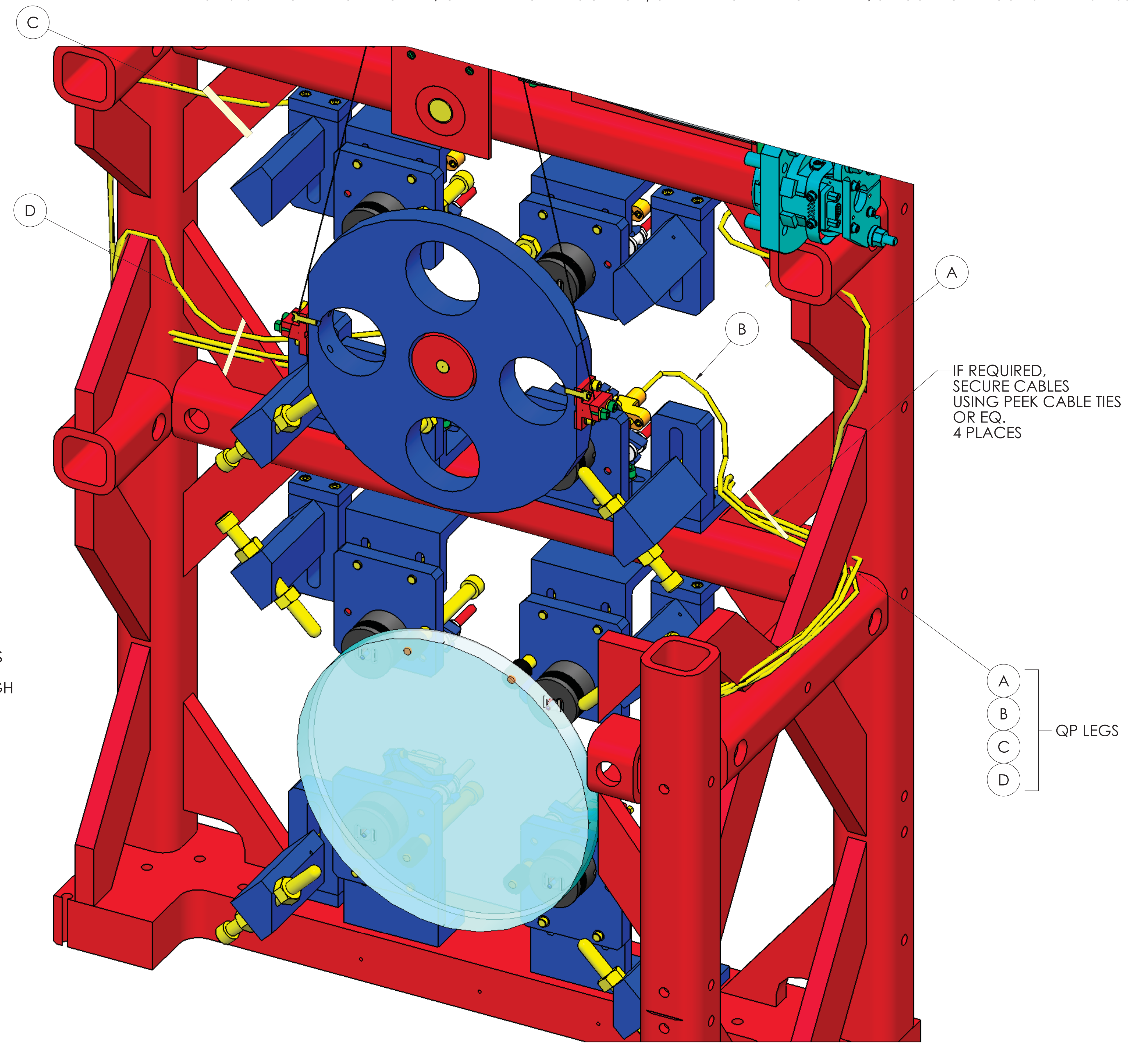

ISO VIEW - FRONT LEFT
BROKEN OUT SECTION
(AS VIEWED FROM INSIDE)

C } QP LEGS
D } ROUTED
THROUGH
'CLP-1'

A } QP LEGS
B }
C }
D }

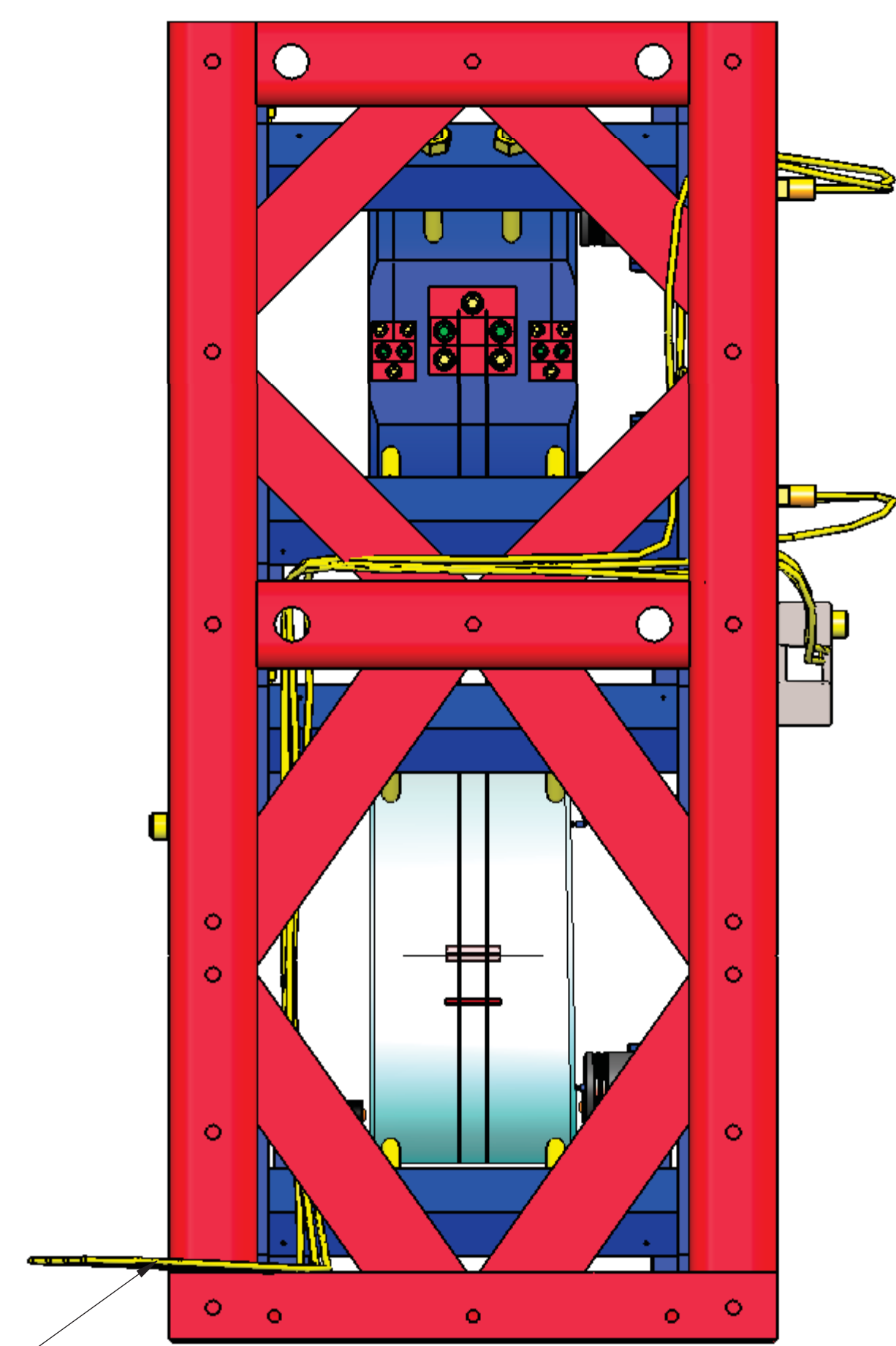

LEFT SIDE (+Y)



CABLE ROUTING:
ROUTE ALL CABLES IN ACCORDANCE WITH LIGO-T1200203 AND T1200318. CABLE ROUTES DEPICTED IN THIS DOCUMENT ARE NOT MANDATORY, BUT RATHER A CONSIDERED ROUTE AIMED TO CLEAR LASER BEAM PATHS. ALTERNATE ROUTES FOR PROBLEMATIC AREAS ARE ACCEPTABLE, BUT SHOULD BE HANDLED IN A CASE BY CASE SITUATION. IT IS IMPERATIVE TO CONSIDER THE LENGTH OF THE CABLE, THE LOCATION OF MATING CABLE BRACKET, AND LASER BEAM PATH PRIOR TO ROUTING / LACING VIA A NEW PATH.

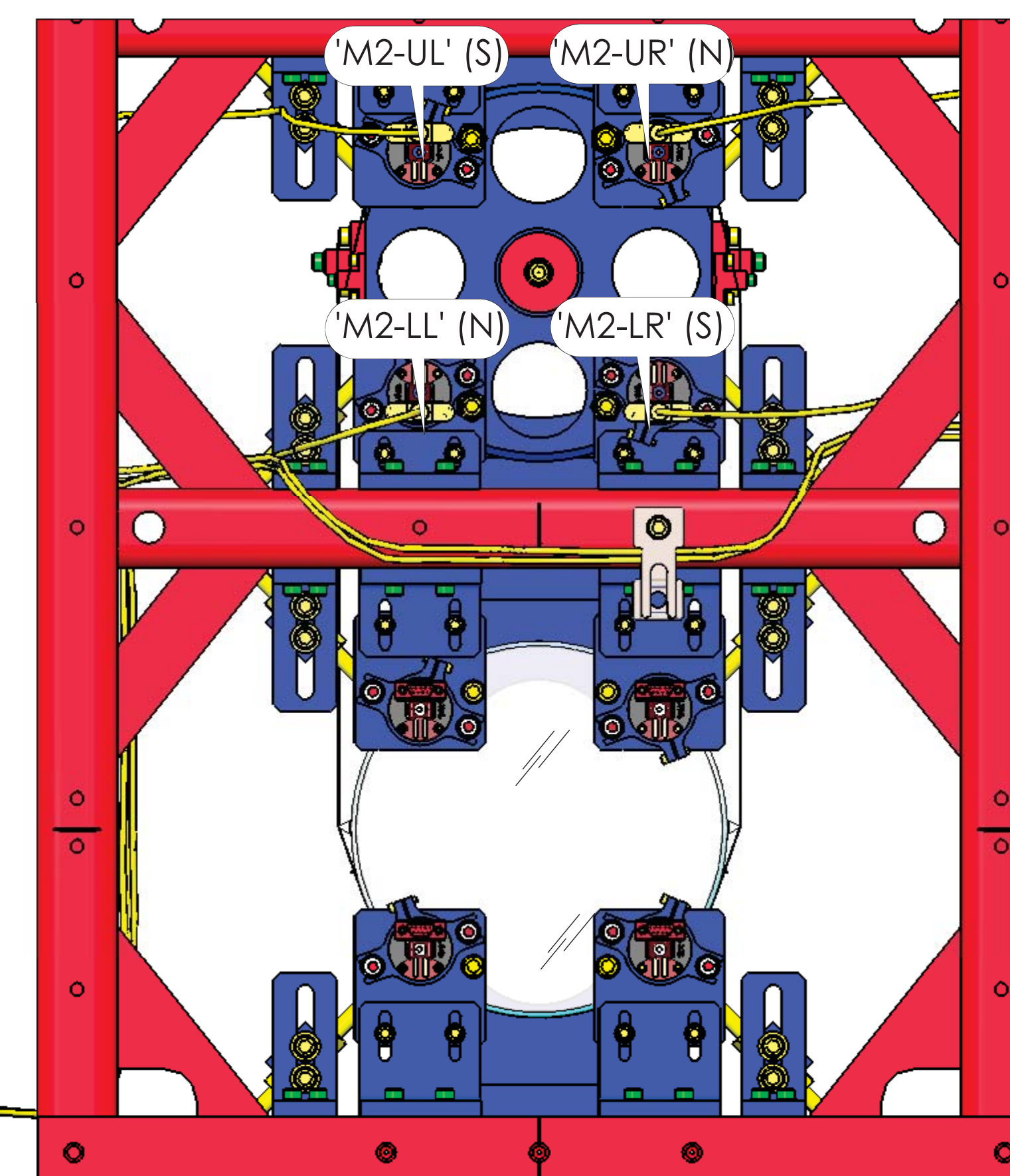
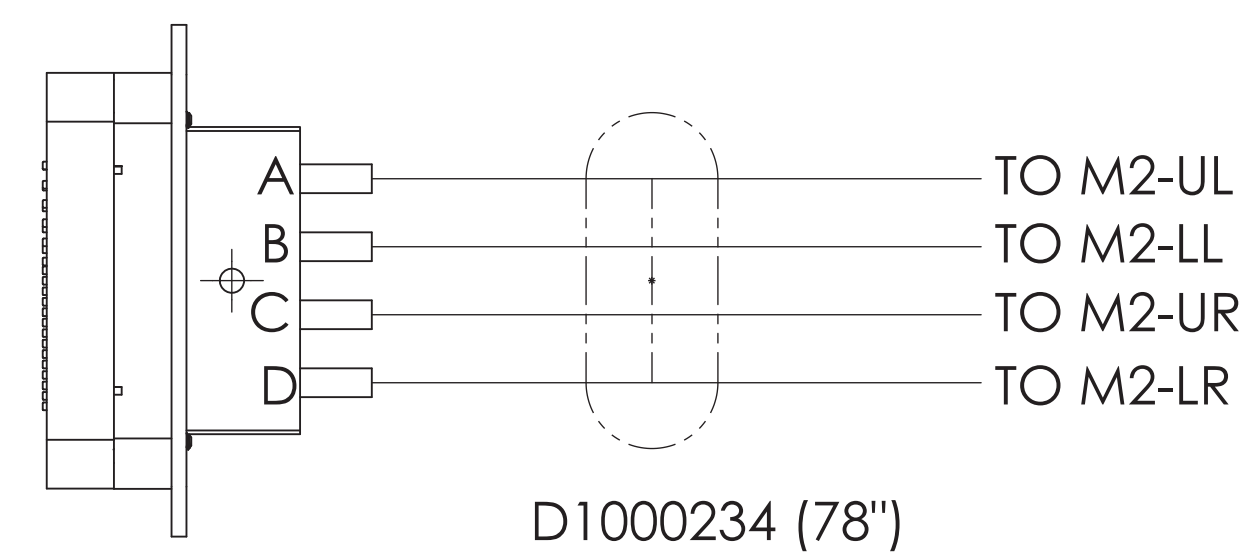
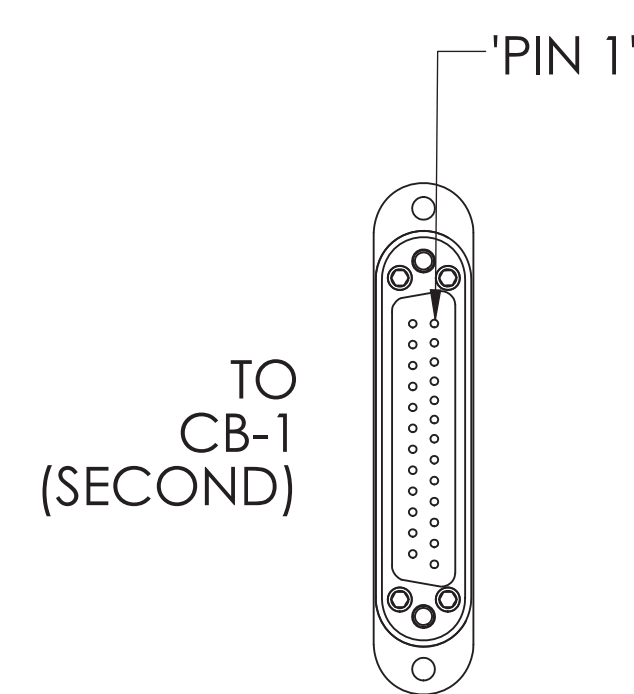

AR SIDE - REAR (-X) (1.1) (1.2)
(END CONNECTORS, NOT SHOWN FOR CLARITY)

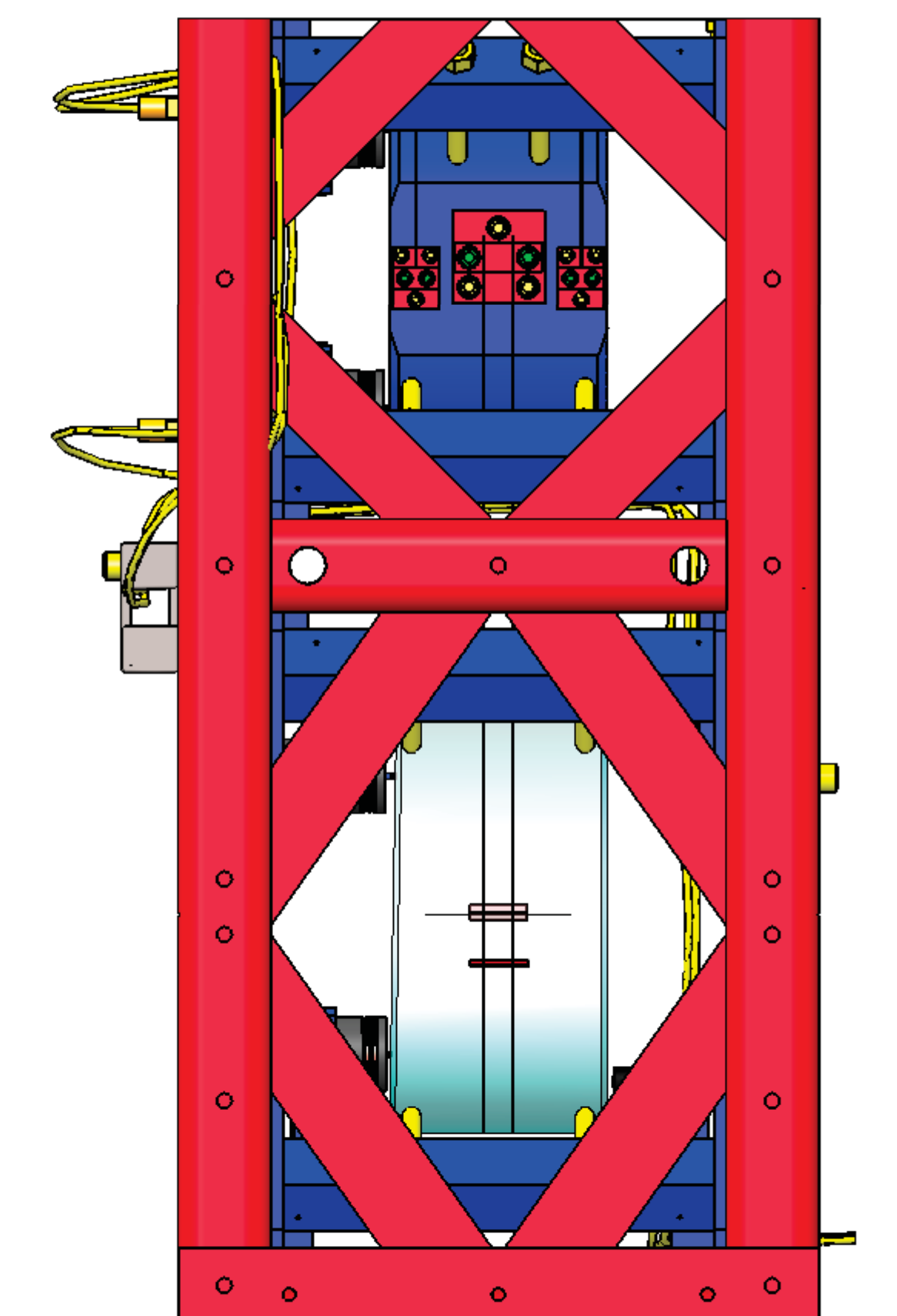

RIGHT SIDE (-Y)

A } QP LEGS LACED
B } THROUGH
C } LEFT SIDE BOTTOM
D } LEFT GUSSET

ROUTE NO. 2

SEE LIGO-T1200318
FOR STEP BY STEP CABLING GUIDE

PR2

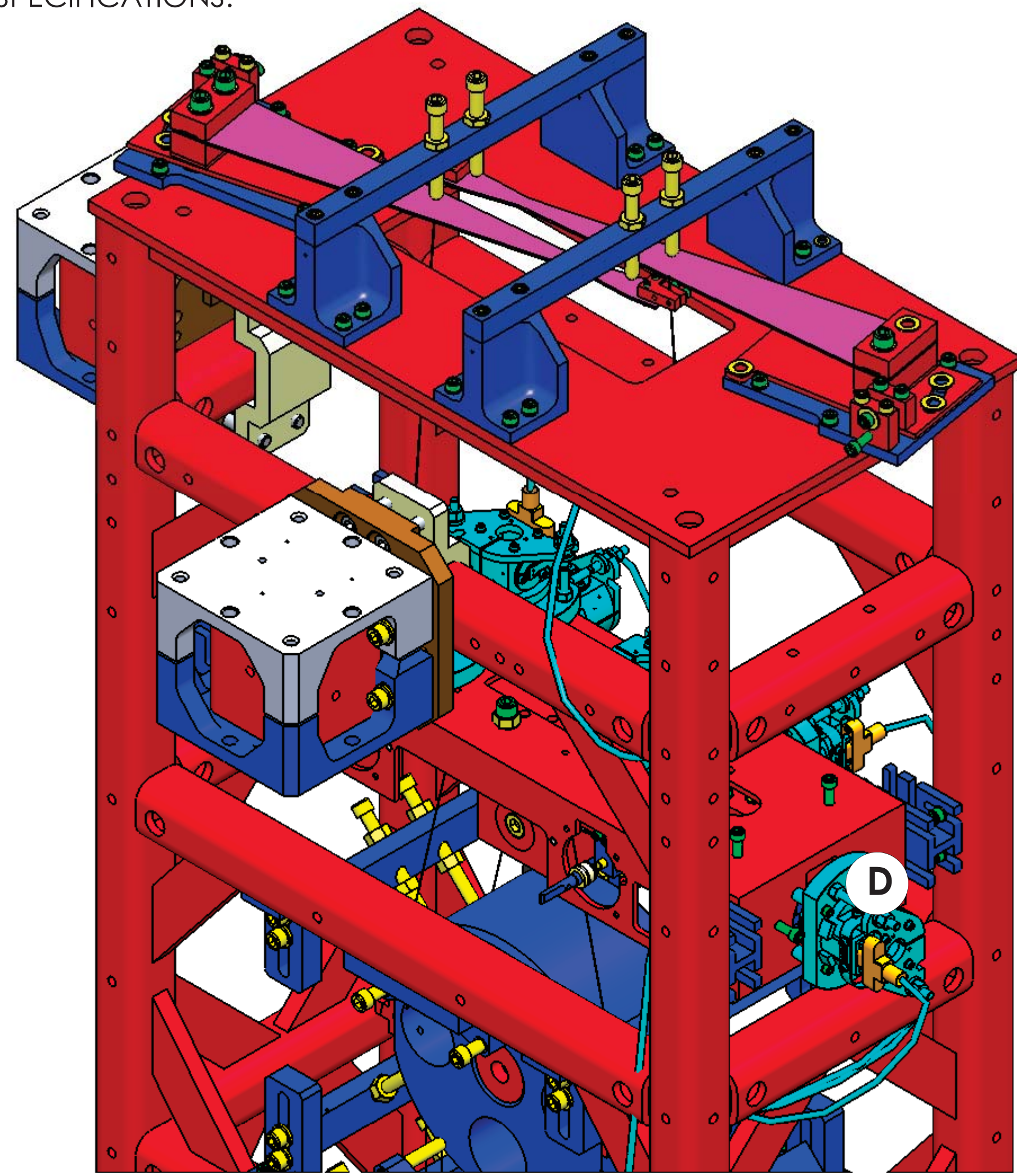

HR SIDE
ISO VIEW, FRONT - LEFT (+X)

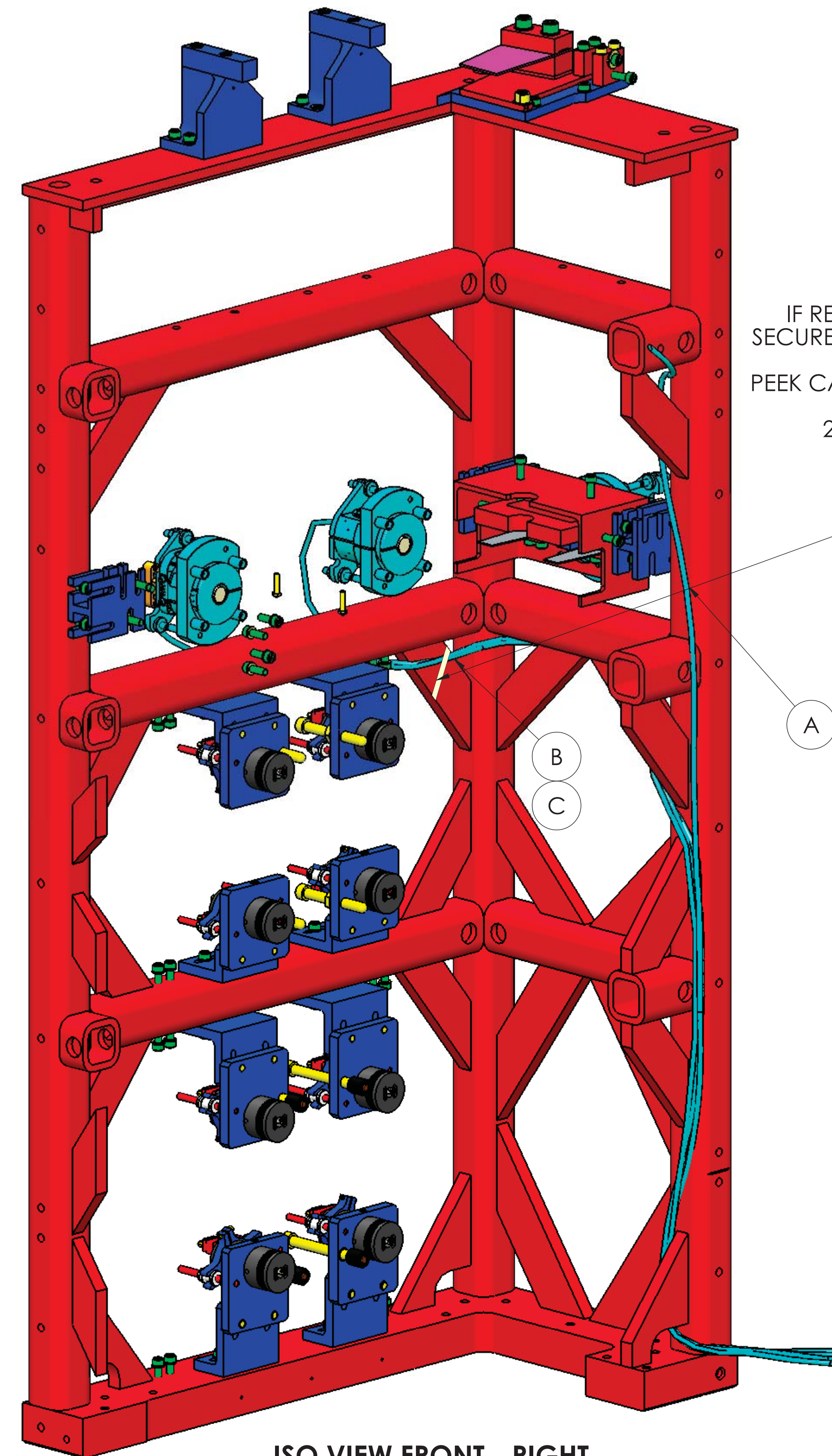

ISO VIEW FRONT - RIGHT
BROKEN OUT SECTION
(AS VIEWED FROM INSIDE)

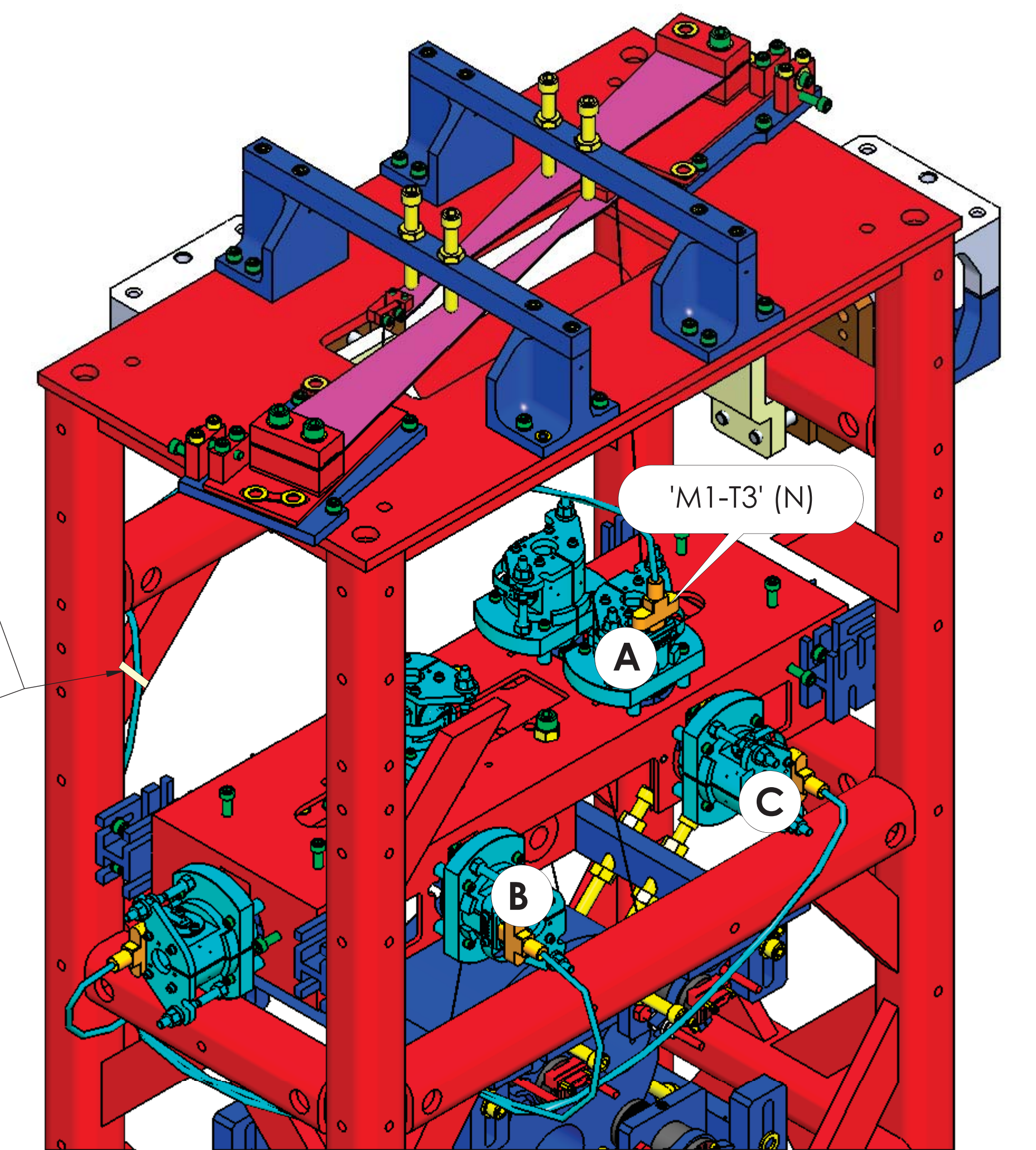

AR SIDE (1.1) (1.2)
ISO VIEW, REAR - LEFT (-X)

IF REQUIRED,
SECURE CABLES
USING
PEEK CABLE TIES
OR EQ.
2 PLACES

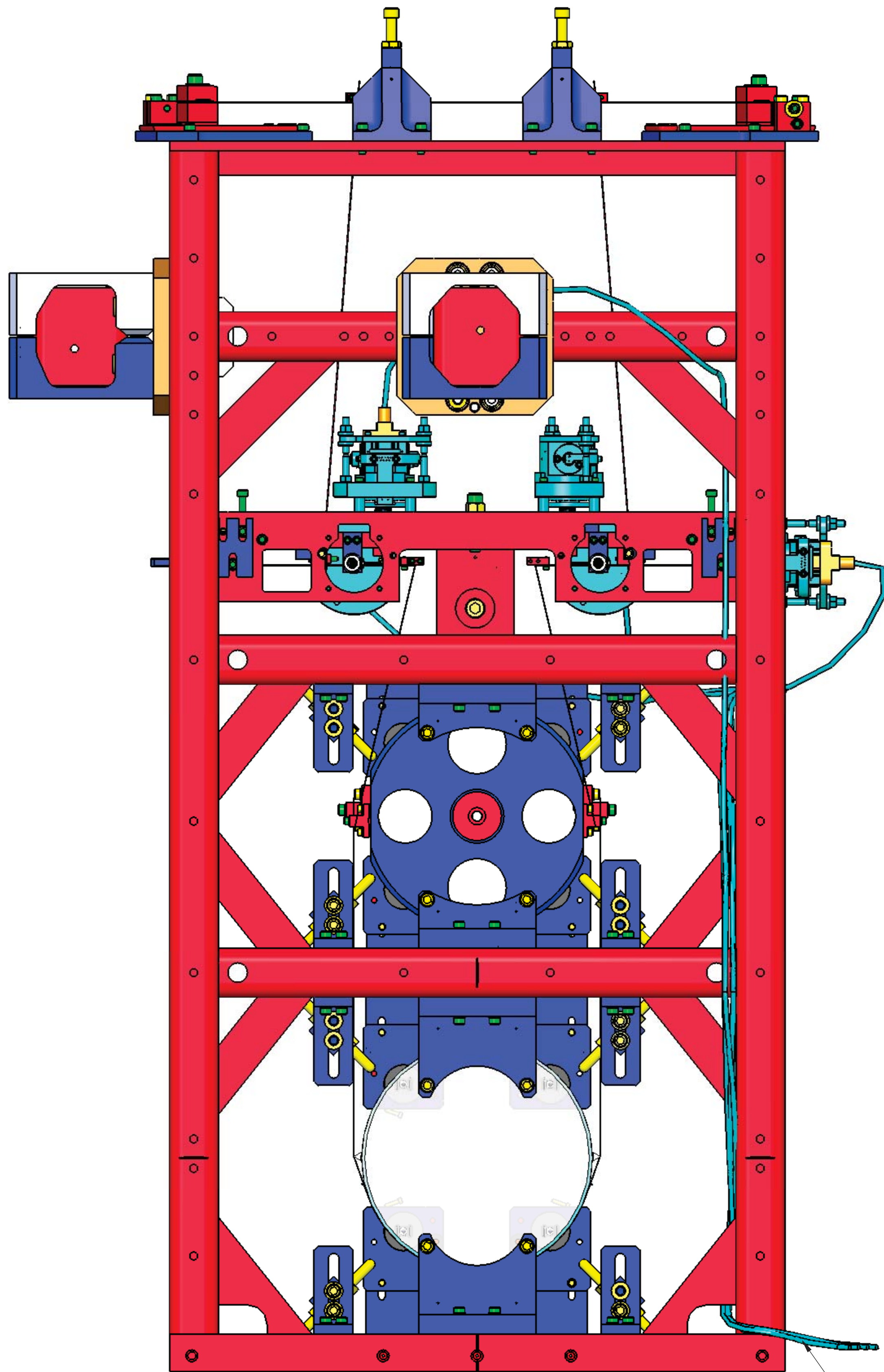

HR SIDE - FRONT (+X)
(END CONNECTORS, NOT SHOWN FOR CLARITY)

- A
- B
- C
- D

QP LEGS LACED
THROUGH
HR SIDE BOTTOM
RIGHT GUSSET

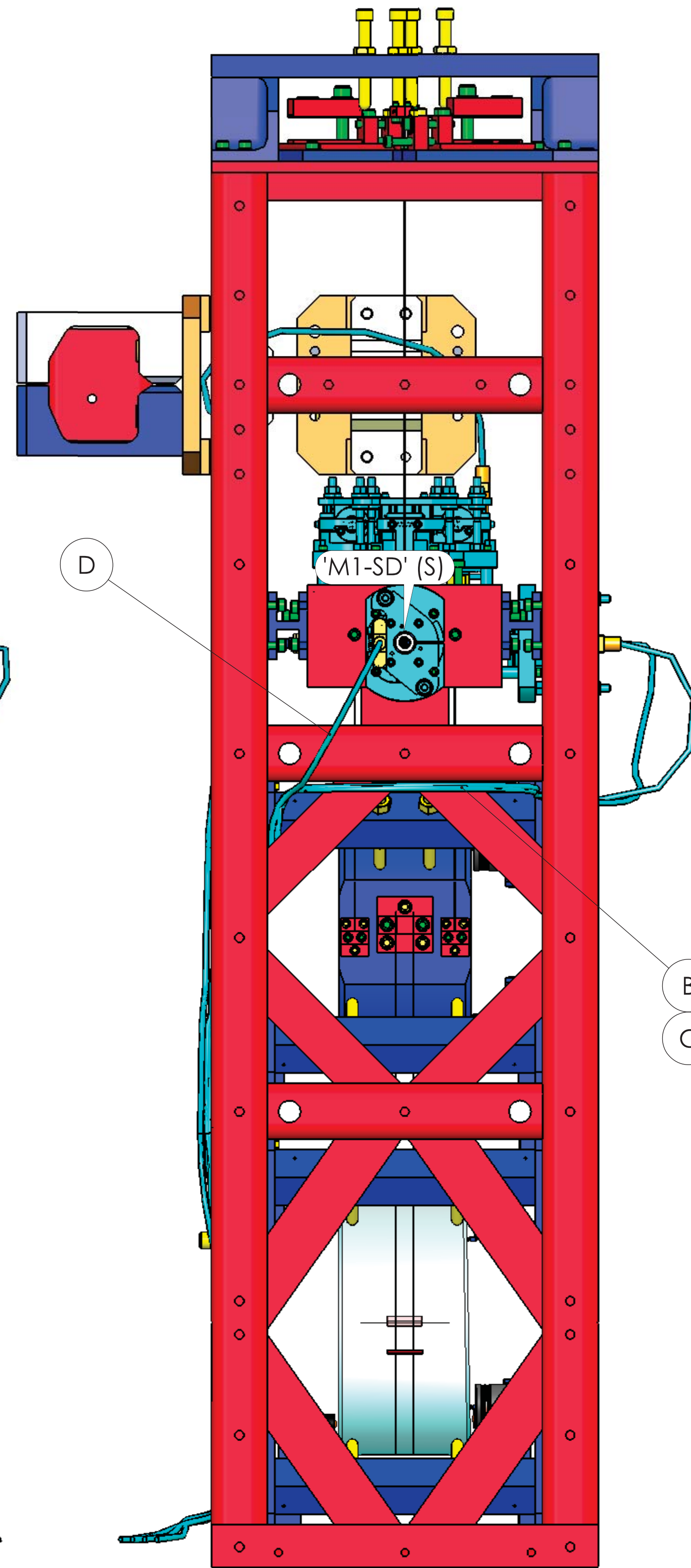

LEFT SIDE (+Y) (1.1) (1.2)



WARNING

CABLE ROUTING:
ROUTE ALL CABLES IN ACCORDANCE
WITH LIGO-T1200203 AND T1200318.
CABLE ROUTES DEPICTED
IN THIS DOCUMENT ARE NOT MANDATORY, BUT
RATHER A CONSIDERED ROUTE AIMED TO
CLEAR LASER BEAM PATHS.
ALTERNATE ROUTES FOR PROBLEMATIC AREAS
ARE ACCEPTABLE, BUT SHOULD BE HANDLED
IN A CASE BY CASE SITUATION. IT IS IMPERATIVE
TO CONSIDER THE LENGTH OF THE CABLE, THE
LOCATION OF MATING CABLE BRACKET,
AND LASER BEAM PATH PRIOR TO
ROUTING / LACING VIA A NEW PATH.

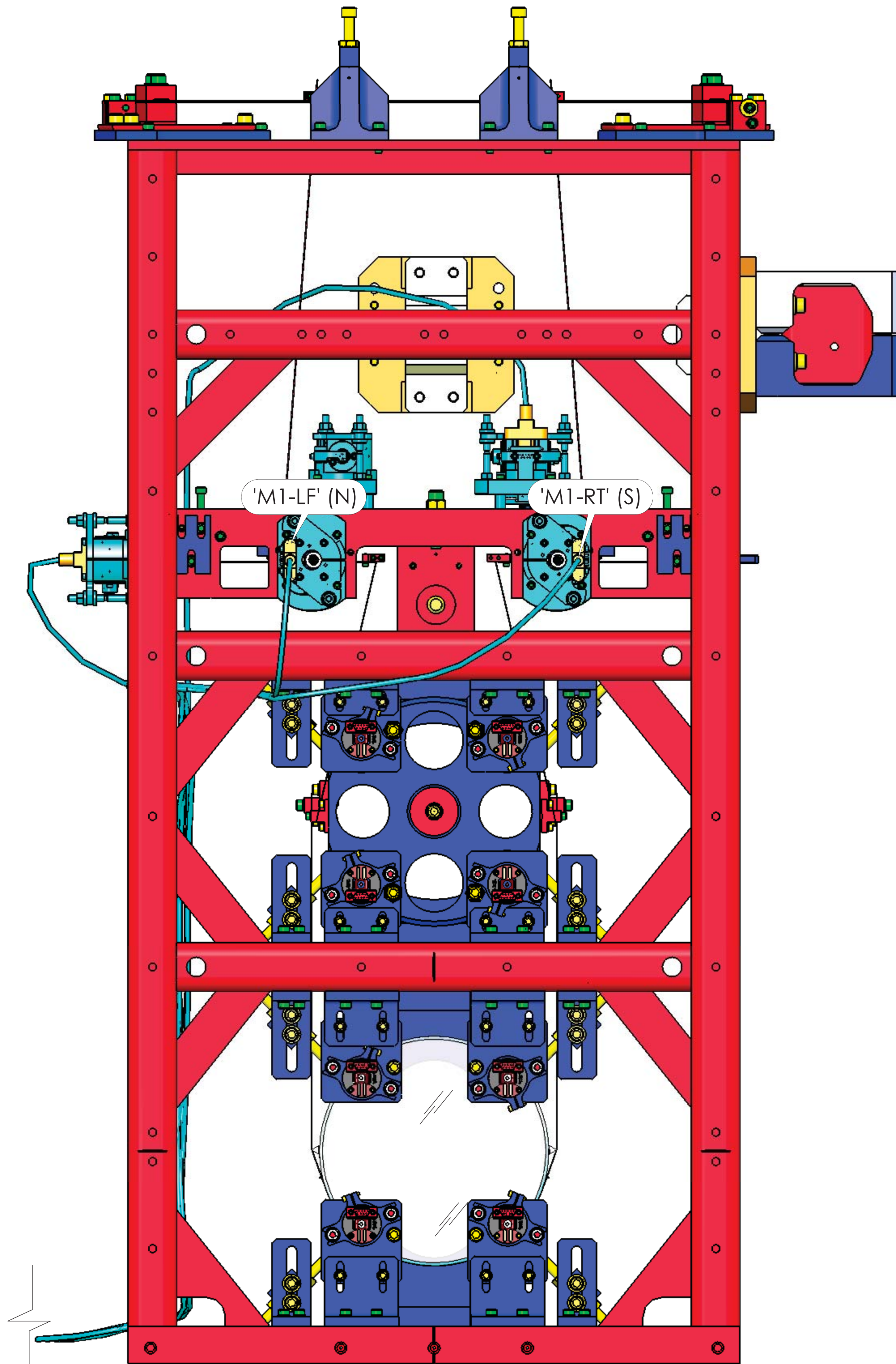
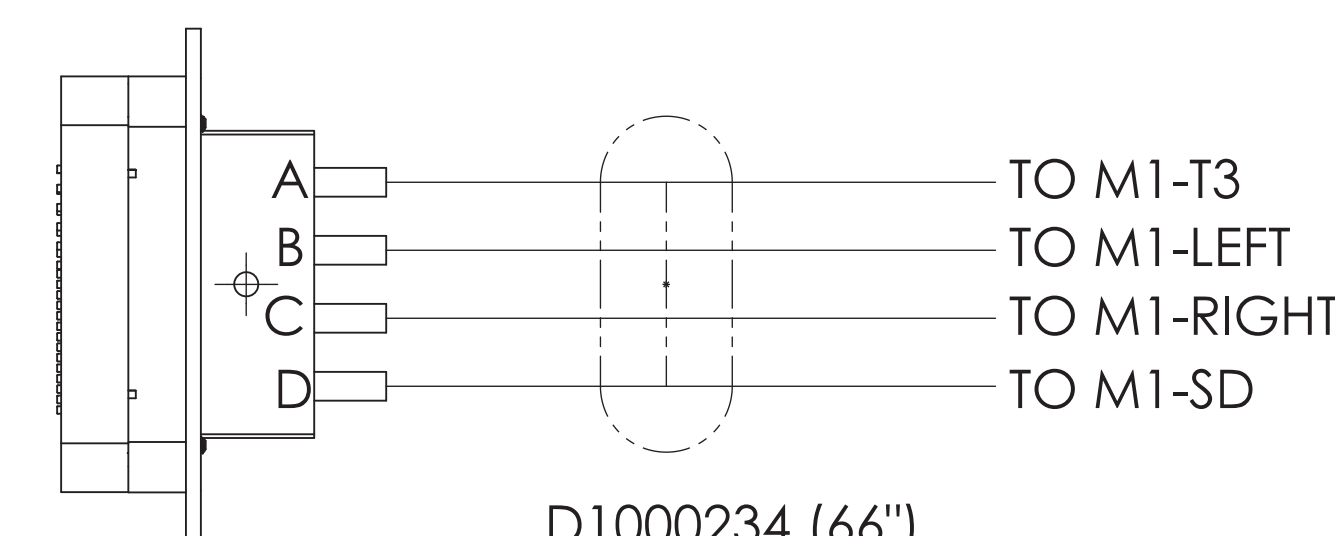
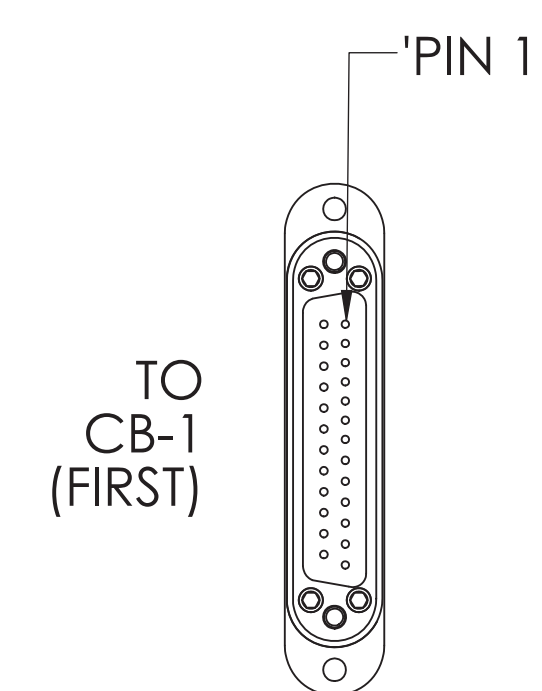

AR SIDE - REAR (-X) (1.1) (1.2)
(END CONNECTORS, NOT SHOWN FOR CLARITY)

ROUTE NO. 3

SEE LIGO-T1200318
FOR STEP BY STEP CABLING GUIDE

PR2

(SHARED)

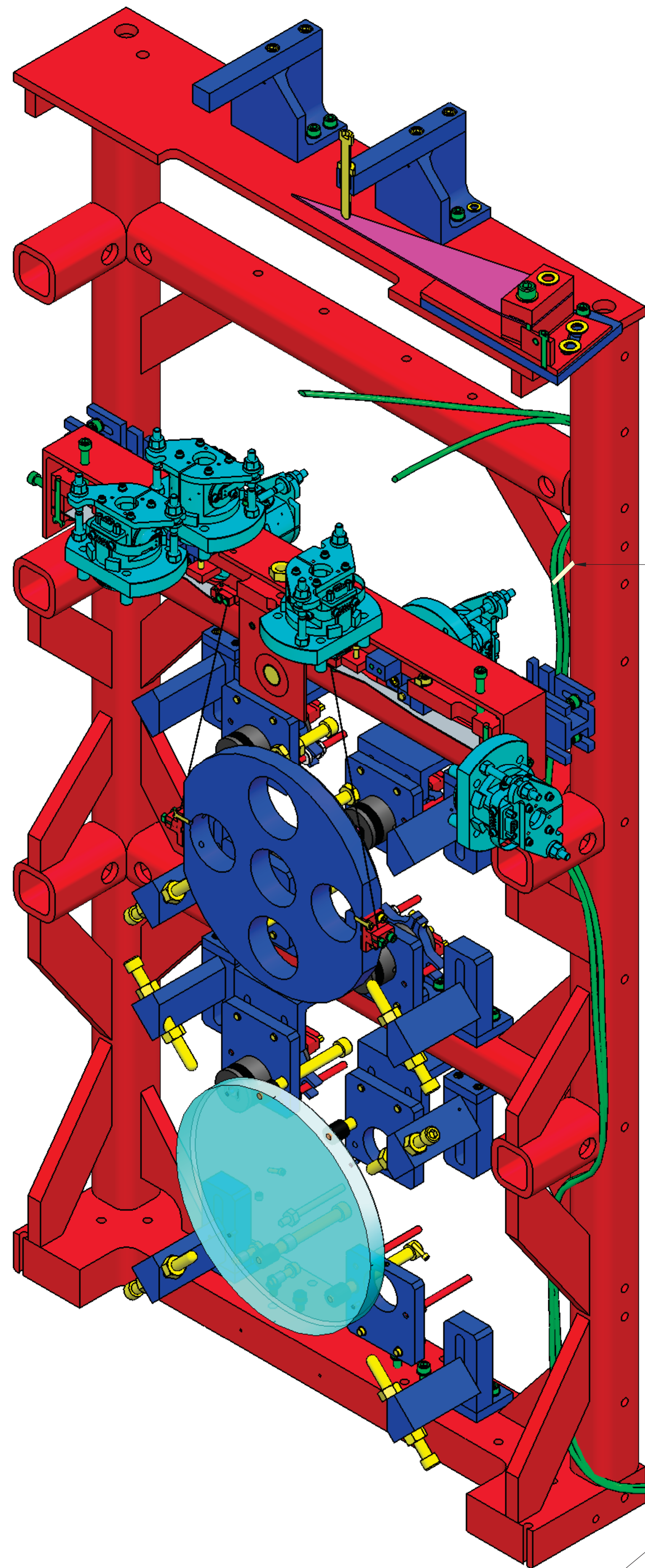

ISO VIEW FRONT - LEFT
BROKEN OUT SECTION
(AS VIEWED FROM INSIDE)

QP LEGS LACED
LEFT SIDE BOTTOM
RIGHT GUSSET

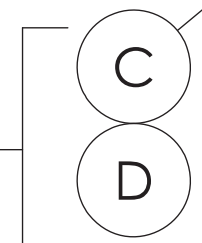

IF REQUIRED,
SECURE CABLES
USING
PEEK CABLE TIES
OR EQ.

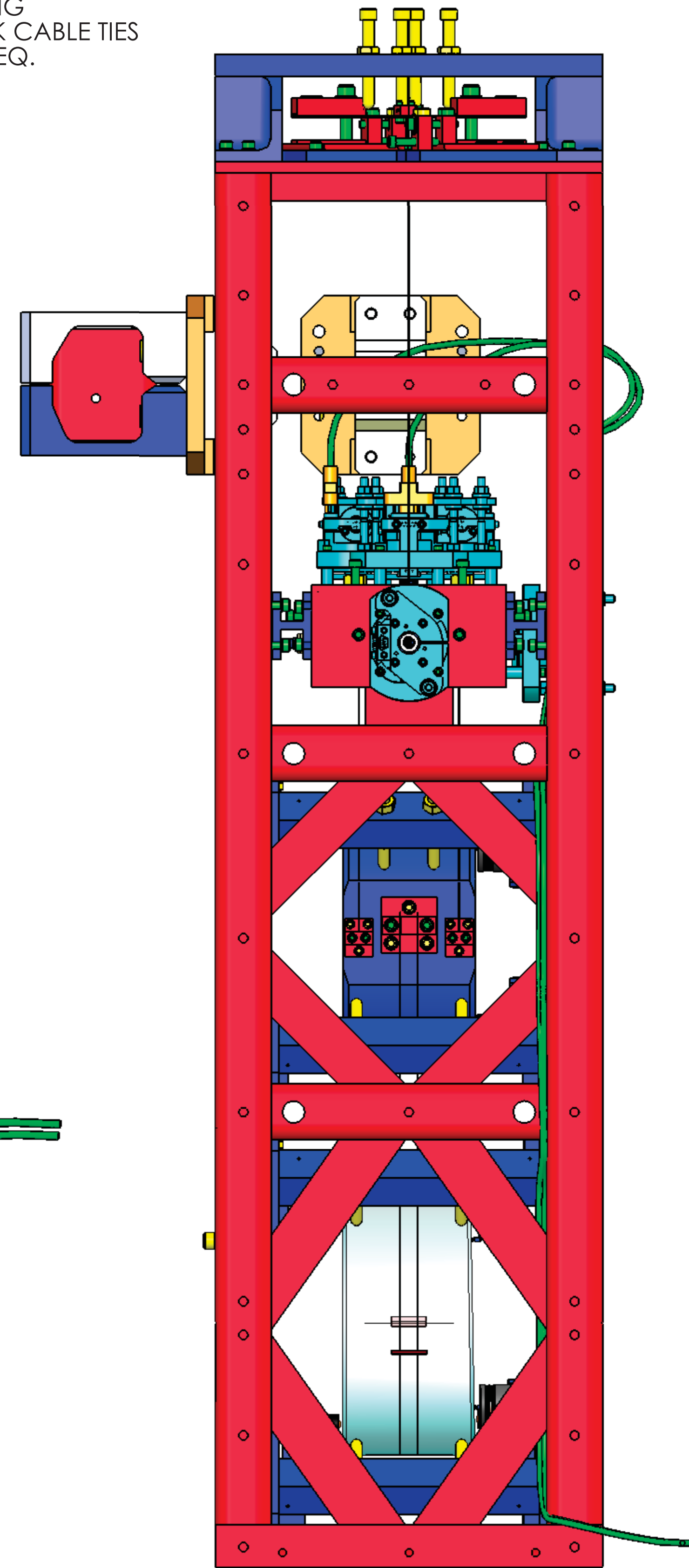
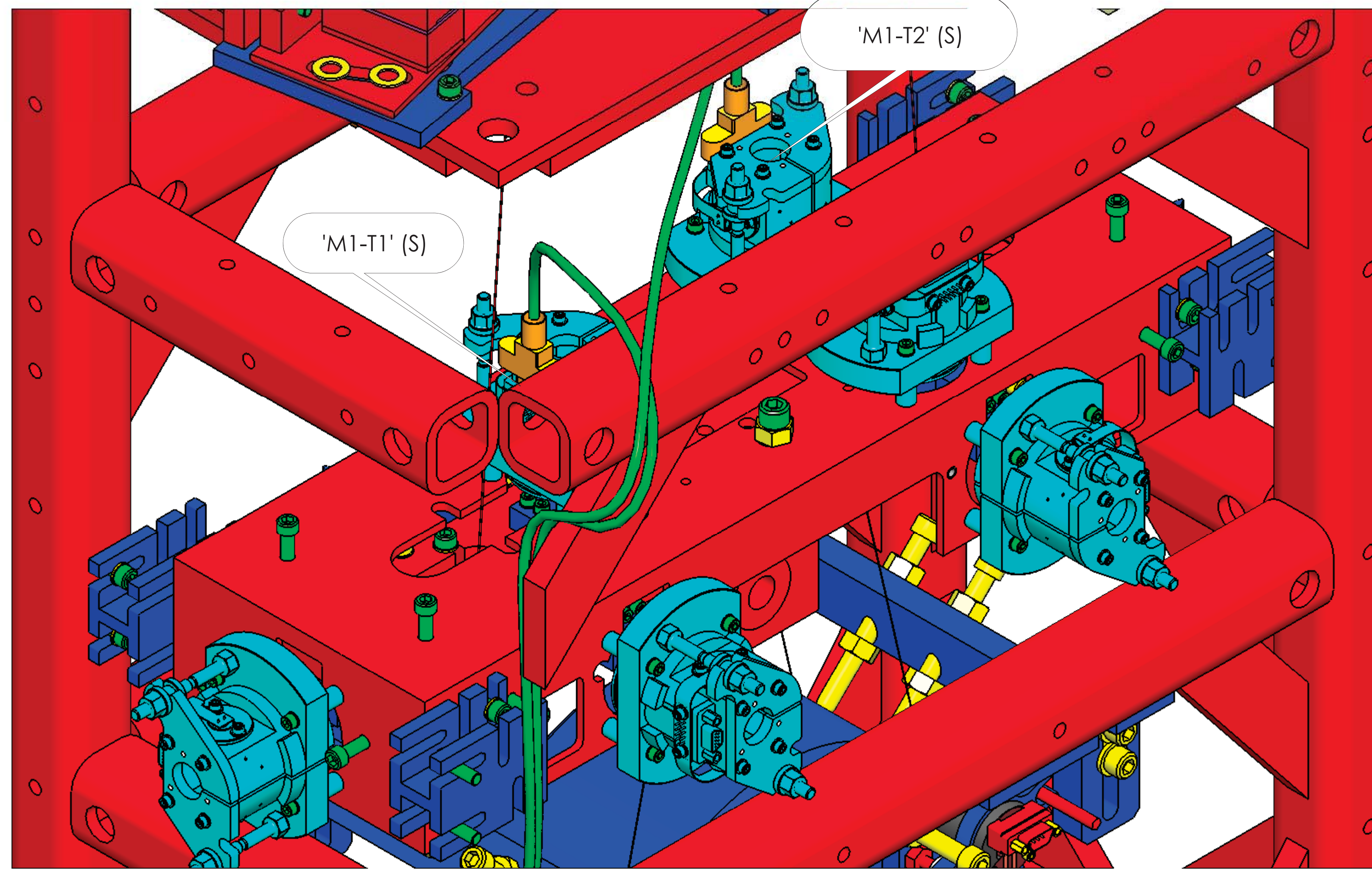

LEFT SIDE (+Y)

AR SIDE (1.1) (1.2)
ISO VIEW, REAR - LEFT (-X)



WARNING

CABLE ROUTING:
ROUTE ALL CABLES IN ACCORDANCE
WITH LIGO-T1200203 AND T1200318.
CABLE ROUTES DEPICTED
IN THIS DOCUMENT ARE NOT MANDATORY, BUT
RATHER A CONSIDERED ROUTE AIMED TO
CLEAR LASER BEAM PATHS.
ALTERNATE ROUTES FOR PROBLEMATIC AREAS
ARE ACCEPTABLE, BUT SHOULD BE HANDLED
IN A CASE BY CASE SITUATION. IT IS IMPERATIVE
TO CONSIDER THE LENGTH OF THE CABLE, THE
LOCATION OF MATING CABLE BRACKET,
AND LASER BEAM PATH PRIOR TO
ROUTING / LACING VIA A NEW PATH.

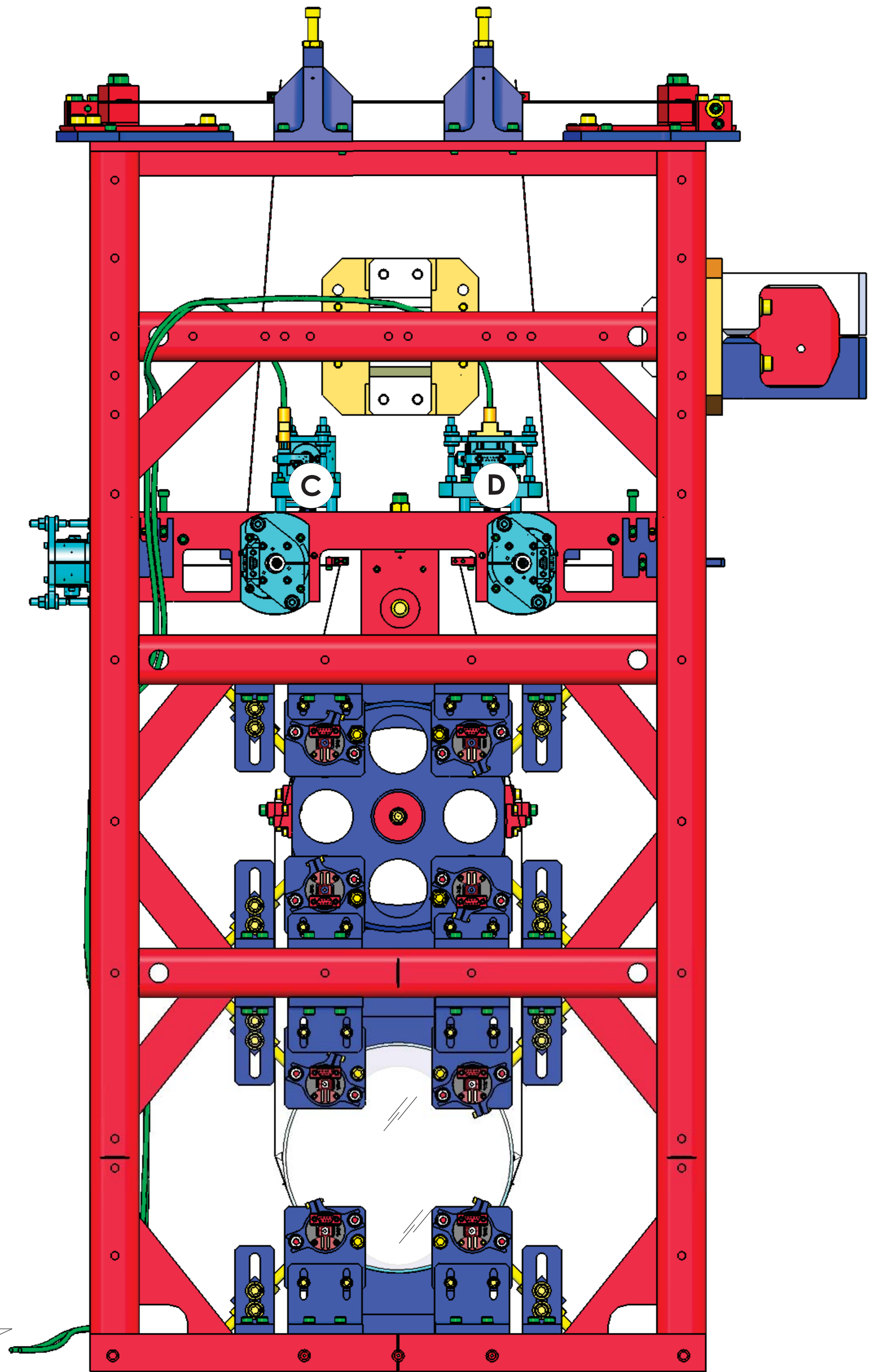
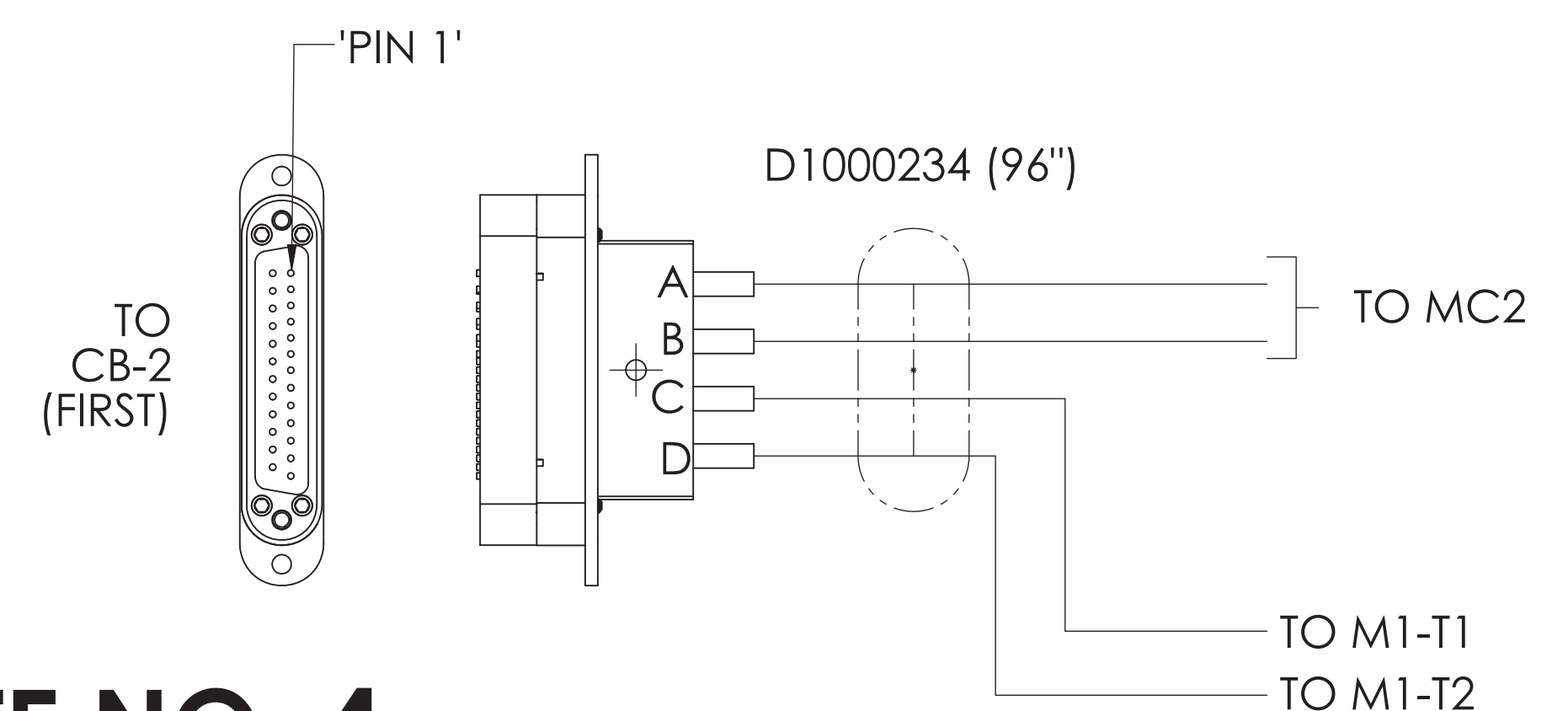

AR SIDE - REAR (-X)
(END CONNECTORS, NOT SHOWN FOR CLARITY)

ROUTE NO. 4
SEE LIGO-T1200318
FOR STEP BY STEP CABLING GUIDE

PR2

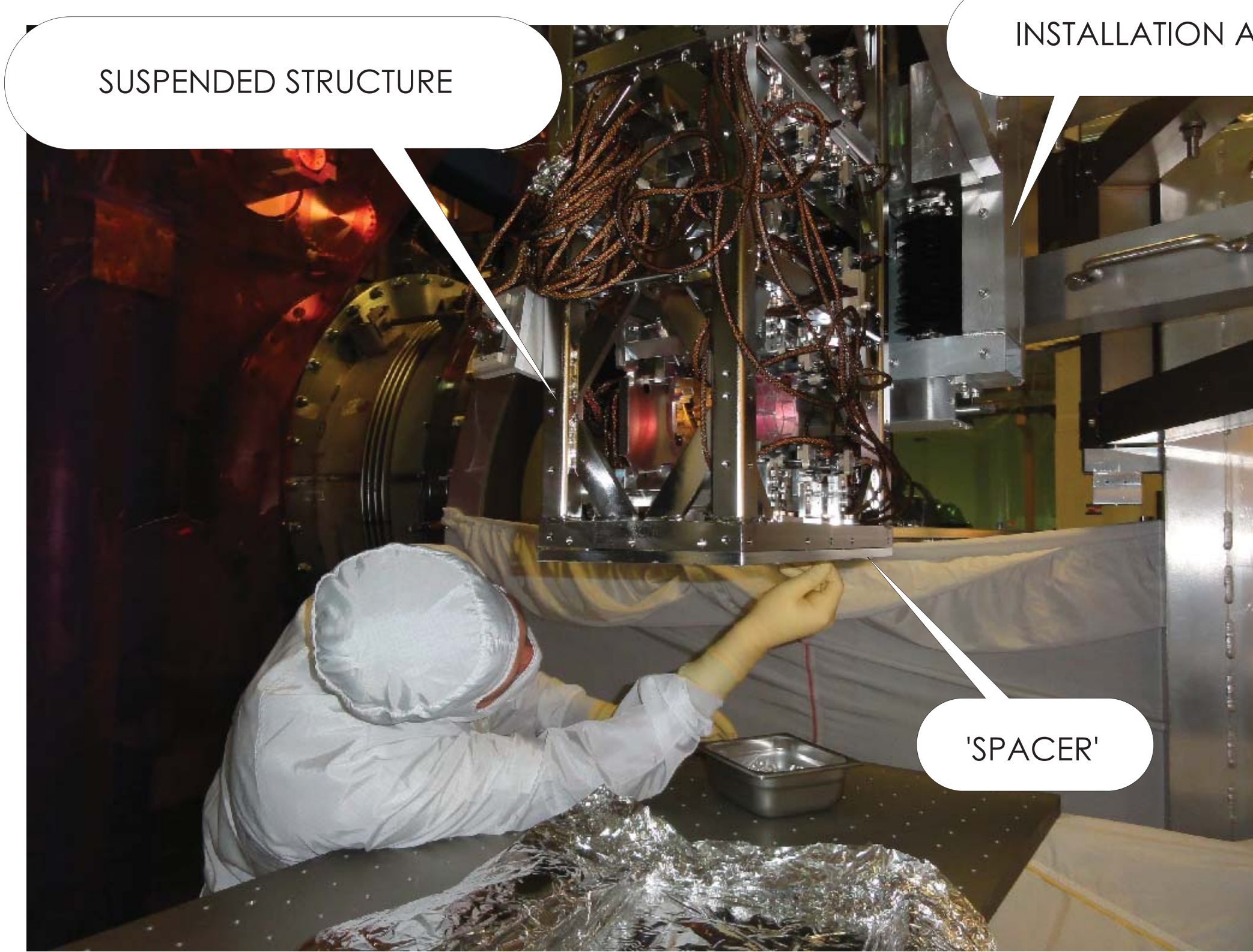
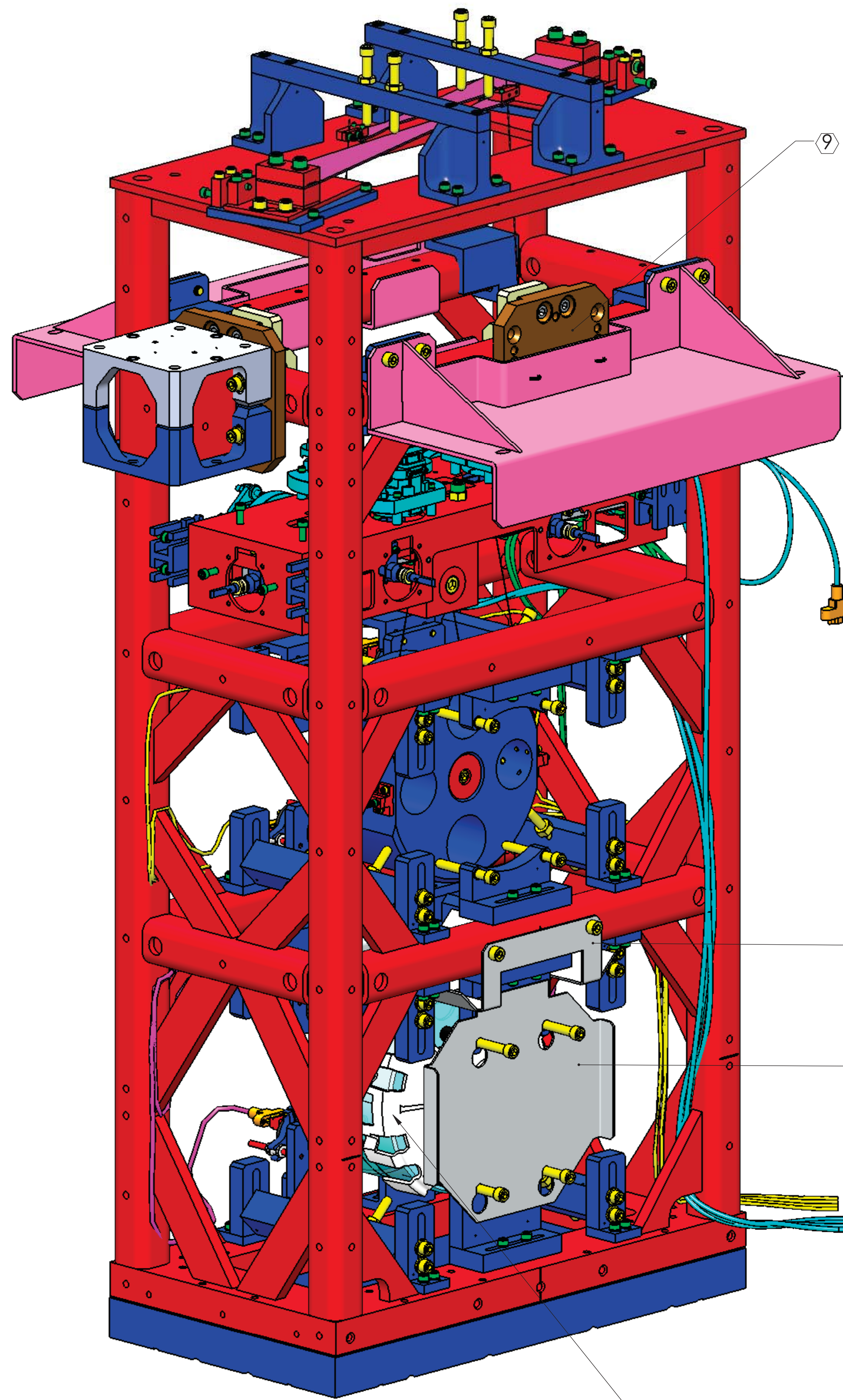

FIG 1.0: SPACER INSTALLATION

- ⑦ INDICATED ITEMS FOR TRANSPORTATION PURPOSES ONLY. AND ARE NOT PART OF FINISHED ASSEMBLY. SEE D1101674 FOR REFERENCE.
- ⑧ REMOVE INDICATED ITEMS FOR TRANSPORTATION PURPOSES. BUNDLE CABLES AS SHOWN.
- ⑨ REMOVE VIBRATION ABSORBER ON FRONT SIDE TO AVOID INTERFERENCE WITH LIFT BRACKET. 9.1 LOCKING PINS: RETAIN IN PLACE FOR TRANSPORTATION AND INSTALLATION ONLY. REMOVE BEFORE CHAMBER DOORS ARE CLOSED.
- ⑩ LIFT STRUCTURE VIA INSTALLATION ARM AT CHAMBER SIDE. ATTACHED ITEM 2 (SPACER) USING ITEM 6 (SCREW). TORQUE TO 75 IN LB. SEE FIG 1.0 FOR REFERENCE.



HR SIDE
ISO VIEW, FRONT - RIGHT (+X)

D1001788 ⑦ ⑨
HSTS LIFT BRACKET
QTY.2

D1102319 ⑦
HSTS OPTIC TOP SHIELD

D1102308 ⑦
HSTS FACE SHIELD

D1101443 ⑦
HSTS OPTICS CAP

D1101495 ⑦
HSTS BRACKET CLAMP RH
QTY.2

⑧ IF REQUIRED, BUNDLE CABLES AND ATTACH AS SHOWN TO THE SIDE OF THE STRUCTURE FOR TRANSPORTATION PURPOSES ONLY (SEE SHEET 6 FOR ROUTE DETAILS)

⑧ IF REQUIRED, BUNDLE CABLES AND ATTACH AS SHOWN TO THE SIDE OF THE STRUCTURE FOR TRANSPORTATION PURPOSES ONLY (SEE SHEET 7 FOR ROUTE DETAILS)

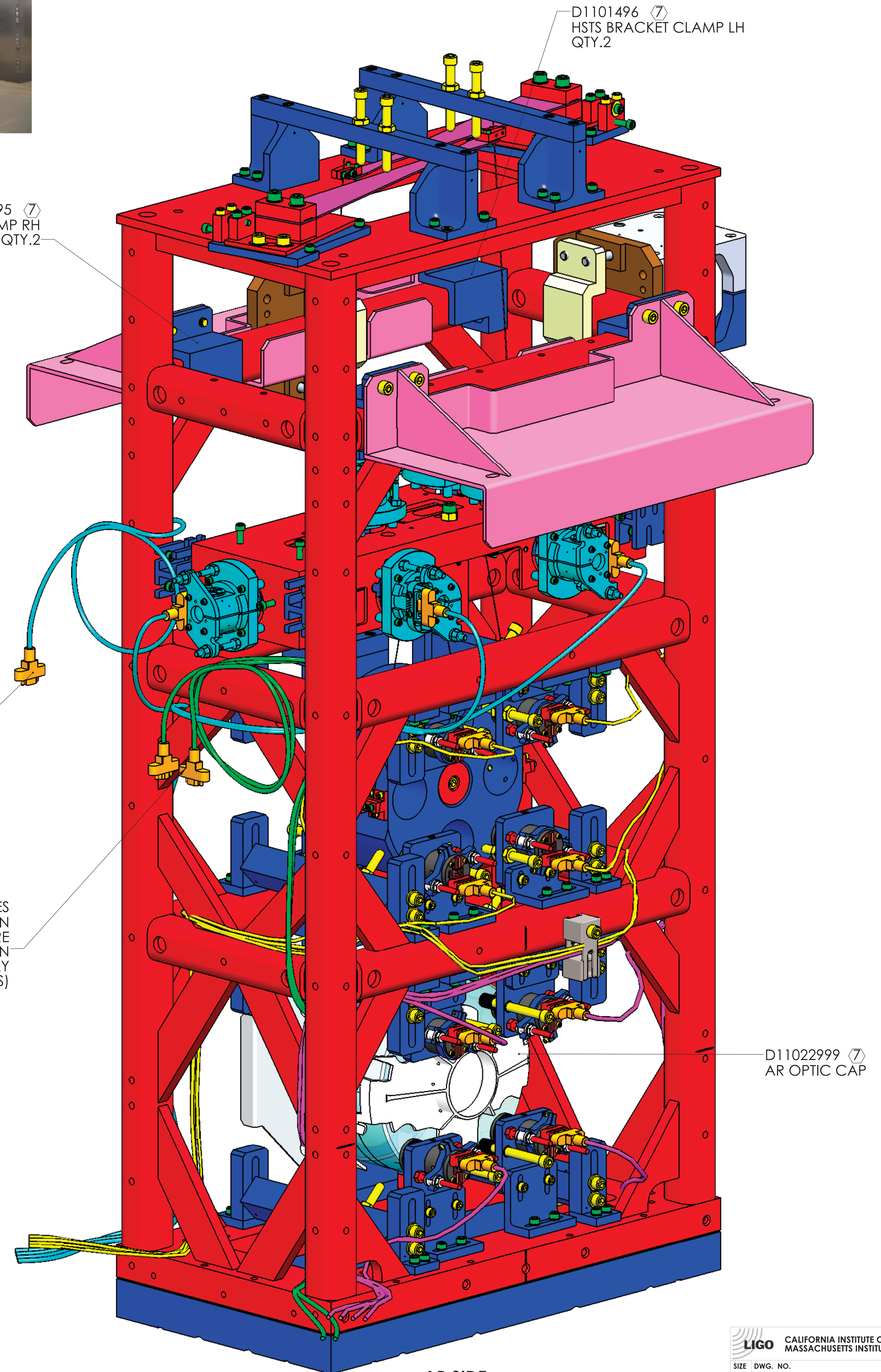

AR SIDE
ISO VIEW, REAR - LEFT (-X)

D1101496 ⑦
HSTS BRACKET CLAMP LH
QTY.2

D11022999 ⑦
AR OPTIC CAP

HSTS STRUCTURE TRANSP.

VIBRATION ABSORBERS ON FRONT SIDE NOT SHOWN (REMOVED FOR TRANSP. PURPOSES)

PR2

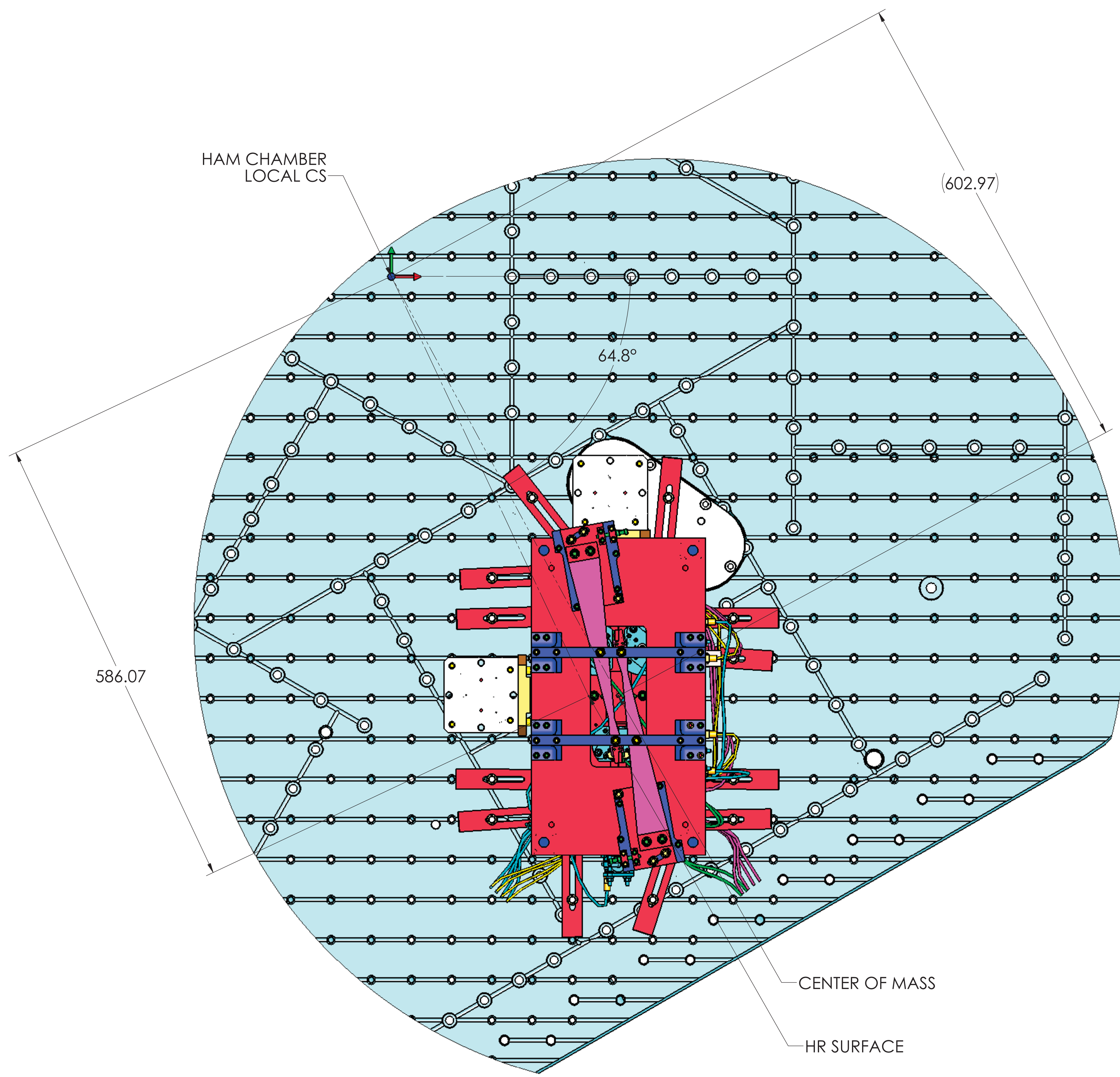
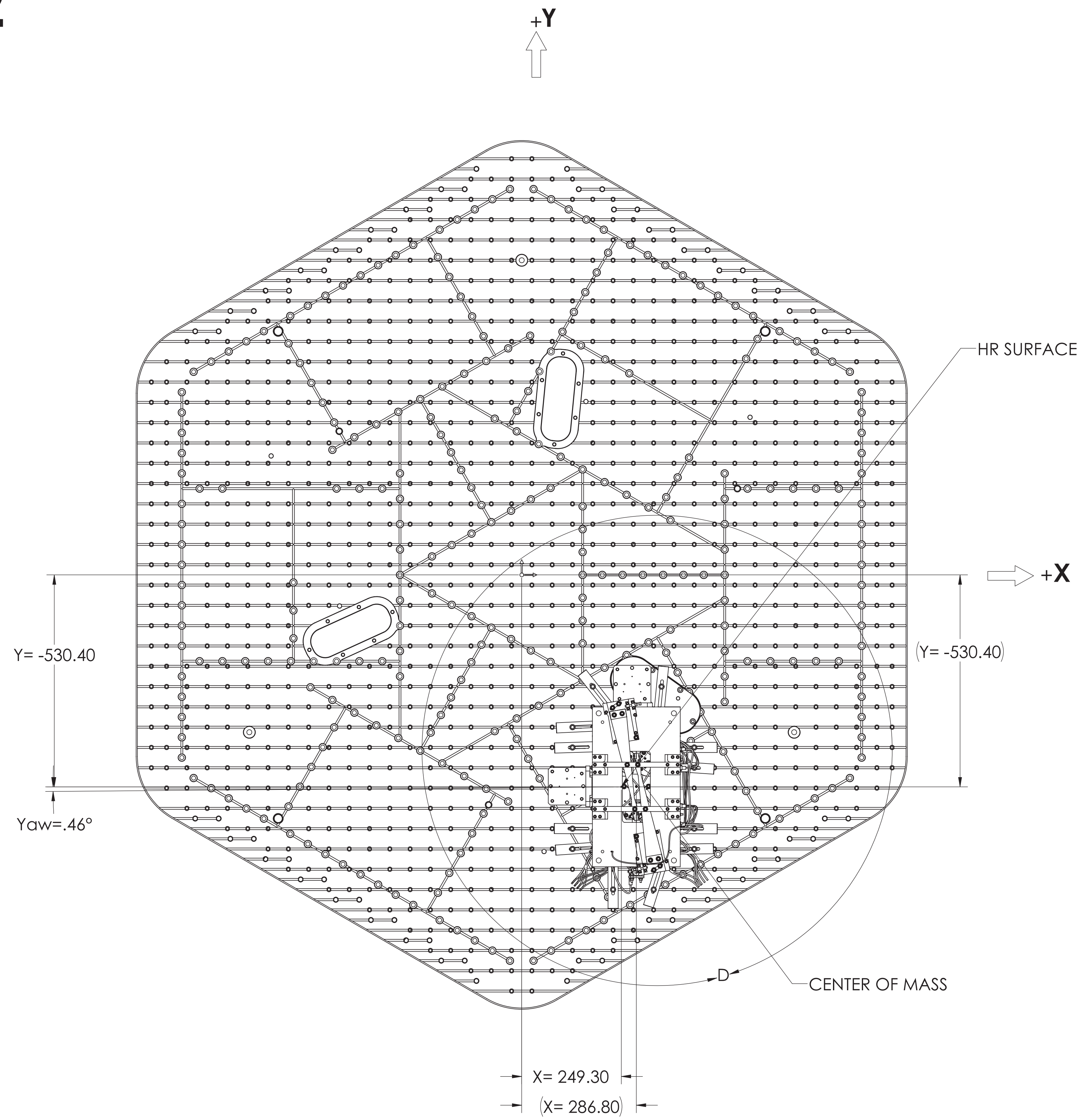

DETAIL D
SCALE 1 : 3

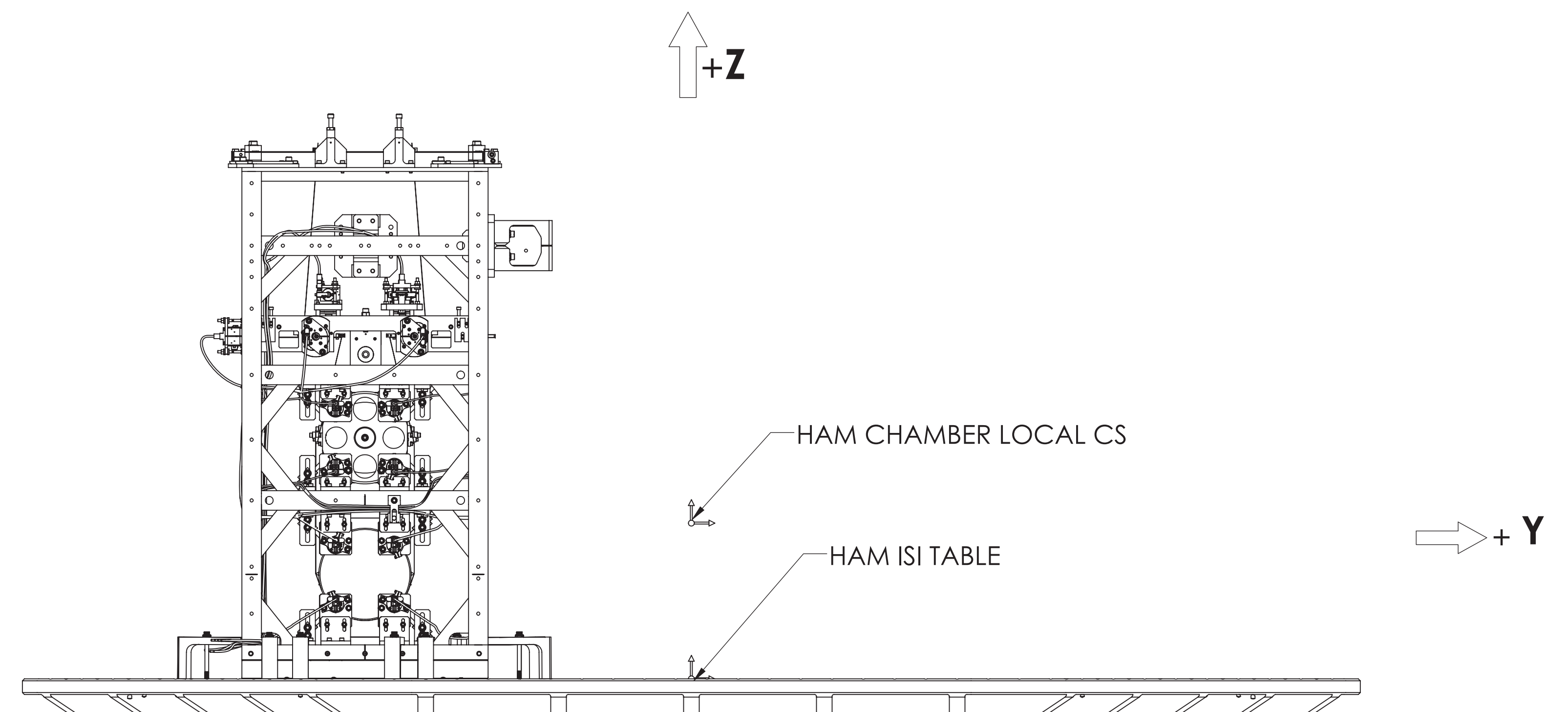
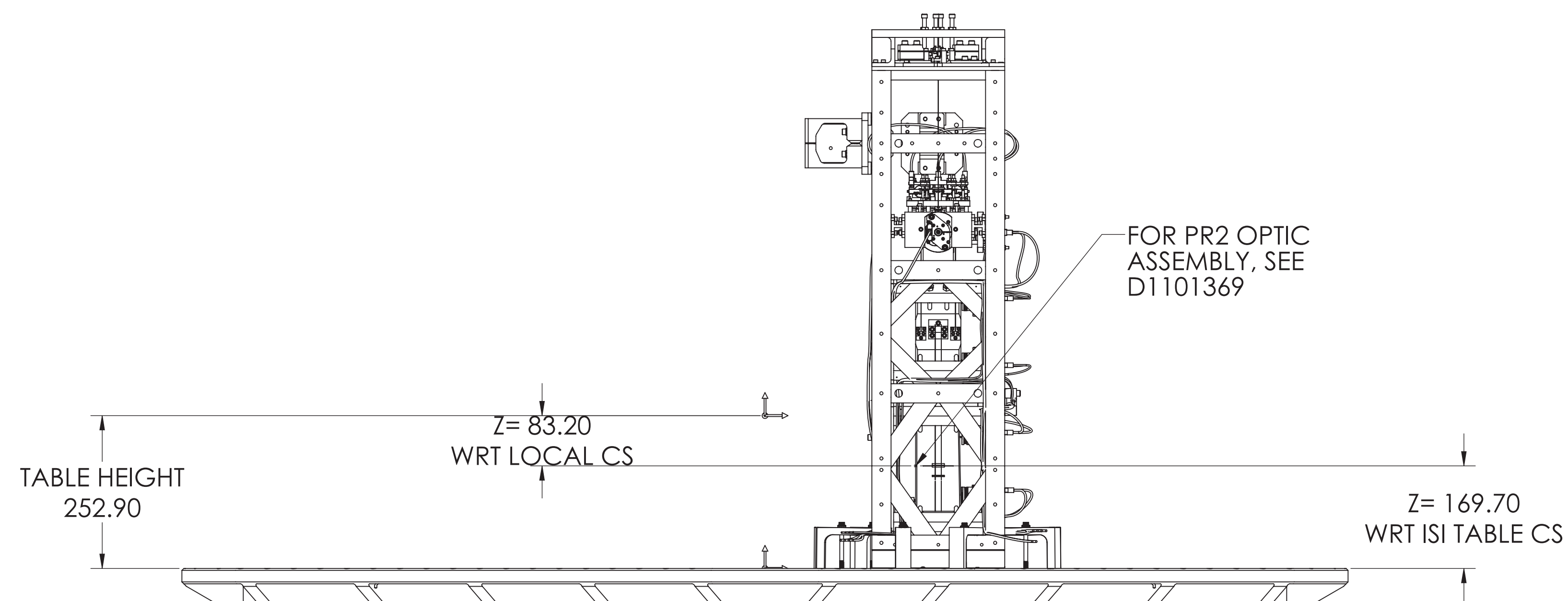

LOCAL COORDINATES DEFINITIONS

NOTE: DIMENSION IN PARENTHESIS (REFERENCE DIMENSIONS), ARE FROM CENTER OF MASS.