

4

3

2

1

NOTES CONTINUED:

Ⓢ BAG ALL ITEMS AND MARK OR TAG EACH BAG WITH DRAWING NUMBER, REVISION, AND QUANTITY. EXAMPLE: DXXXXXX-VY, QTY: TBD

REV.	DATE	DCN #	DRAWING TREE #
v1	3 MAR 2009	E0900066	-
v2	2 DEC 2009	E0900446	-
-	-	-	-

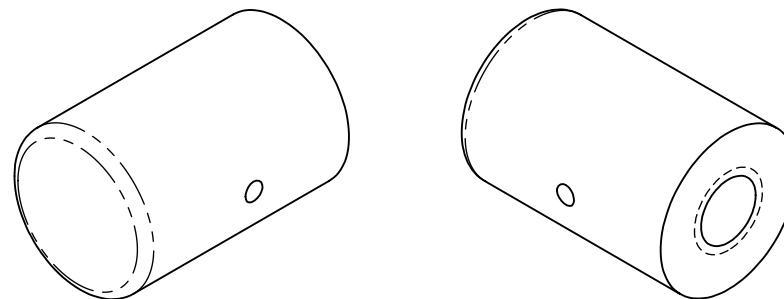

VENT HOLE ϕ .06 THRU TO THREADED HOLE

ϕ .20 ∇ .40
1/4-20 UNC ∇ .35

R.03

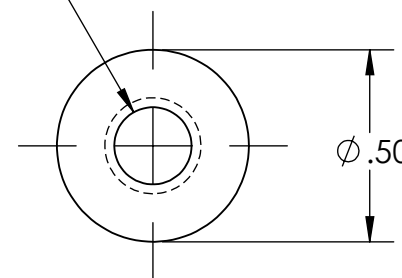
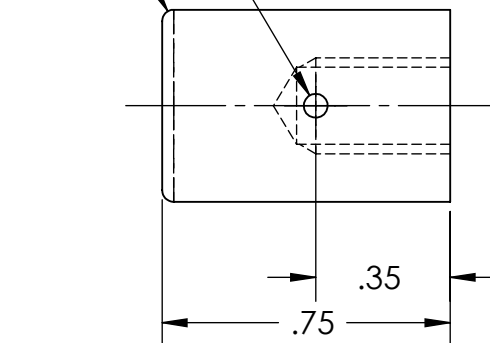
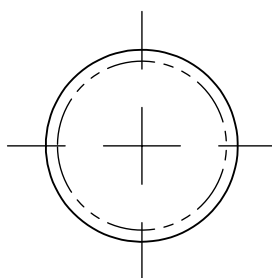

NOTES AND TOLERANCES: (UNLESS OTHERWISE SPECIFIED)

DIMENSIONS ARE IN INCHES

TOLERANCES:

.XX \pm .01
.XXX \pm .005

ANGULAR \pm 0.5°

1. INTERPRET DRAWING PER ASME Y14.5-1994.
2. REMOVE ALL SHARP EDGES, R.02 MIN.
3. DO NOT SCALE FROM DRAWING.
4. ALL MACHINING FLUIDS SHALL BE WATER SOLUBLE AND FREE OF SULFUR, CHLORINE AND SILICONE, SUCH AS CINCINNATI MILACRON'S CIMTECH 410.

MATERIAL PFA440 HP (Preshrunk)

FINISH N/A μ inch

LIGO CALIFORNIA INSTITUTE OF TECHNOLOGY
MASSACHUSETTS INSTITUTE OF TECHNOLOGY

SYSTEM ADVANCED LIGO

SUB-SYSTEM SUS

NEXT ASSY MULTIPLE ASSYS

PART NAME

CAP BODY, RESIN, EARTHQUAKE STOP

DESIGNER D. BRIDGES 14 MAY 2009

DRAFTER D. BRIDGES 15 DEC 2009

CHECKER M. MEYER 15 DEC 2009

APPROVAL

SIZE DWG. NO.

A

SCALE: 2:1

PROJECTION:

D080723

REV.

v2

SHEET 1 OF 1

4

3

2

1