

| REV. | DATE        | DCN #    | DRAWING TREE # |
|------|-------------|----------|----------------|
| v1   | 08 JUN 2009 | E0900166 | E080191        |
| -    | -           | -        | -              |
| -    | -           | -        | -              |

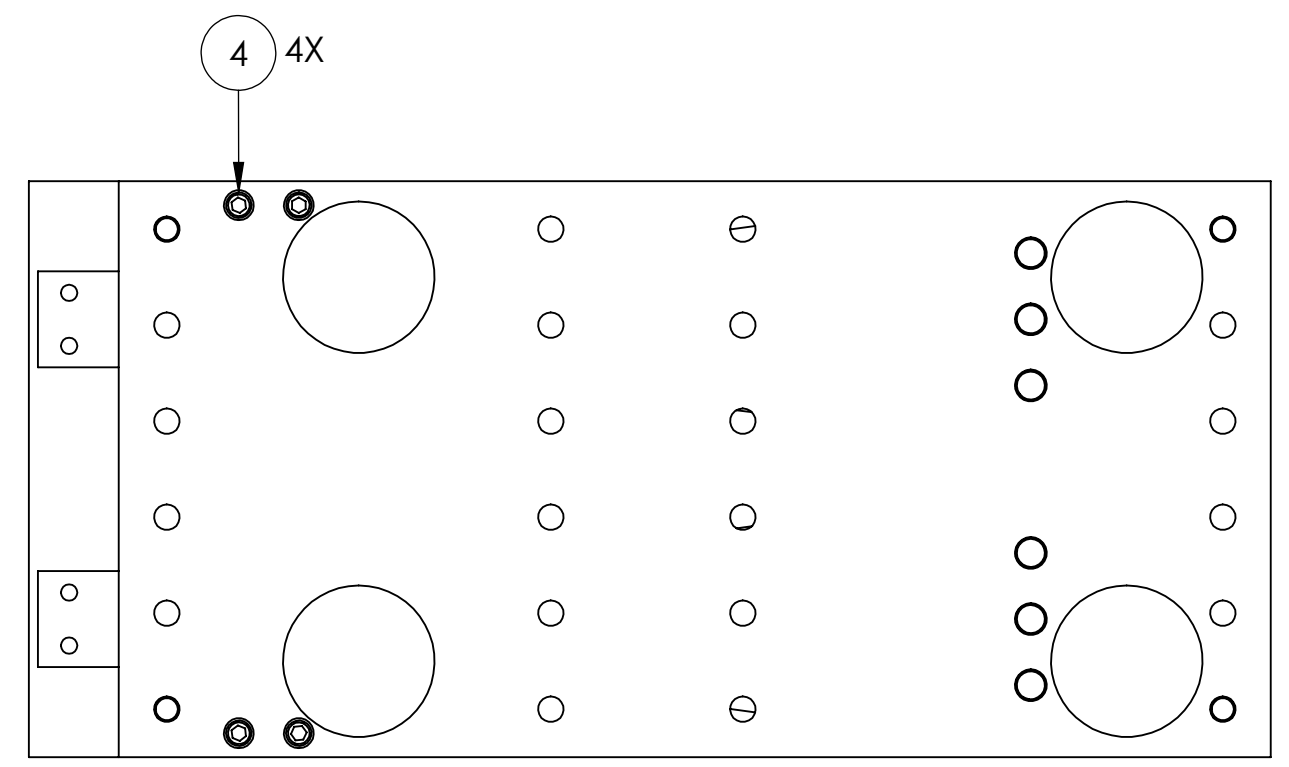
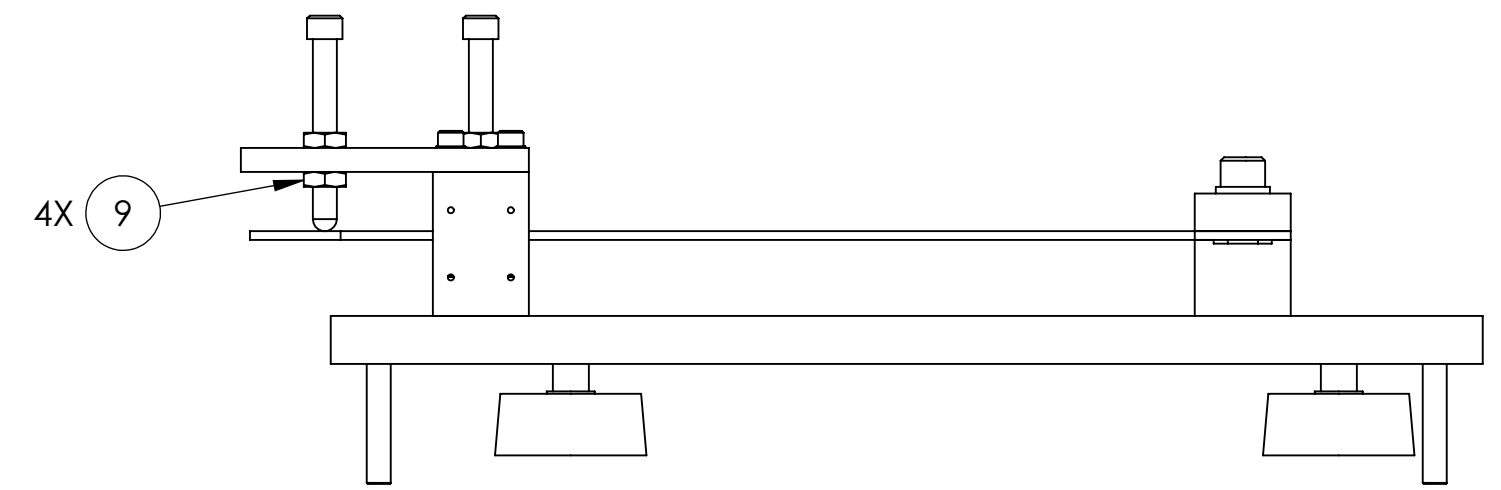
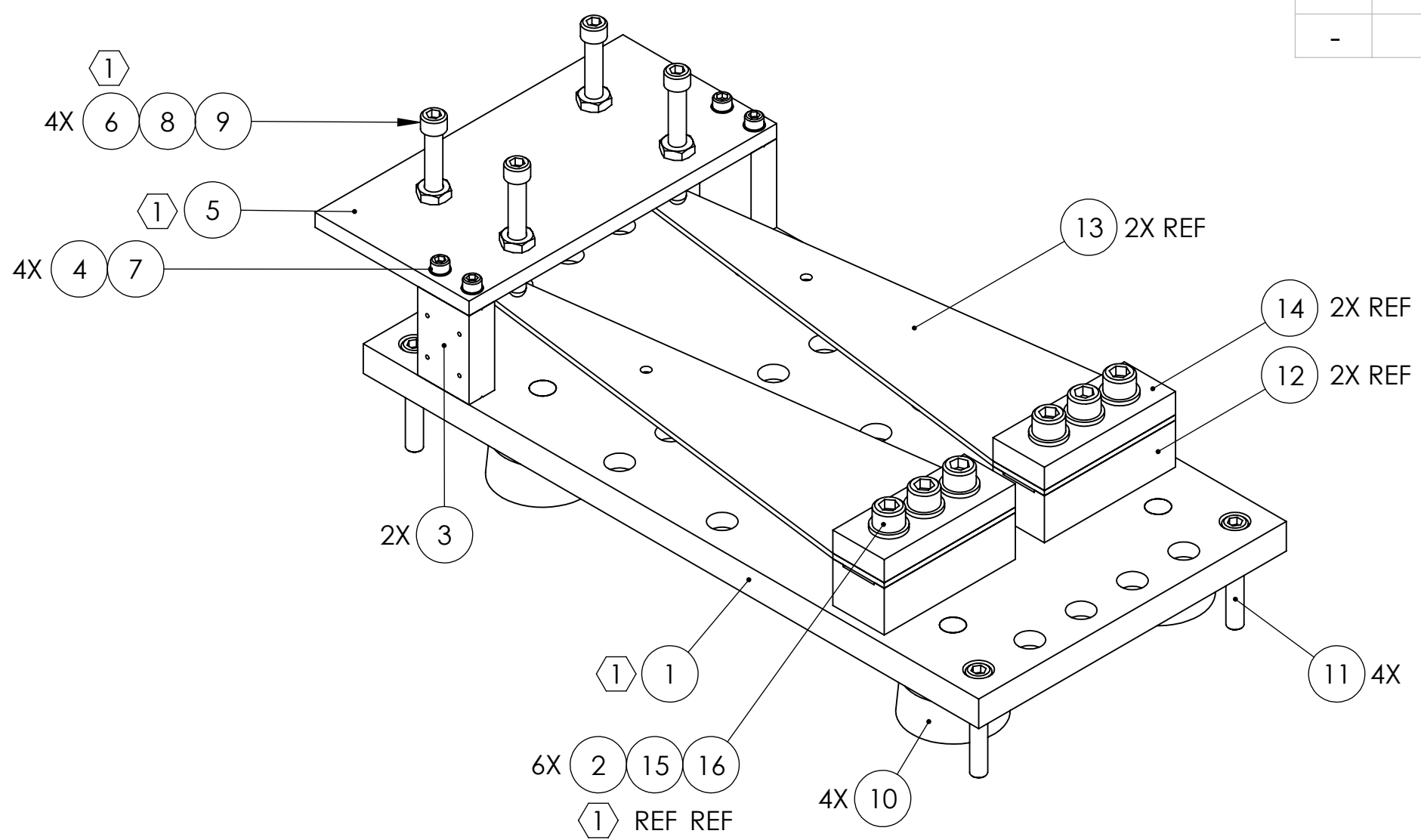

| ITEM NO.   | PART NUMBER | DESCRIPTION   | MATERIAL             | REQ | SPARE | TOTAL |
|------------|-------------|---|----------------------|-----|-------|-------|
| 16         | -           | SCREW, SOCKET HEAD CAP, 5/16-18 UNC-2A X 1.75 LONG                          | Ag-PLATED 300 SSSL   | REF | 0     | REF   |
| 15         | -           | WASHER, FLAT, 5/16 (NAS 1149-C516 OR EQUIVALENT)                            | 300 SSSL             | REF | 0     | REF   |
| 14         | D020601     | BLADE CLAMP, UPPER BLADE, OUTSIDE   | 304, 316 OR 302 SSSL | REF | 0     | REF   |
| 13         | D020617     | UPPER BLADE, HLTS   | MARAGING STEEL C250  | REF | 0     | REF   |
| 12         | D020622     | BLADE CLAMP, UPPER BLADE, INSIDE  | 304, 316 OR 302 SSSL | REF | 0     | REF   |
| 11         | -           | SCREW, SOCKET HEAD CAP, 1/4-20 UNC-2A X 1.5 LONG                            | 300 SSSL             | 4   | 4     | 8     |
| 10         | 83685T16    | LEVELING MOUNT (MCMaster-CARR P/N)  | 304 SSSL             | 4   | 1     | 5     |
| 9          | -           | JAM NUT, 1/4-20   | 300 SSSL             | 8   | 2     | 10    |
| 8          | D0901020    | SCREW, SOCKET HEAD CAP, 1/4-20 UNC-2A X 2 LONG, FULLY THREADED, ROUNDED END | Ag-PLATED 300 SSSL   | 4   | 1     | 5     |
| 7          | -           | WASHER, FLAT, #8 (NAS 620-C8L OR EQUIVALENT)                                | 300 SSSL             | 4   | 1     | 5     |
| 6          | 1185-4EN250 | HELICOIL, 1/4-20 X 0.25 LONG (1)  | NITRONIC 60          | 4   | 2     | 6     |
| 5          | D080267     | TOP BRIDGE (1)  | 304, 316 OR 302 SSSL | 1   | 0     | 1     |
| 4          | -           | SCREW, SOCKET HEAD CAP, #8-32 UNC-2A X 0.75 LONG                            | Ag-PLATED 300 SSSL   | 8   | 2     | 10    |
| 3          | D070558     | SIDE SUPPORT  | 304, 316 OR 302 SSSL | 2   | 0     | 2     |
| 2          | 1185-5EN469 | HELICOIL, 5/16-18 X 0.469 LONG (1)  | NITRONIC 60          | 6   | 4     | 10    |
| 1          | D080268     | BASE PLATE (1)  | 304, 316 OR 302 SSSL | 1   | 0     | 1     |
| PARTS LIST |             |   |                      |     |       |       |

NOTES AND TOLERANCES: (UNLESS OTHERWISE SPECIFIED)

(1) HELICOILS TO BE INSTALLED INTO ITEM NO. 1 AND ITEM NO. 5 BY LIGO PRIOR TO ASSEMBLY AND AFTER ALL PARTS ARE CLEANED AND BAKED.

MATERIAL: N/A  
FINISH: N/A μinch

**LIGO** CALIFORNIA INSTITUTE OF TECHNOLOGY  
MASSACHUSETTS INSTITUTE OF TECHNOLOGY

SYSTEM: ADVANCED LIGO      SUB-SYSTEM: SUS

NEXT ASSY: HLTS OVERALL ASSY AND FIXTURES

PART NAME: UPPER BLADE BAKE FIXTURE

DESIGNER: G. SCARBOROUGH 02 JUN 2008      SIZE: DWG. NO.      REV.:  
DRAFTER: D. BRIDGES 09 JUN 2009      C      D080265      v1  
CHECKER: M. MEYER 09 JUN 2009  
APPROVAL:      SCALE: 1:2      PROJECTION:      SHEET 1 OF 1