

NOTES CONTINUED:

- 5. SCRIBE, ENGRAVE, OR MECHANICALLY STAMP (NO INKS OR DYES) DRAWING PART NUMBER, REVISION (AND VARIANT OR "TYPE" IF APPLICABLE) ON NOTED SURFACE OF PART FOLLOWED ON THE NEXT LINE WITH A THREE DIGIT SERIAL NUMBER. SERIAL NUMBERS START AT 001 FOR THE FIRST ARTICLE AND PROCEED CONSECUTIVELY. USE MINIMUM 0.12" HIGH CHARACTERS, UNLESS THE SIZE OF THE PART DICTATES SMALLER CHARACTERS. A VIBRATORY TOOL MAY BE USED.
EXAMPLE: DXXXXXX-VY, TYPE-XX, S/N XXX
- 6. MACHINE ALL SURFACES TO REMOVE OXIDES AND MILL FINISH. USE OF ABRASIVE REMOVAL TECHNIQUES IS NOT ALLOWED.
- 7. ALL PARTS SHALL BE MANUFACTURED IN ACCORDANCE WITH LIGO SPECIFICATION E0900364.
- 8. ALL HELICOIL HOLES TO BE PREPARED IN ACCORDANCE WITH EMHART HELICOIL PRODUCT CATALOG, HC2000, REV. 4.
- 9. ALL HELICOILS TO BE INSTALLED BY LIGO PERSONNEL AFTER DELIVERY, CLEANING AND BAKING OF FINISHED PARTS.

REV.	DATE	DCN #	DRAWING TREE #
v1	02 JUN 2009	E0900162	E080191
v2	28 JUN 2010	E1000236	E080191
-	-	-	-

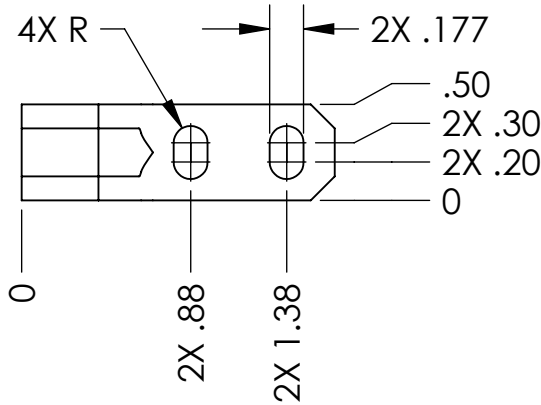
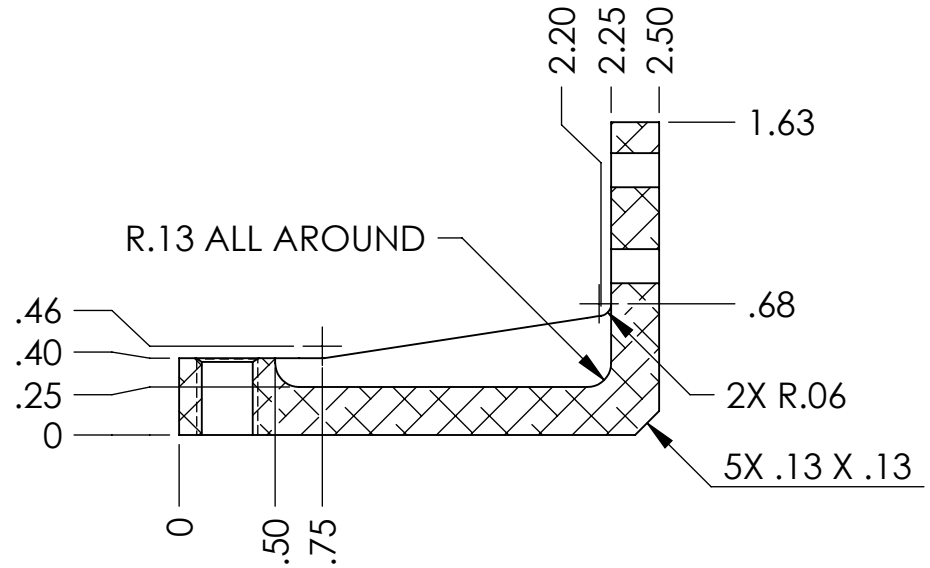
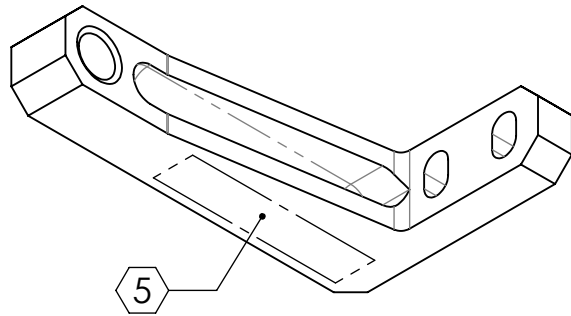

SECTION A-A

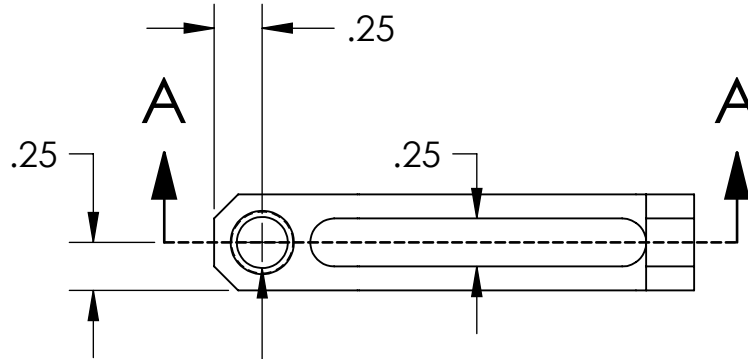

DRILL AND TAP THRU FOR
1/4-20 UNC-2B X 1.5 DIA
EMHART HELICOIL
(P/N 1185-4EN375)

NOTES AND TOLERANCES: (UNLESS OTHERWISE SPECIFIED)

DIMENSIONS ARE IN INCHES

TOLERANCES:
.XX ± .01
.XXX ± .005

ANGULAR ± 0.5°

- 1. INTERPRET DRAWING PER ASME Y14.5-1994.
- 2. REMOVE ALL SHARP EDGES, R.02 MIN.
- 3. DO NOT SCALE FROM DRAWING.
- 4. ALL MACHINING FLUIDS MUST BE FULLY SYNTHETIC, FULLY WATER SOLUBLE AND FREE OF SULFUR, SILICONE, AND CHLORINE.

MATERIAL 6061-T6 Al
FINISH 63 μinch



SYSTEM ADVANCED LIGO SUB-SYSTEM SUS

NEXT ASSY EARTHQUAKE STOP ASSY, LONG BRACKET

PART NAME EARTHQUAKE STOP BRACKET, LONG

DESIGNER	D. BRIDGES	16 NOV 2008	SIZE	DWG. NO.	REV.
DRAFTER	D. BRIDGES	02 NOV 2010	A	D070322	v2
CHECKER	B. MOORE	03 NOV 2010	SCALE: 1:1	PROJECTION:	SHEET 1 OF 1