

4

3

2

1

NOTES CONTINUED:

5 SCRIBE, ENGRAVE, OR MECHANICALLY STAMP (NO INKS OR DYES) DRAWING PART NUMBER AND REVISION ON NOTED SURFACE FOLLOWED ON THE NEXT LINE BY A THREE DIGIT SERIAL NUMBER. SERIAL NUMBERS START AT 001 FOR THE FIRST ARTICLE AND PROCEED CONSECUTIVELY. USE .07" HIGH CHARACTERS. EXAMPLE: DXXXXX-VY, S/N 001. A VIBRATORY TOOL MAY BE USED.

REV.	DATE	DCN #	DRAWING TREE #
v1	22 JUN 2009	E0900173	E080191
-	-	-	-
-	-	-	-

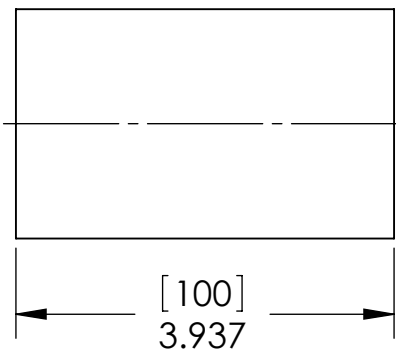
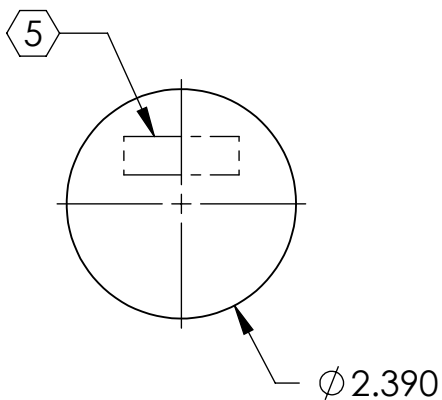
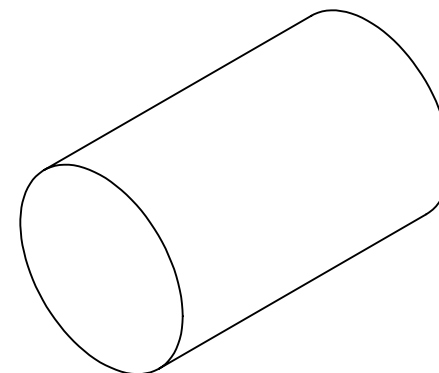

NOTES AND TOLERANCES: (UNLESS OTHERWISE SPECIFIED)

DIMENSIONS ARE IN INCHES [MM]  
 TOLERANCES:  
 .XX ± .01  
 .XXX ± .005  
 ANGULAR ± 0.5°

1. INTERPRET DRAWING PER ASME Y14.5-1994.
2. REMOVE ALL SHARP EDGES, R.02 MIN.
3. DO NOT SCALE FROM DRAWING.
4. ALL MACHINING FLUIDS SHALL BE WATER SOLUBLE AND FREE OF SULFUR, CHLORINE AND SILICONE, SUCH AS CINCINNATI MILACRON'S CIMTECH 410.

MATERIAL: 6061-T6 Al  
 FINISH: 32 μinch

**LIGO** CALIFORNIA INSTITUTE OF TECHNOLOGY  
 MASSACHUSETTS INSTITUTE OF TECHNOLOGY

SYSTEM: **ADVANCED LIGO** SUB-SYSTEM: **SUS**

NEXT ASSY: **INTERMEDIATE MASS ASSY**

PART NAME: **SIDE OFFSET**

DESIGNER: G. SCARBOROUGH	14 APR 2008	SIZE: A	DWG. NO.: <b>D030156</b>	REV.: v1
DRAFTER: D. BRIDGES	24 JUN 2009			
CHECKER: M. MEYER	24 JUN 2009			
APPROVAL:		SCALE: 1:2	PROJECTION:	SHEET 1 OF 1

4

3

2

1