

REV.	DATE	DCN #	DRAWING TREE #
A	JUL 2004	E040303-00	E030507-A
B	30 MAY 2008	E080195-00-D	

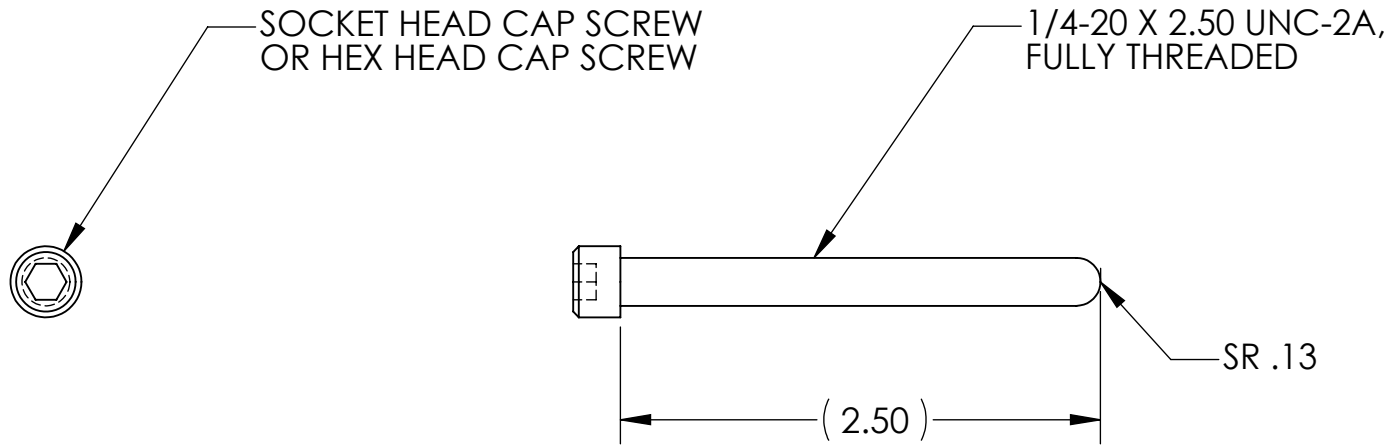

NOTES: (UNLESS OTHERWISE SPECIFIED)

1. DO NOT SCALE FROM DRAWING.
2. REMOVE ALL SHARP EDGES, R.02 MAX.
3. ALL MACHINING FLUIDS SHALL BE WATER SOLUBLE AND FREE OF SULFUR, CHLORINE AND SILICONE.

DIMENSIONS ARE IN INCHES

TOLERANCES:

.XX ± 0.01
.XXX ± 0.005

ANGULAR ± 0.5 °

MATERIAL

316 SSTL

FINISH

	NAME	DATE
DRAWN	J. ROMIE	JAN 2003
CHECKED	D. BRIDGES	14 MAY 2008
APPROVED		



SYSTEM **ADVANCED LIGO**

SUB-SYSTEM **SUS**

NEXT ASSY **MODE CLEANER SUS**

PART NAME **SHCS, 1/4-20 X 2.5,
ROUNDED END**

SIZE **A** DWG. NO. **D030021**

REV. **B**

SCALE: 1:1 PROJECTION: SHEET 1 OF 1