

NOTES CONTINUED:

- 5. SCRIBE, ENGRAVE, OR MECHANICALLY STAMP (NO DYES OR INKS) A UNIQUE THREE DIGIT SERIAL NUMBER & REVISION NUMBER ON EACH PART. SERIAL NUMBERS START AT 001 FOR THE FIRST ARTICLE AND PROCEED CONSECUTIVELY. BAG AND TAG PARTS WITH THEIR DRAWING PART NUMBER, REVISION, VARIANT OR "TYPE" (IF APPLICABLE), AND QUANTITY. IF PARTS ARE TOO SMALL TO SCRIBE, BAGGING AND TAGGING ALONE IS SUFFICIENT.
EXAMPLE (PART): 001-v1
EXAMPLE (TAG): DXXXXXX-YY, TYPE-XX, QTY: TBD
- 6. MACHINE ALL SURFACES TO REMOVE OXIDES AND MILL FINISH. USE OF ABRASIVE REMOVAL TECHNIQUES IS NOT ALLOWED.
- 7. ALL PARTS SHALL BE MANUFACTURED IN ACCORDANCE WITH LIGO SPECIFICATION E0900364.
- 8. DO NOT REMOVE SHARP EDGES WHERE INDICATED.

REV.	DATE	DCN #	DRAWING TREE #
v1	26 MAY 2009	E0900160	E080191
v2	28 JUN 2010	E1000236	E080191
v3	01 JAN 2011	E1100001	E080191

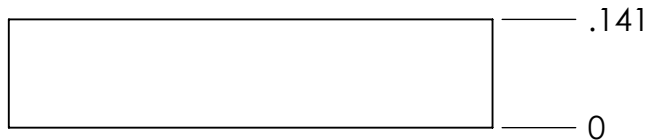
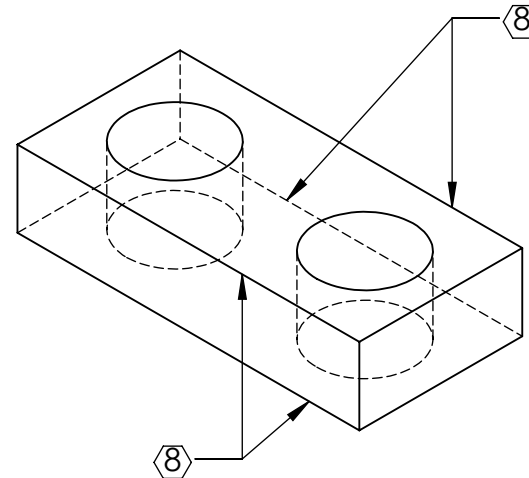
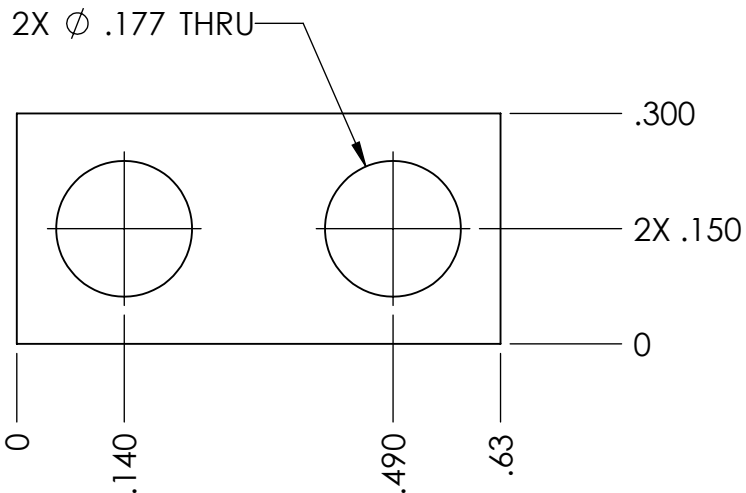

NOTES AND TOLERANCES: (UNLESS OTHERWISE SPECIFIED)

DIMENSIONS ARE IN INCHES

TOLERANCES:
.XX ± .01
.XXX ± .005

ANGULAR ± 0.5°

- 1. INTERPRET DRAWING PER ASME Y14.5-1994.
- 2. REMOVE ALL SHARP EDGES, R.02 MIN.
- 3. DO NOT SCALE FROM DRAWING.
- 4. ALL MACHINING FLUIDS MUST BE FULLY SYNTHETIC, FULLY WATER SOLUBLE AND FREE OF SULFUR, SILICONE, AND CHLORINE.

MATERIAL 304, 316 OR 302 SSSL FINISH 63 μinch

LIGO CALIFORNIA INSTITUTE OF TECHNOLOGY
MASSACHUSETTS INSTITUTE OF TECHNOLOGY

SYSTEM ADVANCED LIGO SUB-SYSTEM SUS NEXT ASSY UPPER WIRE ASSEMBLY

PART NAME LOWER CLAMP, UPPER WIRE, INSIDE

DESIGNER	B. KIRSNER	05 MAR 2008	SIZE	DWG. NO.	REV.
DRAFTER	D. BRIDGES	05 JAN 2011	A	D020610	v3
CHECKER	J. ROMIE	05 JAN 2011	SCALE: 4:1	PROJECTION:	SHEET 1 OF 1
APPROVAL					