

4

3

2

1

NOTES CONTINUED:

- ⑤ SCRIBE, ENGRAVE, OR MECHANICALLY STAMP (NO INKS OR DYES) DRAWING PART NUMBER AND REVISION ON NOTED SURFACE FOLLOWED ON THE NEXT LINE BY A THREE DIGIT SERIAL NUMBER. SERIAL NUMBERS START AT 001 FOR THE FIRST ARTICLE AND PROCEED CONSECUTIVELY. USE .07" HIGH CHARACTERS. EXAMPLE: DXXXXXX-VY, S/N 001. A VIBRATORY TOOL MAY BE USED.
- ⑥ SCRIBE, ENGRAVE, OR MECHANICALLY STAMP (NO INKS OR DYES) MARKING AS SHOWN. A VIBRATORY TOOL MAY BE USED.

REV.	DATE	DCN #	DRAWING TREE #
v1	19 MAY 2009	E0900155	E080191
-	-	-	-
-	-	-	-

2X Ø .266 DRILL THRU

⊕	.010	A	B	C
---	------	---	---	---

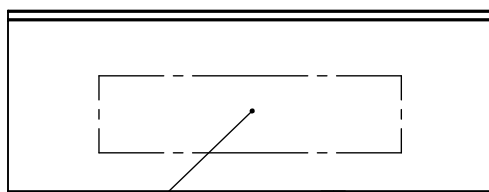
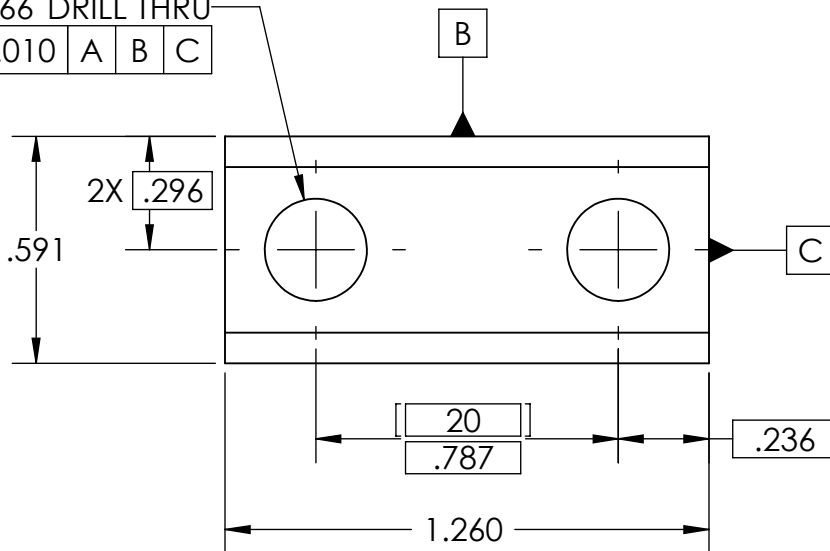

5

A

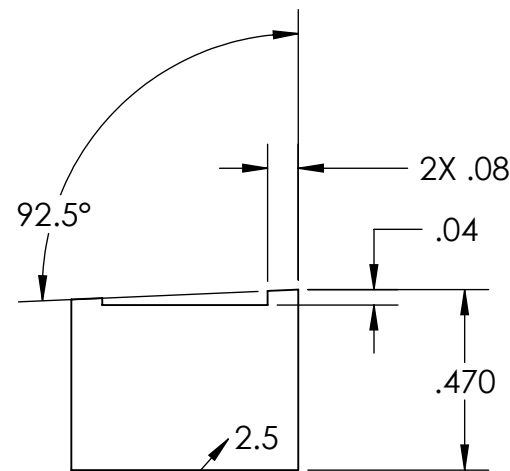
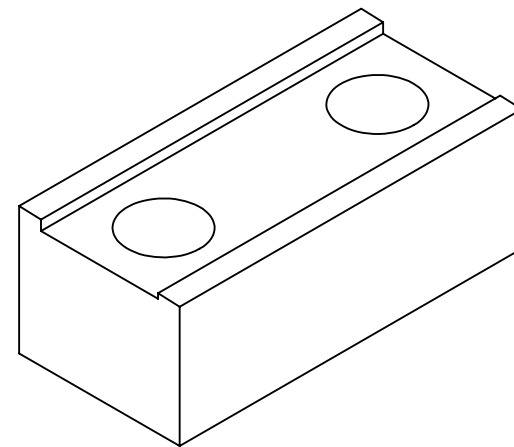

BOTH SIDES

6

NOTES AND TOLERANCES: (UNLESS OTHERWISE SPECIFIED)

DIMENSIONS ARE IN INCHES [MM]

TOLERANCES:
.XX ± .01
.XXX ± .001

ANGULAR ± 0.1°

1. INTERPRET DRAWING PER ASME Y14.5-1994.
2. REMOVE ALL SHARP EDGES, R.02 MIN.
3. DO NOT SCALE FROM DRAWING.
4. ALL MACHINING FLUIDS SHALL BE WATER SOLUBLE AND FREE OF SULFUR, CHLORINE AND SILICONE, SUCH AS CINCINNATI MILACRON'S CIMTECH 410.

MATERIAL 304, 316 OR 302 SSSL

FINISH 32 μinch



SYSTEM ADVANCED LIGO

SUB-SYSTEM SUS

NEXT ASSY LIBRARY OF CLAMPS, LOWER BLADE

PART NAME BLADE CLAMP (2.5 DEGREE), LOWER BLADE, INSIDE

DESIGNER D. BRIDGES 22 APR 2009
 DRAFTER D. BRIDGES 24 APR 2009
 CHECKER M. MEYER 24 APR 2009

SIZE DWG. NO. A D0900686

REV. v1

SCALE: 2:1 PROJECTION: SHEET 1 OF 1

4

3

2

1