

NOTES CONTINUED:

- ⑤ SCRIBE, ENGRAVE, OR MECHANICALLY STAMP (NO INKS OR DYES) DRAWING PART NUMBER AND REVISION ON NOTED SURFACE FOLLOWED ON THE NEXT LINE BY A THREE DIGIT SERIAL NUMBER. SERIAL NUMBERS START AT 001 FOR THE FIRST ARTICLE AND PROCEED CONSECUTIVELY. USE .07" HIGH CHARACTERS. EXAMPLE: DXXXXXX-VY, S/N 001. A VIBRATORY TOOL MAY BE USED.
- ⑥ SCRIBE, ENGRAVE, OR MECHANICALLY STAMP (NO INKS OR DYES) MARKING AS SHOWN. A VIBRATORY TOOL MAY BE USED.

REV.	DATE	DCN #	DRAWING TREE #
v1	19 MAY 2009	E0900154	E080191
-	-	-	-
-	-	-	-

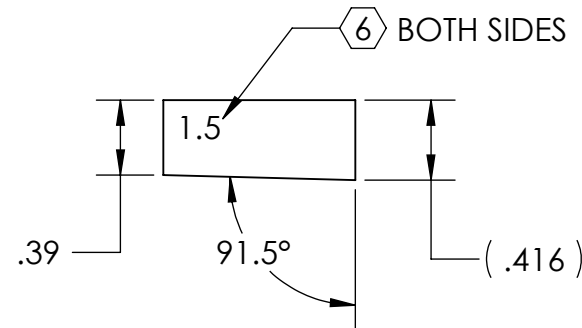
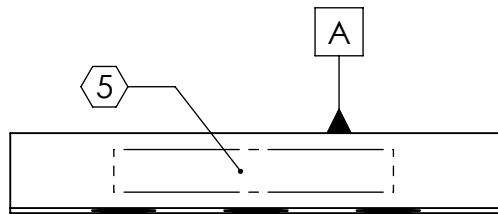
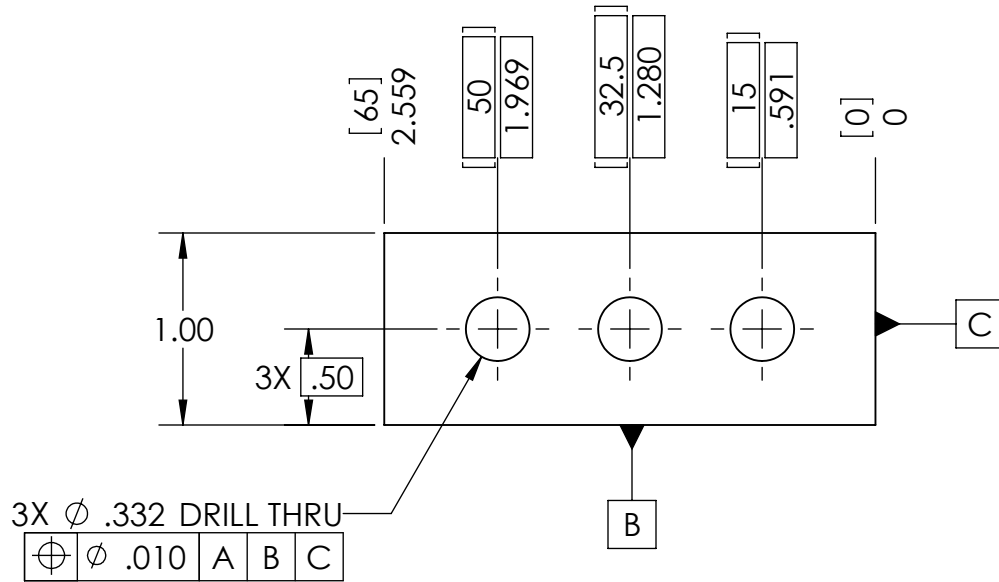
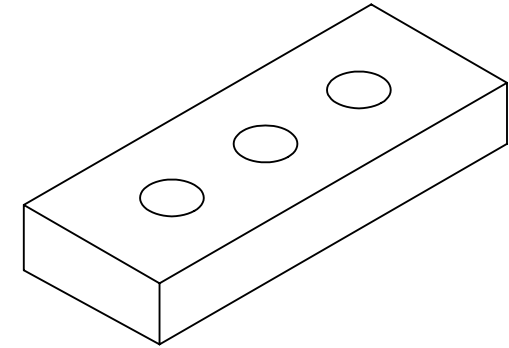

NOTES AND TOLERANCES: (UNLESS OTHERWISE SPECIFIED)

DIMENSIONS ARE IN INCHES [MM]	1. INTERPRET DRAWING PER ASME Y14.5-1994. 2. REMOVE ALL SHARP EDGES, R.02 MIN. 3. DO NOT SCALE FROM DRAWING. 4. ALL MACHINING FLUIDS SHALL BE WATER SOLUBLE AND FREE OF SULFUR, CHLORINE AND SILICONE, SUCH AS CINCINNATI MILACRON'S CIMTECH 410.
TOLERANCES: .XX \pm .01 .XXX \pm .005	MATERIAL 304, 316 OR 302 SSSL
ANGULAR \pm 0.1°	FINISH 32 μ inch

LIGO CALIFORNIA INSTITUTE OF TECHNOLOGY
MASSACHUSETTS INSTITUTE OF TECHNOLOGY

SYSTEM
ADVANCED LIGO

SUB-SYSTEM
SUS

NEXT ASSY
LIBRARY OF CLAMPS, UPPER BLADE

PART NAME BLADE CLAMP (1.5 DEGREE), UPPER BLADE, OUTSIDE		DESIGNER D. BRIDGES	21 APR 2009	SIZE A	DWG. NO. D0900676	REV. v1
CHECKER M. MEYER	22 APR 2009	APPROVAL	SCALE: 1:1	PROJECTION:	SHEET 1 OF 1	