

NOTES CONTINUED:

- ⑤ SCRIBE, ENGRAVE, OR MECHANICALLY STAMP (NO INKS OR DYES) DRAWING PART NUMBER AND REVISION ON NOTED SURFACE FOLLOWED ON THE NEXT LINE BY A THREE DIGIT SERIAL NUMBER. SERIAL NUMBERS START AT 001 FOR THE FIRST ARTICLE AND PROCEED CONSECUTIVELY. USE .07" HIGH CHARACTERS. EXAMPLE: DXXXXXX-VY, S/N 001. A VIBRATORY TOOL MAY BE USED.
- ⑥ SCRIBE, ENGRAVE, OR MECHANICALLY STAMP (NO INKS OR DYES) MARKING AS SHOWN. A VIBRATORY TOOL MAY BE USED.

REV.	DATE	DCN #	DRAWING TREE #
v1	19 MAY 2009	E0900154	E080191
-	-	-	-
-	-	-	-

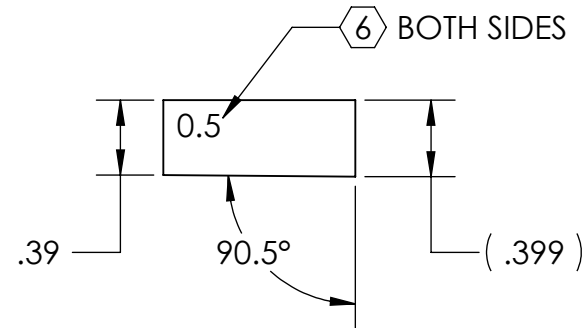
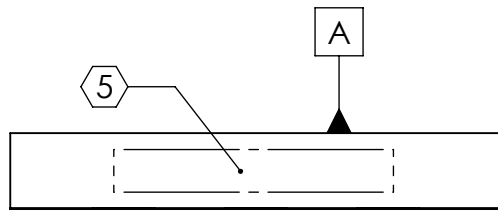
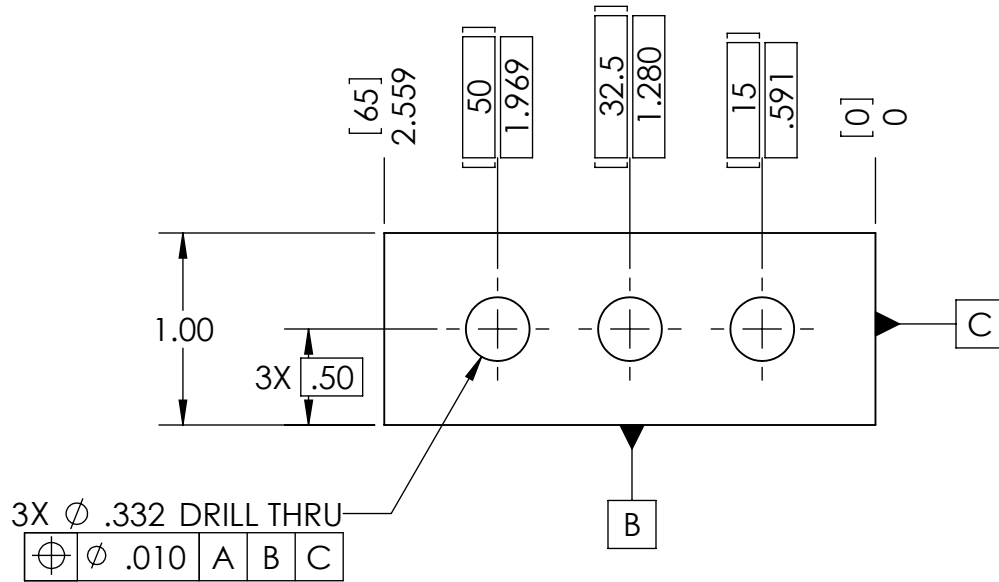
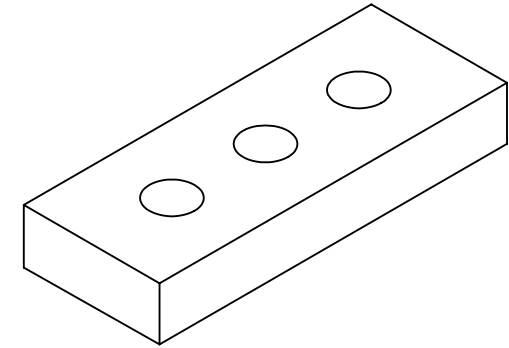

NOTES AND TOLERANCES: (UNLESS OTHERWISE SPECIFIED)

DIMENSIONS ARE IN INCHES [MM]	1. INTERPRET DRAWING PER ASME Y14.5-1994. 2. REMOVE ALL SHARP EDGES, R.02 MIN. 3. DO NOT SCALE FROM DRAWING. 4. ALL MACHINING FLUIDS SHALL BE WATER SOLUBLE AND FREE OF SULFUR, CHLORINE AND SILICONE, SUCH AS CINCINNATI MILACRON'S CIMTECH 410.
TOLERANCES: .XX ± .01 .XXX ± .005	
ANGULAR ± 0.1°	
MATERIAL 304, 316 OR 302 SSSL	FINISH 32 μinch

LIGO CALIFORNIA INSTITUTE OF TECHNOLOGY
MASSACHUSETTS INSTITUTE OF TECHNOLOGY

SYSTEM: **ADVANCED LIGO** SUB-SYSTEM: **SUS**

NEXT ASSY: **LIBRARY OF CLAMPS, UPPER BLADE**

PART NAME BLADE CLAMP (0.5 DEGREE), UPPER BLADE, OUTSIDE	
DESIGNER D. BRIDGES	21 APR 2009
DRAFTER D. BRIDGES	22 APR 2009
CHECKER M. MEYER	22 APR 2009
APPROVAL	
SIZE A	DWG. NO. D0900674
SCALE: 1:1	PROJECTION:
REV. v1	SHEET 1 OF 1