

NOTES CONTINUED:

- ⑤ SCRIBE, ENGRAVE, OR MECHANICALLY STAMP (NO INKS OR DYES) DRAWING PART NUMBER AND REVISION ON NOTED SURFACE FOLLOWED ON THE NEXT LINE BY A THREE DIGIT SERIAL NUMBER. SERIAL NUMBERS START AT 001 FOR THE FIRST ARTICLE AND PROCEED CONSECUTIVELY. USE .07" HIGH CHARACTERS. EXAMPLE: DXXXXXX-VY, S/N 001. A VIBRATORY TOOL MAY BE USED.
- ⑥ SCRIBE, ENGRAVE, OR MECHANICALLY STAMP (NO INKS OR DYES) MARKING AS SHOWN. A VIBRATORY TOOL MAY BE USED.

REV.	DATE	DCN #	DRAWING TREE #
v1	19 MAY 2009	E0900154	E080191
-	-	-	-
-	-	-	-

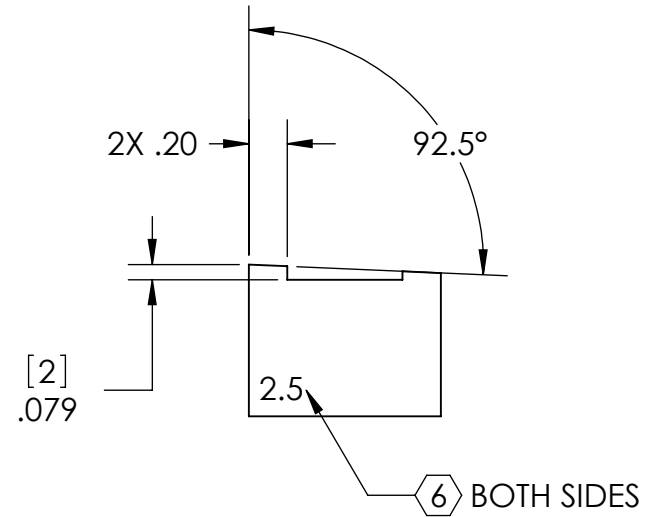
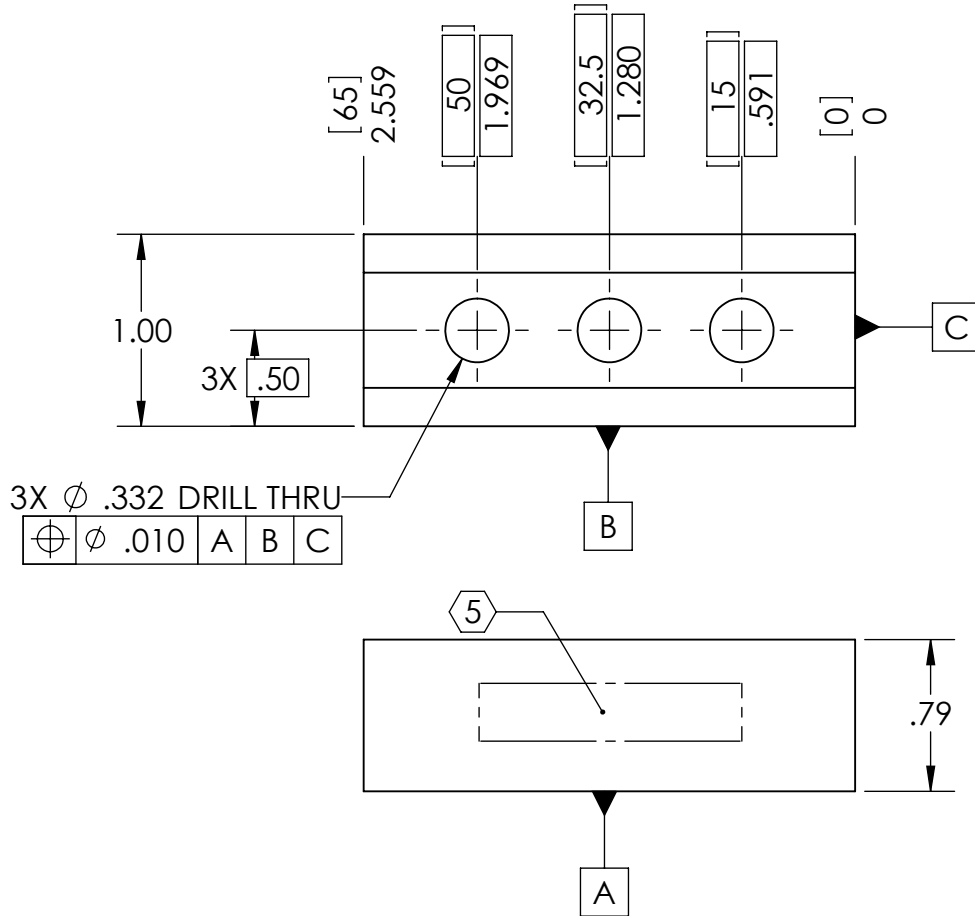
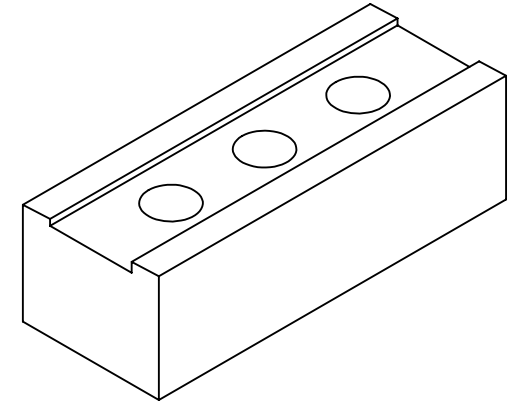

NOTES AND TOLERANCES: (UNLESS OTHERWISE SPECIFIED)

DIMENSIONS ARE IN INCHES [MM]	1. INTERPRET DRAWING PER ASME Y14.5-1994. 2. REMOVE ALL SHARP EDGES, R.02 MIN. 3. DO NOT SCALE FROM DRAWING. 4. ALL MACHINING FLUIDS SHALL BE WATER SOLUBLE AND FREE OF SULFUR, CHLORINE AND SILICONE, SUCH AS CINCINNATI MILACRON'S CIMTECH 410.
TOLERANCES: .XX ± .01 .XXX ± .005	
ANGULAR ± 0.1°	
MATERIAL 304, 316 OR 302 SSSL	FINISH 32 $\mu$ inch

CALIFORNIA INSTITUTE OF TECHNOLOGY MASSACHUSETTS INSTITUTE OF TECHNOLOGY	PART NAME BLADE CLAMP (2.5 DEGREE), UPPER BLADE, INSIDE	
	SYSTEM ADVANCED LIGO	SUB-SYSTEM SUS
NEXT ASSY LIBRARY OF CLAMPS, UPPER BLADE	DESIGNER D. BRIDGES	20 APR 2009
	DRAFTER D. BRIDGES	21 APR 2009
	CHECKER M. MEYER	21 APR 2009
	APPROVAL	

SIZE A	DWG. NO. D0900671	REV. v1
SCALE: 1:1	PROJECTION:	SHEET 1 OF 1