

NOTES CONTINUED:

- ⑤ SCRIBE, ENGRAVE, OR MECHANICALLY STAMP (NO INKS OR DYES) DRAWING PART NUMBER, REVISION (AND VARIANT OR "TYPE" IF APPLICABLE) ON NOTED SURFACE OF PART FOLLOWED ON THE NEXT LINE WITH A THREE DIGIT SERIAL NUMBER. SERIAL NUMBERS START AT 001 FOR THE FIRST ARTICLE AND PROCEED CONSECUTIVELY. USE MINIMUM 0.12" HIGH CHARACTERS, UNLESS THE SIZE OF THE PART DICTATES SMALLER CHARACTERS. A VIBRATORY TOOL MAY BE USED.
EXAMPLE: DXXXXXX-VY, TYPE-XX, S/N XXX
- 6. MACHINE ALL SURFACES TO REMOVE OXIDES AND MILL FINISH. USE OF ABRASIVE REMOVAL TECHNIQUES IS NOT ALLOWED.
- 7. ALL PARTS SHALL BE MANUFACTURED IN ACCORDANCE WITH LIGO SPECIFICATION E0900364.
- ⑥ SCRIBE, ENGRAVE, OR MECHANICALLY STAMP (NO INKS OR DYES) AS MARKED ON NOTED SURFACE OF PART. USE .12" HIGH CHARACTERS.
- ⑦ DO NOT REMOVE SHARP EDGES.

REV.	DATE	DCN #	DRAWING TREE #
v1	19 MAY 2009	E0900154	E080191
v2	18 MAY 2010	E1000166	E080191
-	-	-	-

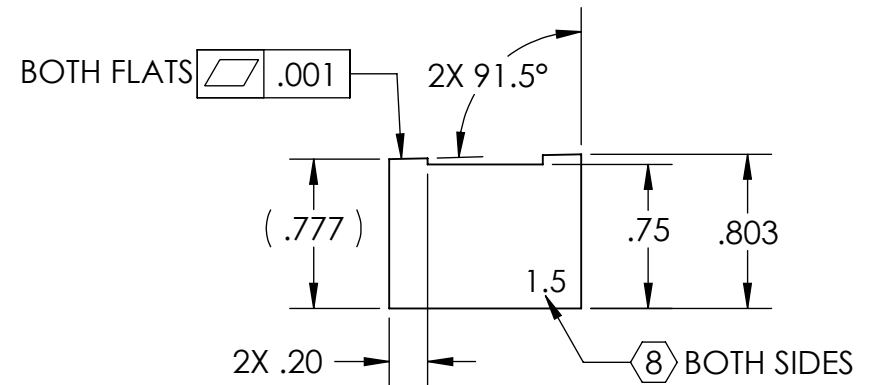
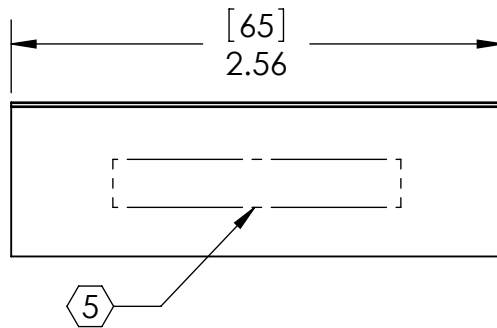
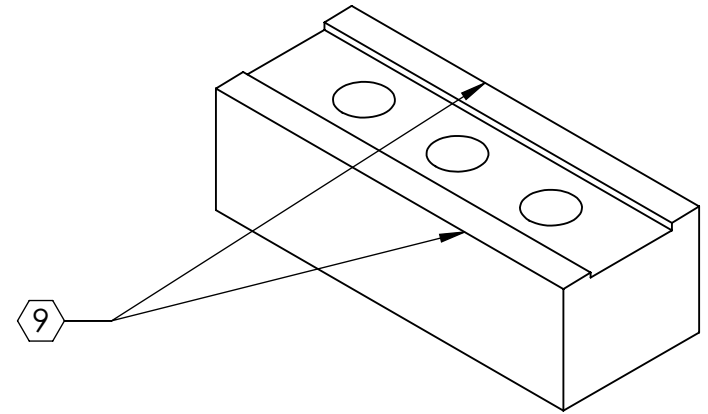
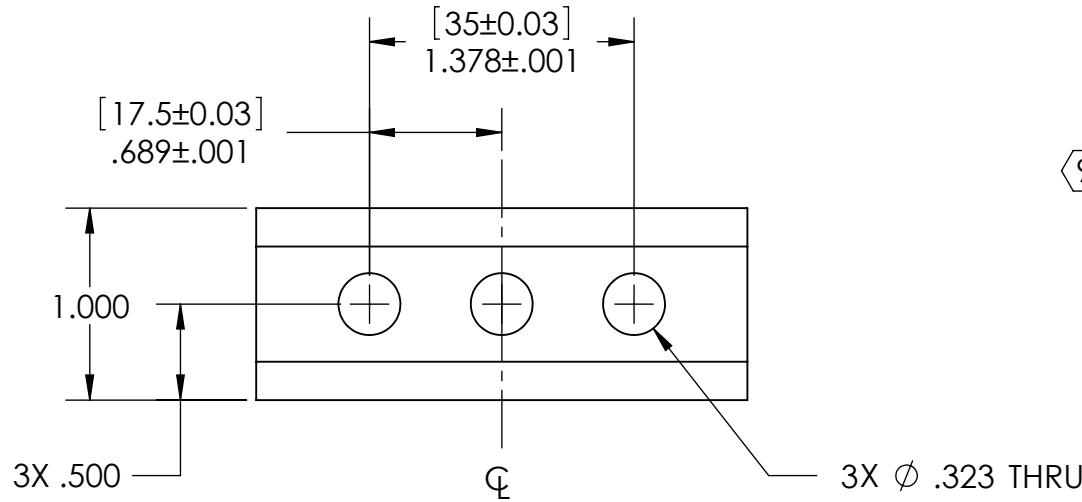

NOTES AND TOLERANCES: (UNLESS OTHERWISE SPECIFIED)

DIMENSIONS ARE IN INCHES [MM]
 TOLERANCES:
 .XX ± .01
 .XXX ± .005
 ANGULAR ± 0.1°

1. INTERPRET DRAWING PER ASME Y14.5-1994.
 2. REMOVE ALL SHARP EDGES, R.02 MIN.
 3. DO NOT SCALE FROM DRAWING.
 4. ALL MACHINING FLUIDS SHALL BE WATER SOLUBLE AND FREE OF SULFUR, CHLORINE AND SILICONE, SUCH AS CINCINNATI MILACRON'S CIMTECH 410.

MATERIAL 304, 316 OR 302 SSSL
FINISH 32 μ inch

LIGO CALIFORNIA INSTITUTE OF TECHNOLOGY
 MASSACHUSETTS INSTITUTE OF TECHNOLOGY

SYSTEM ADVANCED LIGO
SUB-SYSTEM SUS

NEXT ASSY LIBRARY OF CLAMPS, UPPER BLADE

PART NAME BLADE CLAMP (1.5 DEGREE), UPPER BLADE, INSIDE

DESIGNER D. BRIDGES 29 JUN 2010
DRAFTER D. BRIDGES 29 JUN 2010
CHECKER M. MEYER 30 JUN 2010

SIZE DWG. NO. **D0900669**
SCALE 1:1
PROJECTION SHEET 1 OF 1

REV. v2