

**NOTES CONTINUED:**

- ⑤ SCRIBE, ENGRAVE, OR MECHANICALLY STAMP (NO INKS OR DYES) DRAWING PART NUMBER, REVISION (AND VARIANT OR "TYPE" IF APPLICABLE) ON NOTED SURFACE OF PART FOLLOWED ON THE NEXT LINE WITH A THREE DIGIT SERIAL NUMBER. SERIAL NUMBERS START AT 001 FOR THE FIRST ARTICLE AND PROCEED CONSECUTIVELY. USE MINIMUM 0.12" HIGH CHARACTERS, UNLESS THE SIZE OF THE PART DICTATES SMALLER CHARACTERS. A VIBRATORY TOOL MAY BE USED.  
EXAMPLE: DXXXXXX-VY, TYPE-XX; S/N XXX
- 6. MACHINE ALL SURFACES TO REMOVE OXIDES AND MILL FINISH. USE OF ABRASIVE REMOVAL TECHNIQUES IS NOT ALLOWED.
- 7. ALL PARTS SHALL BE MANUFACTURED IN ACCORDANCE WITH LIGO SPECIFICATION E0900364.
- ⑥ SCRIBE, ENGRAVE, OR MECHANICALLY STAMP (NO INKS OR DYES) AS MARKED ON NOTED SURFACE OF PART. USE .12" HIGH CHARACTERS.
- ⑦ DO NOT REMOVE SHARP EDGES.

REV.	DATE	DCN #	DRAWING TREE #
v1	19 MAY 2009	E0900154	E080191
v2	18 MAY 2010	E1000166	E080191
v3	21 NOV 2010	E1000741	E080191

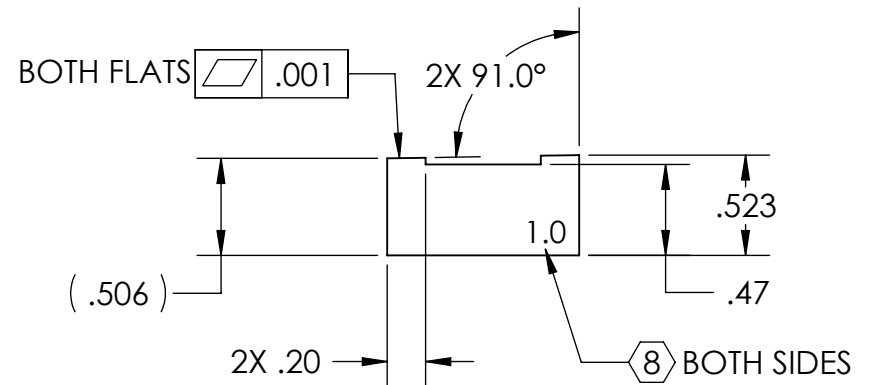
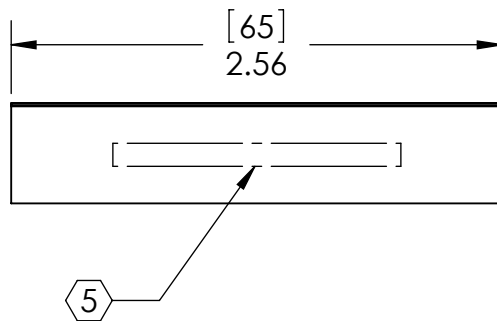
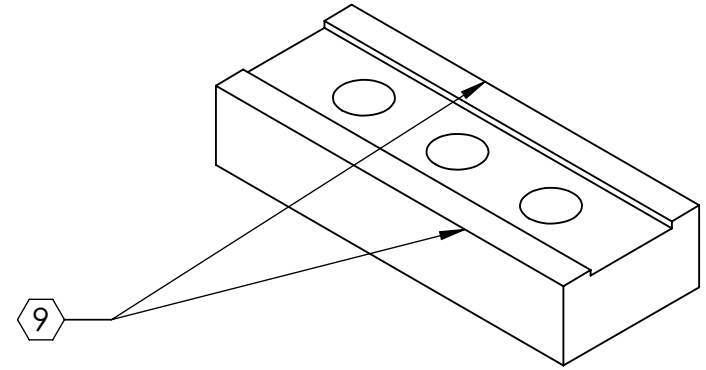
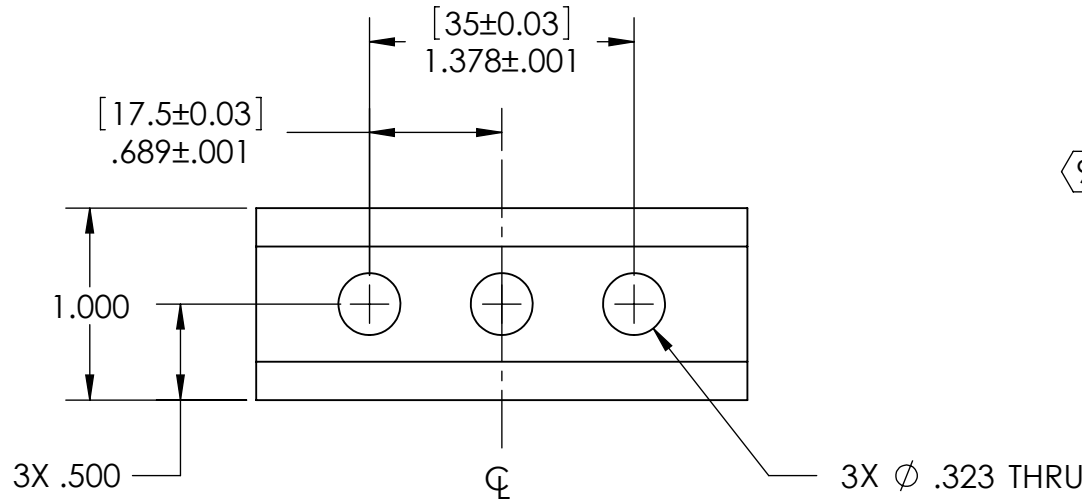

**NOTES AND TOLERANCES: (UNLESS OTHERWISE SPECIFIED)**

DIMENSIONS ARE IN INCHES [MM]  
 TOLERANCES:  
 .XX ± .01  
 .XXX ± .005  
 ANGULAR ± 0.1°

1. INTERPRET DRAWING PER ASME Y14.5-1994.  
 2. REMOVE ALL SHARP EDGES, R.02 MIN.  
 3. DO NOT SCALE FROM DRAWING.  
 4. ALL MACHINING FLUIDS SHALL BE WATER SOLUBLE AND FREE OF SULFUR, CHLORINE AND SILICONE, SUCH AS CINCINNATI MILACRON'S CIMTECH 410.

**MATERIAL** 304, 316 OR 302 SSTL  
**FINISH** 63 μinch

**LIGO** CALIFORNIA INSTITUTE OF TECHNOLOGY  
 MASSACHUSETTS INSTITUTE OF TECHNOLOGY

**SYSTEM** ADVANCED LIGO  
**SUB-SYSTEM** SUS

**NEXT ASSY** LIBRARY OF CLAMPS, UPPER BLADE

**PART NAME** BLADE CLAMP (1.0 DEGREE), UPPER BLADE, INSIDE

**DESIGNER** D. BRIDGES 20 NOV 2010  
**DRAFTER** D. BRIDGES 21 NOV 2010  
**CHECKER** M. MEYER 22 NOV 2010  
**APPROVAL**

**SIZE** DWG. NO. **D0900668**  
**REV.** v3

**SCALE:** 1:1 **PROJECTION:** **SHEET 1 OF 1**