

D0900626_Advanced_LIGO_SUS_HLTS_Mounting_Pad_Assembly, PART PDM REV: X-006, DRAWING PDM REV: X-001

REV.	DATE	DCN #	DRAWING TREE #
V1	3 MAR 2009	E0900066	E080191
-	-	-	-
-	-	-	-

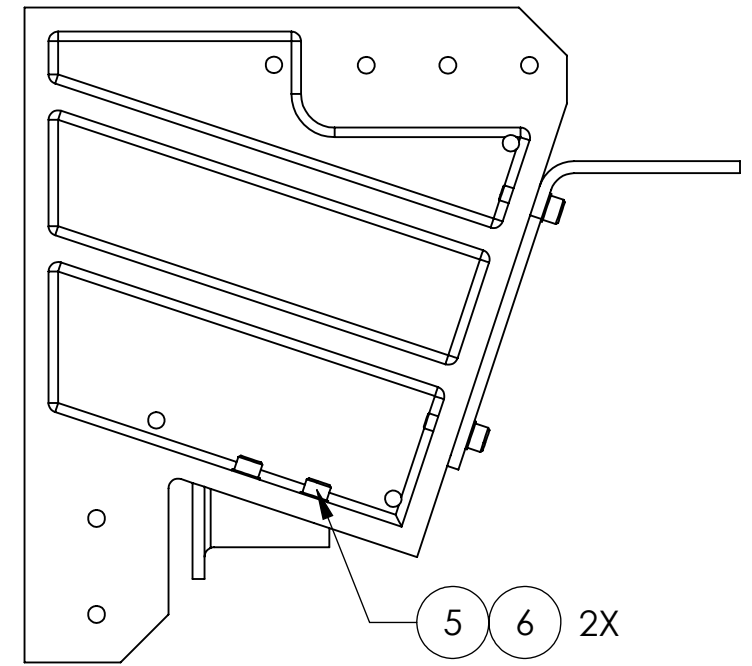
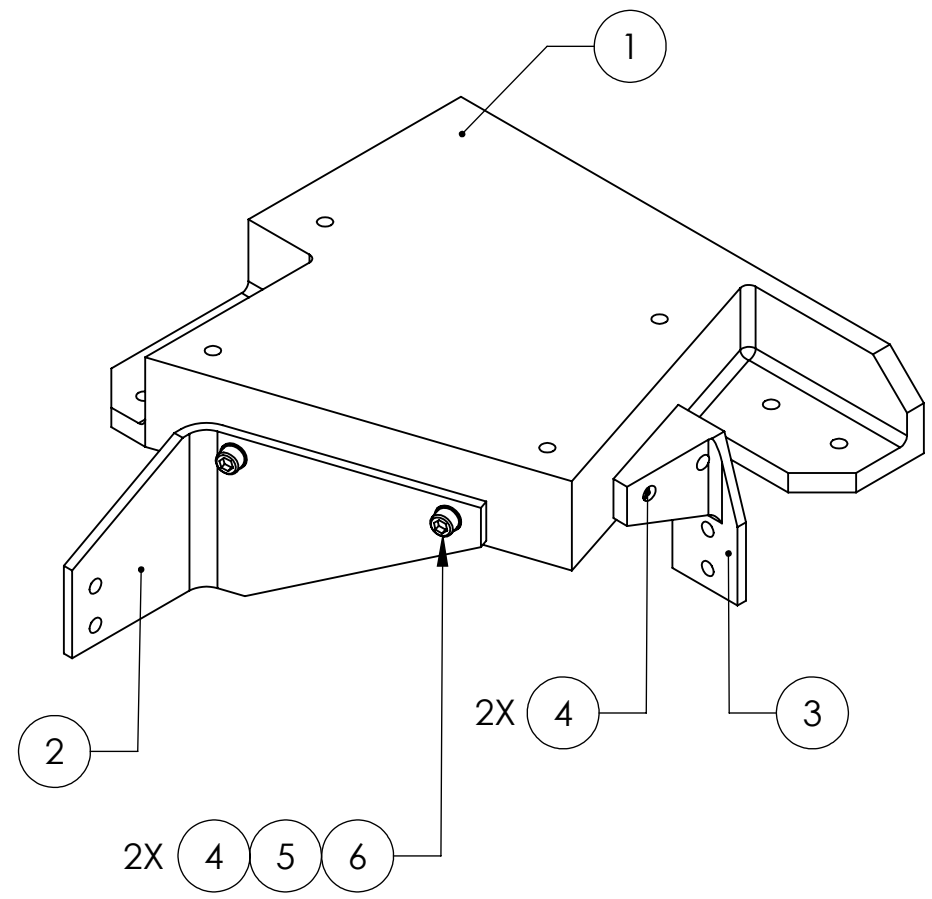

ITEM NO.	REQ	SPARE	TOTAL	PART NUMBER	DESCRIPTION	MATERIAL
6	4	1	5	-	WASHER, FLAT, #8 (NAS 620-C8L OR EQUIVALENT)	300 SSSL
5	4	1	5	-	SCREW, SOCKET HEAD CAP, #8-32 UNC-2A X 0.5 LONG	300 SSSL
4	4	2	6	1185-2EN246	HELICOIL, #8-32 X 0.246 LONG	NITRONIC 60
3	1	0	1	D0900628	SIDE BRACKET, MOUNTING PAD	6061-T6 Al
2	1	0	1	D0900627	FRONT BRACKET, MOUNTING PAD	6061-T6 Al
1	1	0	1	D070374	MOUNTING PAD BODY	6061-T6 Al

NOTES: (UNLESS OTHERWISE SPECIFIED)
 1. REMOVE ALL SHARP EDGES, R.02 MIN.
 2. DO NOT SCALE FROM DRAWING.

DIMENSIONS ARE IN INCHES
 TOLERANCES:
 .XX ± .01
 .XXX ± .005
 ANGULAR ± 0.1°
 MATERIAL N/A
 FINISH N/A μinch

DESIGNER	D. BRIDGES	9 APR 2009
DRAWN	D. BRIDGES	14 APR 2009
CHECKED	M. MEYER	14 APR 2009

CALIFORNIA INSTITUTE OF TECHNOLOGY
 MASSACHUSETTS INSTITUTE OF TECHNOLOGY
 SYSTEM ADVANCED LIGO
 SUB-SYSTEM SUS
 NEXT ASSY HLTS STRUCTURE
 PART NAME MOUNTING PAD ASSEMBLY
 SIZE DWG. NO. B D0900626 REV. V1
 SCALE: 1:2 PROJECTION: SHEET 1 OF 1