

REV.	DATE	DCN #	DRAWING TREE #
v1	7 OCT 2010	E1000563	-
v2	17 DEC 2010	E1000563	
v3	16 FEB 2011	E1000563	
v4	11 JUN 2011	E1000563	

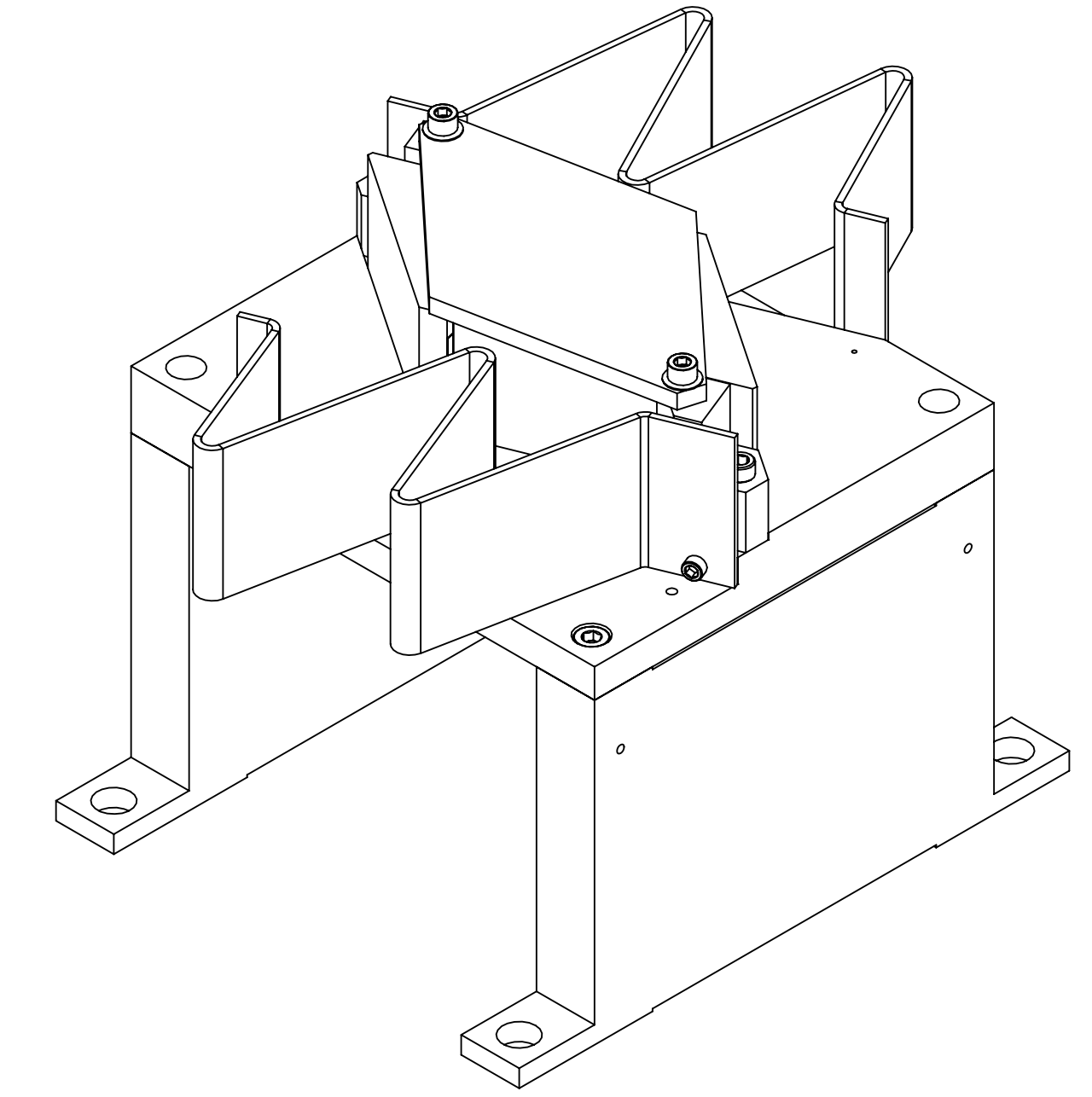
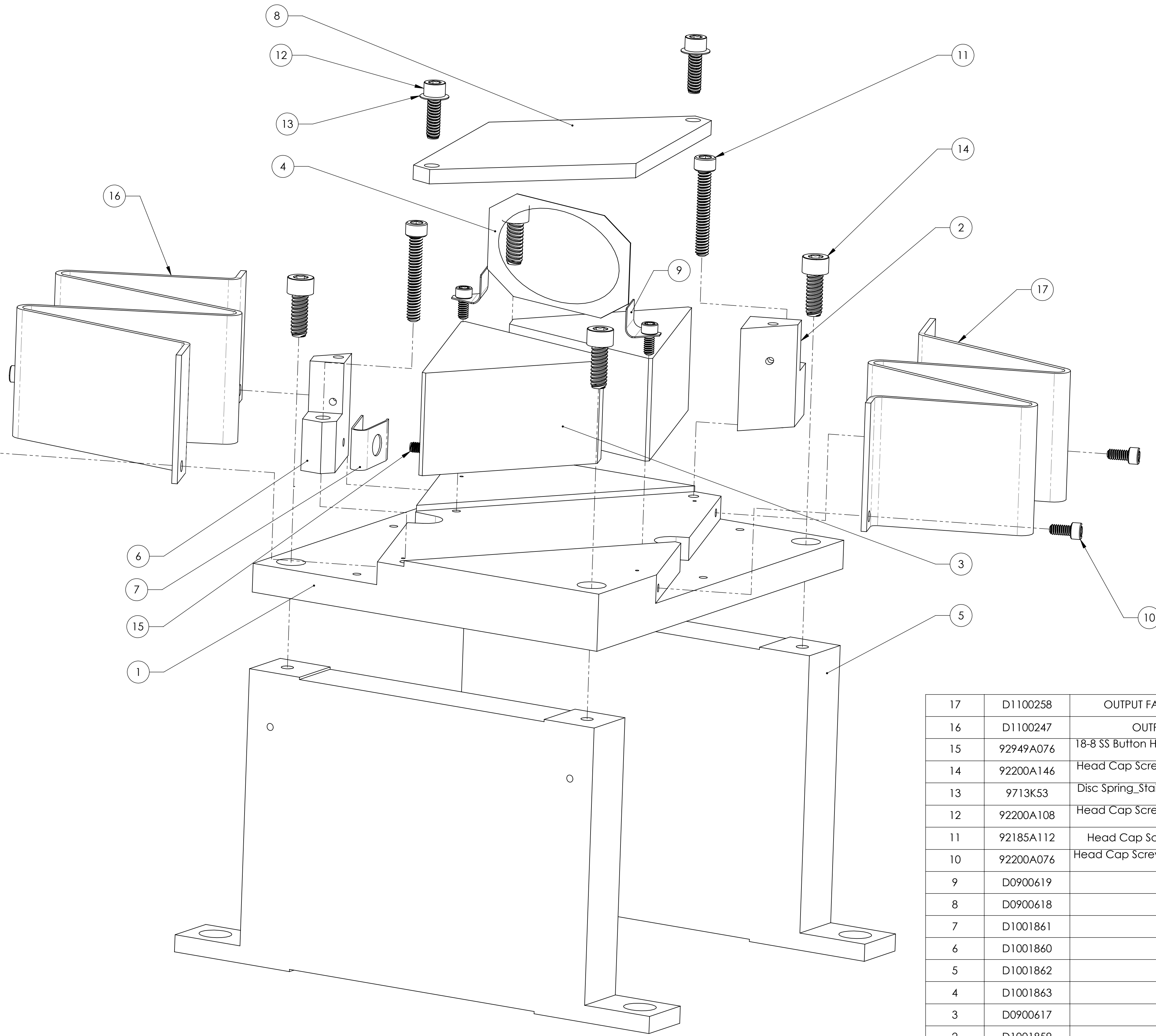
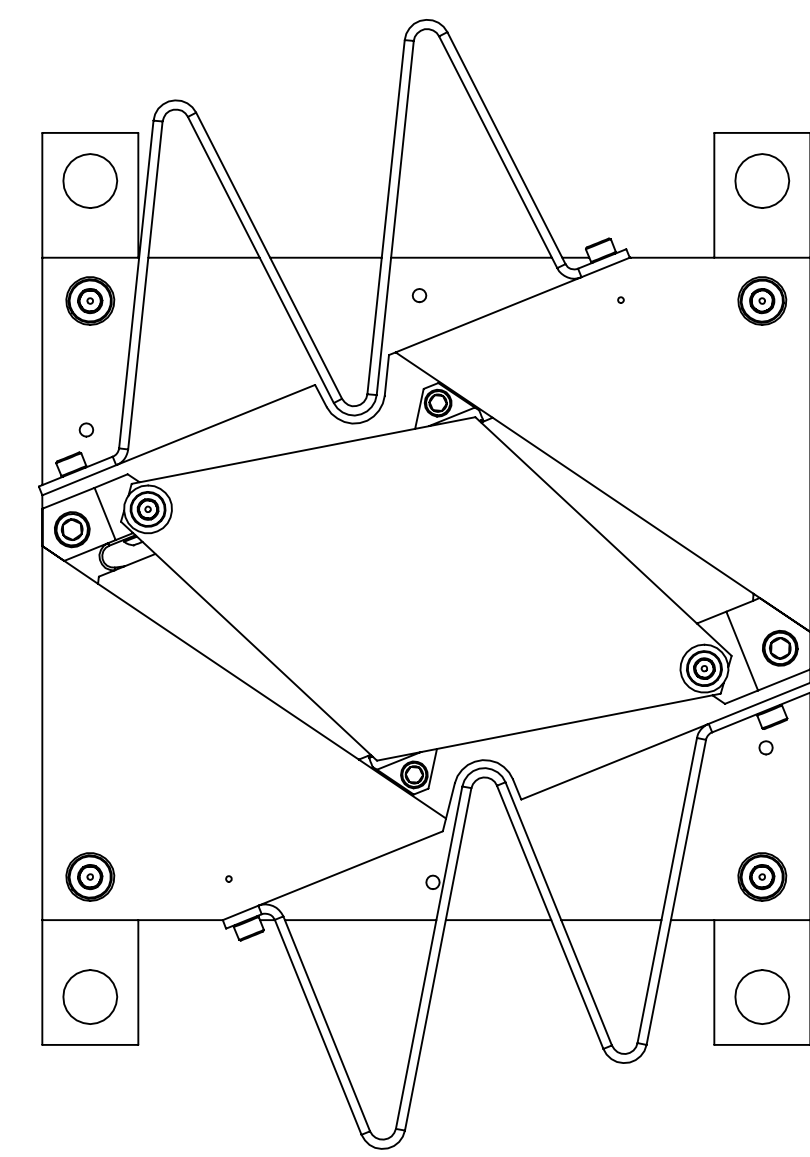

GENERAL VIEW
FOR REFERENCE ONLY
NO SCALE

ITEM NO.	PART NUMBER	DESCRIPTION	MATERIAL	QTY	SPARE	TOTAL
17	D1100258	OUTPUT FARADAY ISOLATOR BAFFLE (opposite)	A424 TYPE I, 18GA, SSSL	1		0
16	D1100247	OUTPUT FARADAY ISOLATOR BAFFLE	A424 TYPE I, 18GA, SSSL	1		0
15	92949A076	18-8 SS Button Head Socket Cap Screw 2-56 Thread, 3/16" Length	18-8 SSSL	1		0
14	92200A146	Head Cap Screw 300 Series SS, 6-32 Thrd, 3/8" Length, MS 16995-17	300 SSSL	4		0
13	9713K53	Disc Spring_Stainless Steel Belleville, .125 ID, .250 OD, .009 Thick	304 SSSL	2		0
12	92200A108	Head Cap Screw 300 Series SS, 4-40 Thrd, 3/8" Length, MS 16995-10	18-8 SSSL	2		0
11	92185A112	Head Cap Screw 300 Series SS, 4-40 Thrd, 3/4" Length	300 SSSL	2		0
10	92200A076	Head Cap Screw 300 Series SS, 2-56 Thrd, 3/16" Length, MS 16995-1	300 SSSL	6		0
9	D0900619	CLIP	304 SSSL	2		0
8	D0900618	OPTICAL PRISM TOP PLATE	6061-T6 Al	1		0
7	D1001861	U-SPRING	304 SSSL	1		0
6	D1001860	SPRING BLOCK_RH	6061-T6 Al	1		0
5	D1001862	PRISM BASE SUPPORT	6061-T6 Al	2		0
4	D1001863	OPTICAL PRISM SPACER	304 SSSL	1		0
3	D0900617	OPTICAL PRISM	CALCITE	2		0
2	D1001859	FIXED STOP_RH	6061-T6 Al	1		0
1	D0900620	PRISM MOUNT BASE_RH	6061-T6 Al	1		0

NOTES AND TOLERANCES: (UNLESS OTHERWISE SPECIFIED)	
1. INTERPRET DRAWING PER ASME Y14.5-1994.	
2. REMOVE ALL SHARP EDGES, R.02 MIN.	
3. DO NOT SCALE FROM DRAWING.	
4. ALL MACHINING FLUIDS MUST BE FULLY SYNTHETIC, FULLY WATER SOLUBLE AND FREE OF SULFUR, SILICONE, AND CHLORINE.	
MATERIAL	N/A
FINISH	N/A μinch

LIGO CALIFORNIA INSTITUTE OF TECHNOLOGY MASSACHUSETTS INSTITUTE OF TECHNOLOGY		PART NAME	
ADVANCED LIGO		PRISM MOUNT ASSY_RH	
DESIGNER	TQ. NGUYEN	19 JUL 2010	SIZE DWG. NO.
DRAFTER	TQ. NGUYEN	23 AUG 2010	D D0900615
CHECKER	M. SMITH		REV. v4
APPROVAL	D. COYNE		SCALE: 1:2 PROJECTION: SHEET 1 OF 1

D0900615.dwg: ACE Prism Mounting Assy_RH PART PDM REV: X.023. DRAWING PDM REV: X.018