

REV.	DATE	DCN #	DRAWING TREE #
v1	22 APR 2013	-	-
v2	16 JUL 2013	-	-
v3	10 DEC 2014	-	-

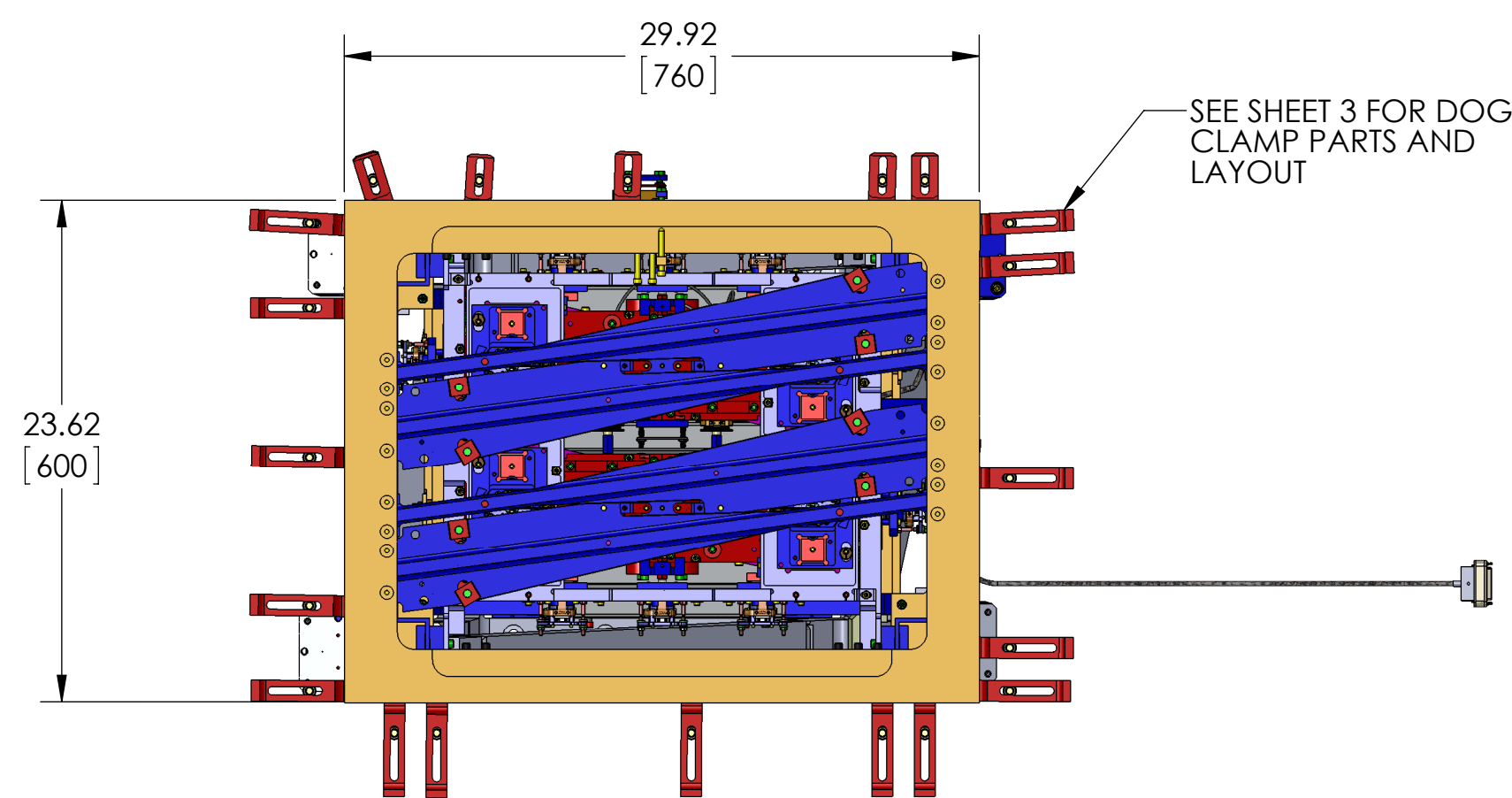

TOP VIEW

FOR QUAD TOOLING DETAILS, REFER TO QUAD MASTER DRAWING D0901346, SHEET 9

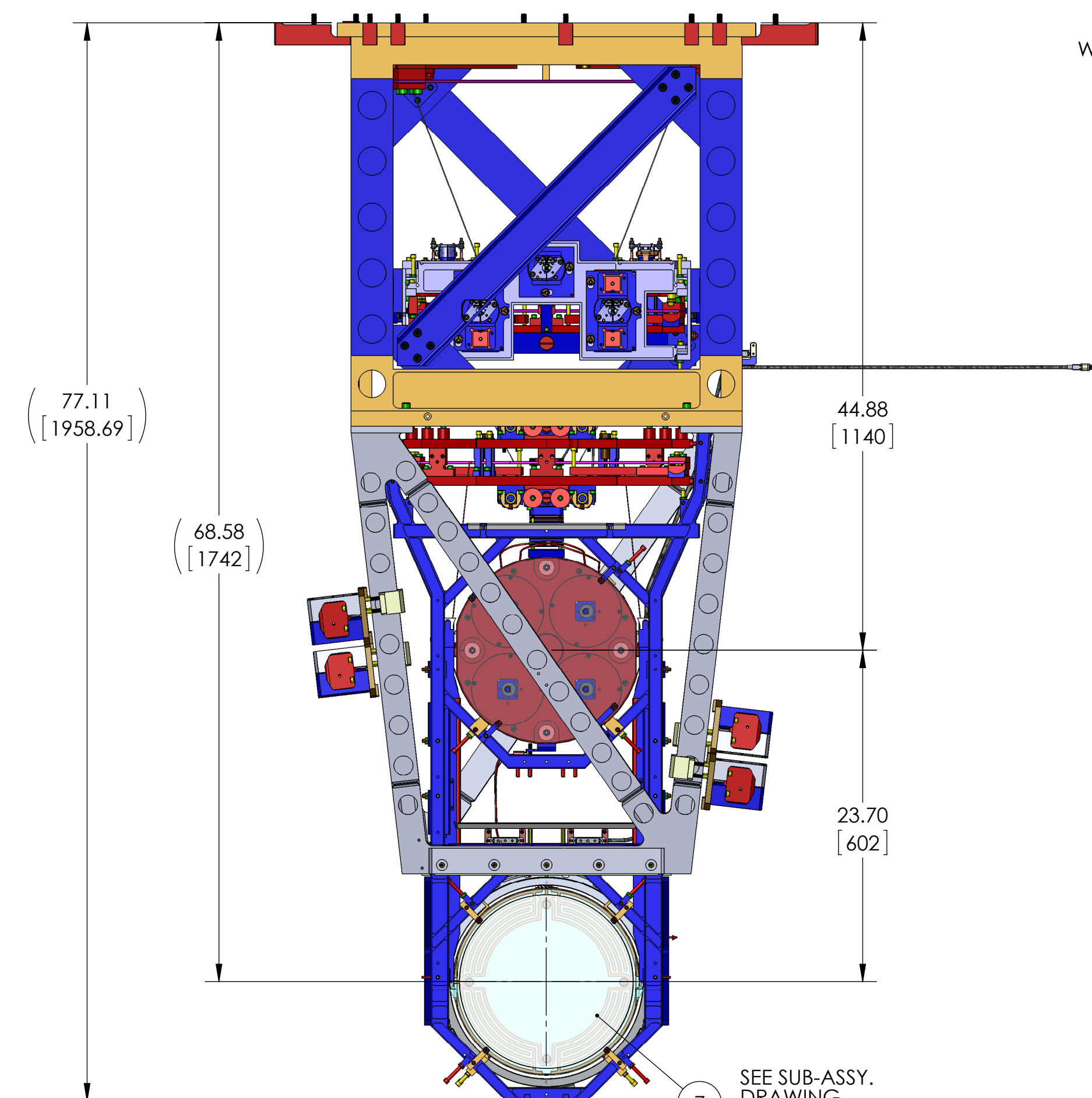

NOTE: RING HEATER SHOULD OPEN AND CLOSE WITHOUT INTERFERENCE. IN CASE OF INTERFERENCE, REMOVE THE INDICATED FASTENER IN DETAIL "E", AND REATTACH AFTER RING HEATER IS CLOSED

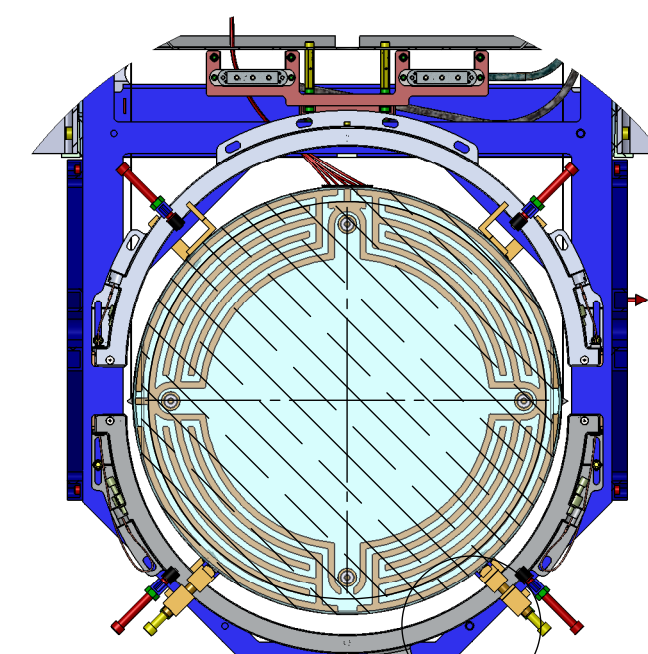

SECTION C-C
(RING HEATER OPEN)
SCALE: ENLARGED

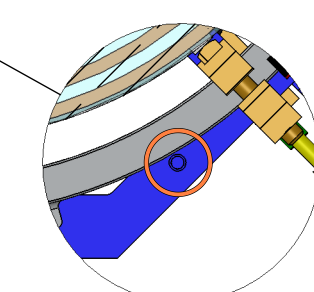

DETAIL D
SCALE 1 : 3

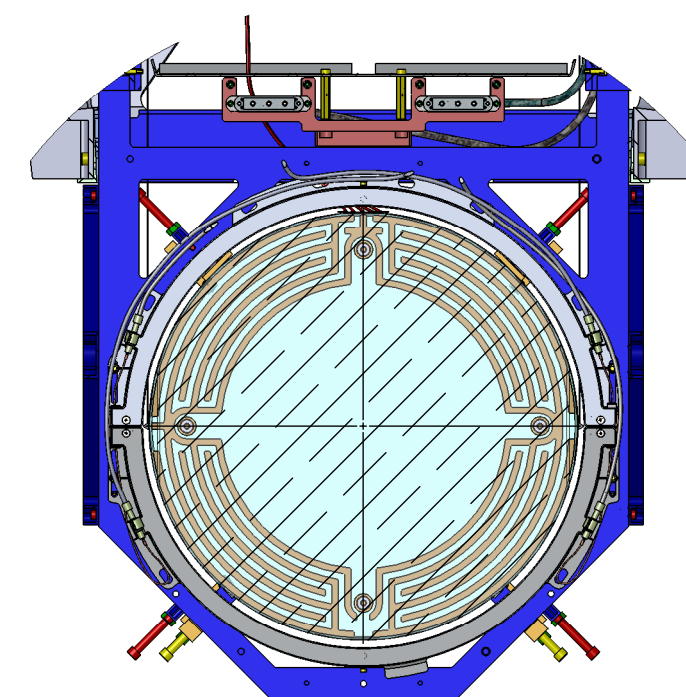

SECTION C-C
(RING HEATER CLOSED)
SCALE: ENLARGED

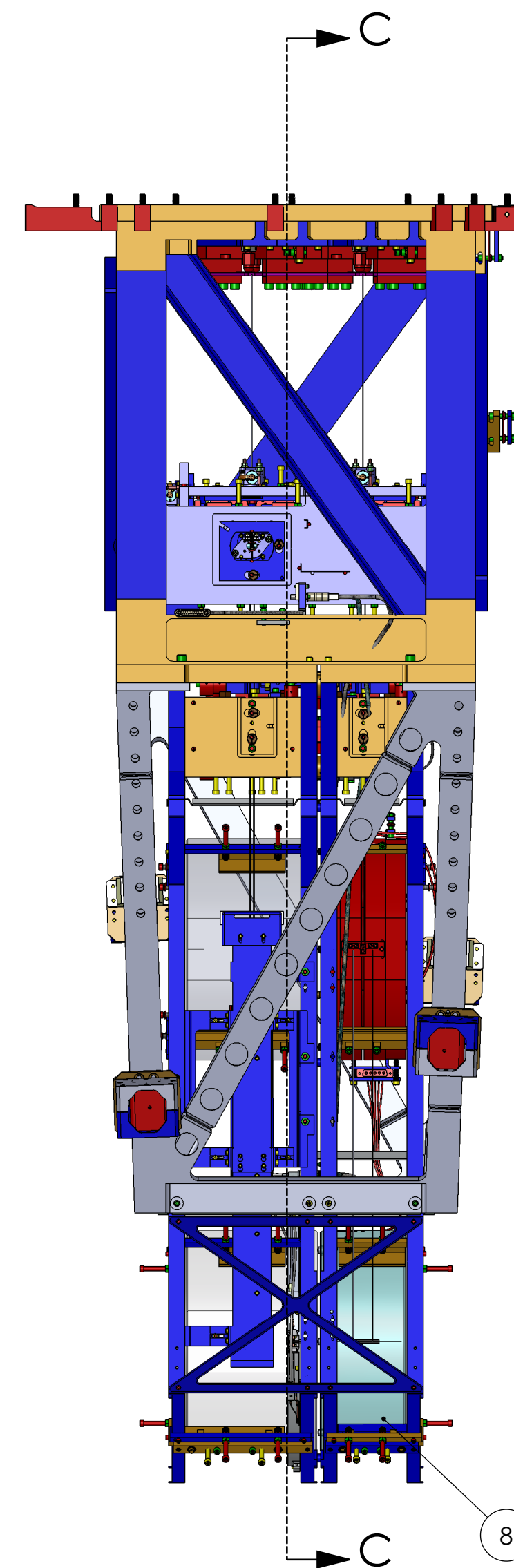

SEE SUB-ASSY. DRAWING FOR OPTIC SERIAL NO. DATA

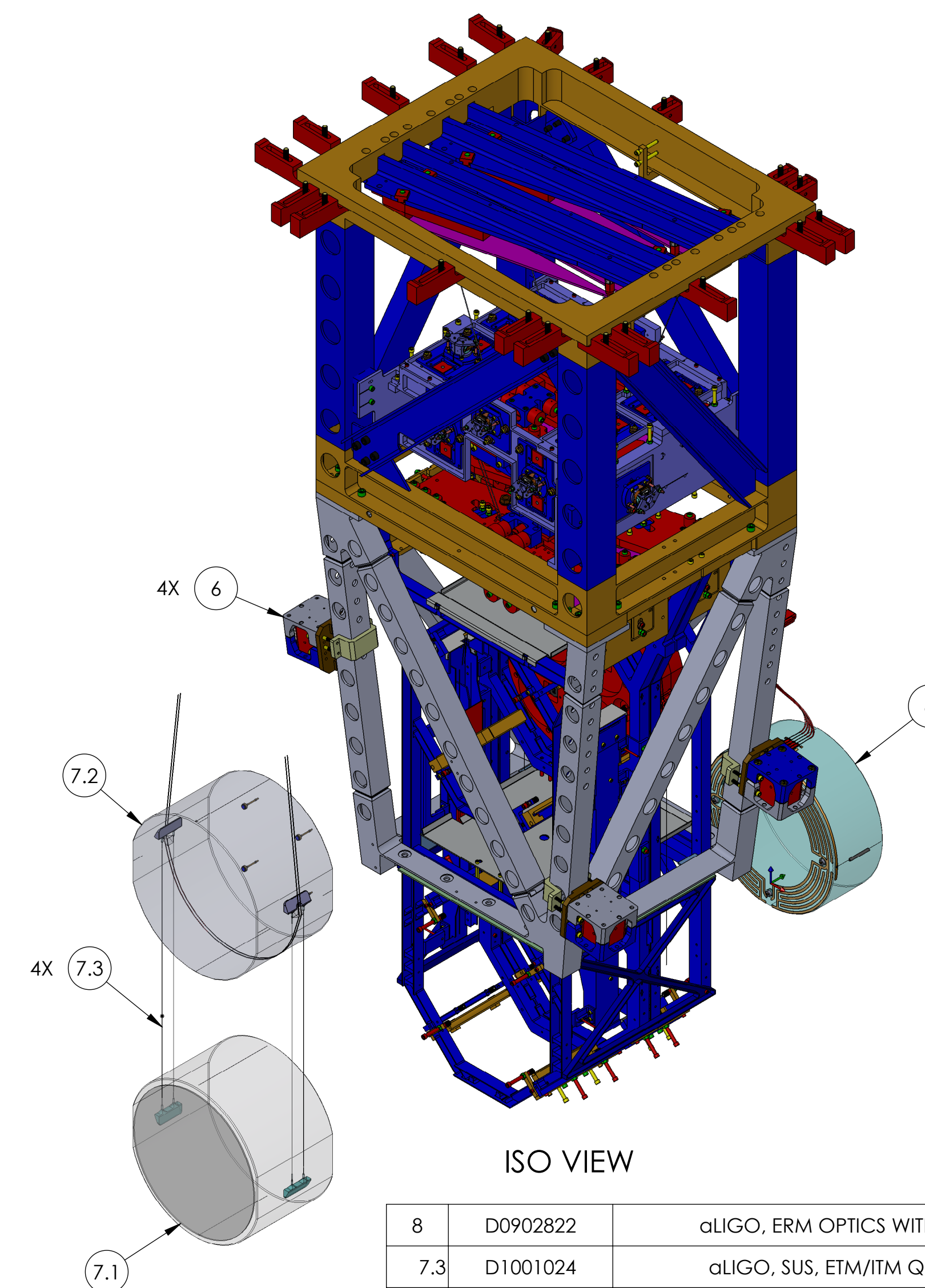

ISO VIEW

ITEM NO.	PART NUMBER	DESCRIPTION	QTY.
8	D0902822	αLIGO, ERM OPTICS WITH PRISM ASSEMBLY	1
7.3	D1001024	αLIGO, SUS, ETM/ITM QUAD, SILICA FIBRE	4
7.2	D0902823	ETM PENULTIMATE MASS (PM) WITH PRISMS AND EARS	1
7.1	D0902455	ETM OPTICS WITH EARS ASSEMBLY	1
7	D1000759	ETM PRODUCTION MONOLITHIC ASSEMBLY	1
6	D1002424	VIBRATION ABSORBER ASSEMBLY	4
5	D1100785-562	WASHER, FLAT, .68 X .562	20
4	3AJ1.500-12CL	3/8-16 X 1.50 12PT BOLT	20
3	D1003190	αLIGO QUAD SHORTER DOG CLAMP	5
2	D070056	αLIGO, SUS, QUAD N-PTYPE, QUAD DOG CLAMP	15
1	D0901346-04	D0901346-04	1

LOCAL COORDINATES REFERENCE

X mm	Y mm	Z mm	Yaw
-200.0	-531.9	-80.0	0.0

SEE PAGE 4 FOR CS DEFINITION

NOTES AND TOLERANCES: (UNLESS OTHERWISE SPECIFIED)

DIMENSIONS ARE IN INCHES [MM]	
MATERIAL	FINISH
--	-- μinch

LIGO CALIFORNIA INSTITUTE OF TECHNOLOGY
MASSACHUSETTS INSTITUTE OF TECHNOLOGY

SYSTEM: ADVANCED LIGO SUB-SYSTEM: SUS NEXT ASSY: D0900506

PART NAME: AdvLIGO SUS BSC5-L1, XYZ Local CS for ETMY

DESIGNER: ED CHAVEZ DATE: 22 APR 2013 SIZE: D DWG. NO.: D0900517 REV.: v3

CHECKER: APPROVAL: SCALE: 1:12 PROJECTION: SHEET 1 OF 5

D:\0900517 AdvLIGO SUS BSC5-L1_XYZ Local CS for ETMY_PART FDM REV: X-035 DRAWING FDM REV: X-003

1. USE ONLY ONE (1) ALIGNMENT TOOL. REMOVE AFTER ITMY IS CLAMPED TO ISI TABLE.
2. REFER TO G1000125 FOR ISI NAMING CONVENTION AND ORIENTATION CONVENTION.
3. REFER TO D1101271 FOR OPTICAL TABLE HOLE TABULATION CONVENTION.

A1 A10 A20 A30 A40 A50 A60 A70

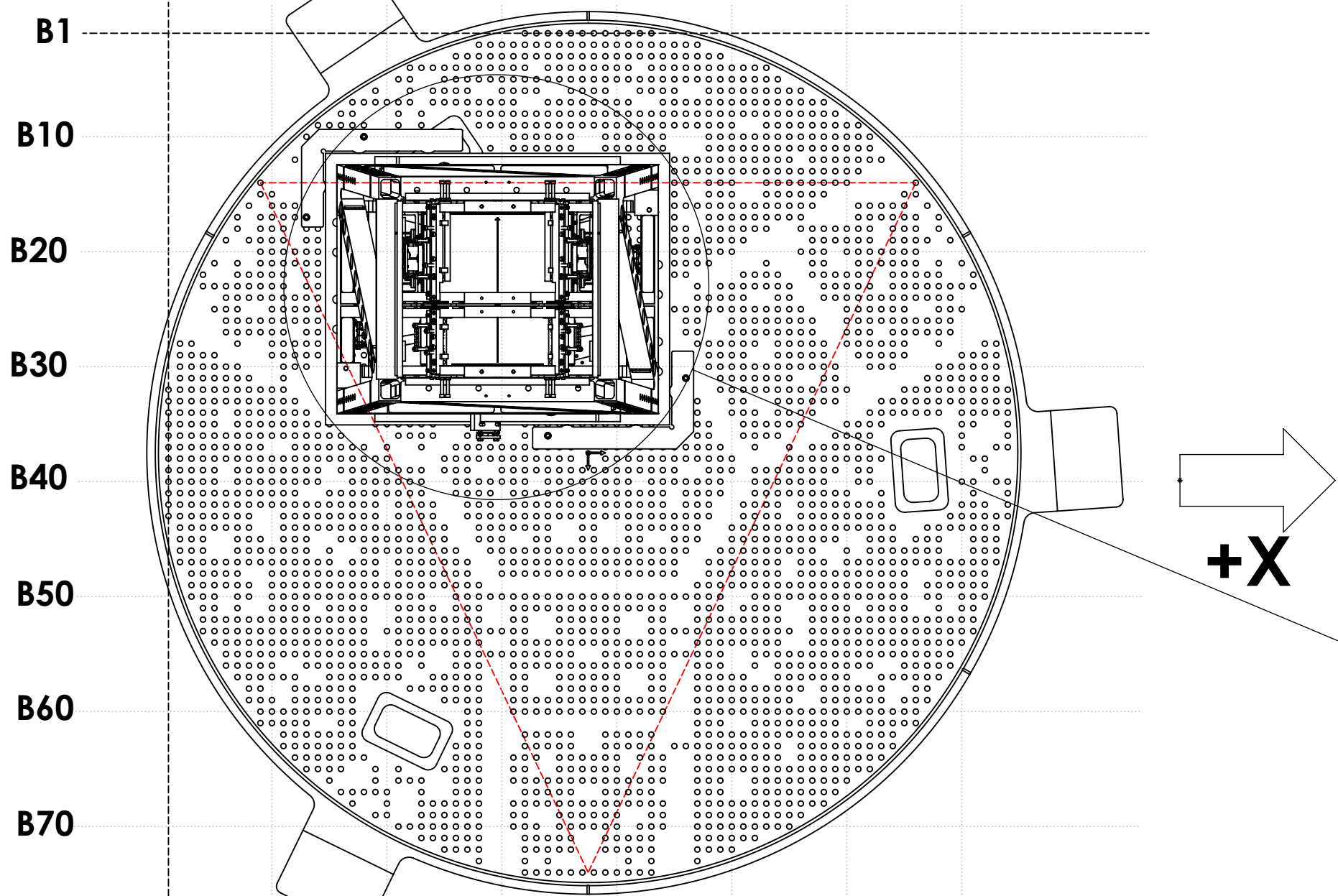

**BOTTOM VIEW
(LOOKING UP)**

BSC4-L1

+Y

BSC4-L1

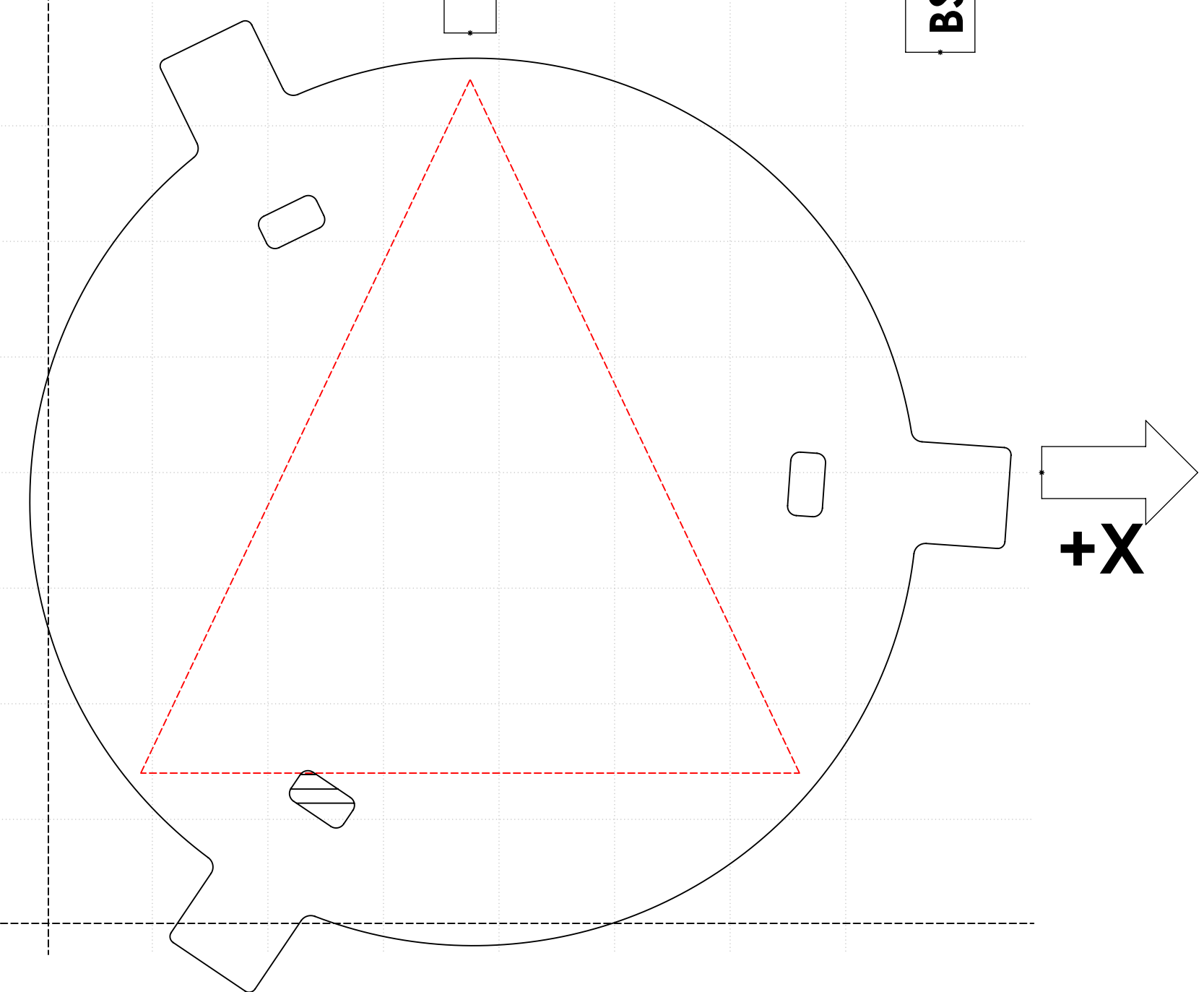

**TOP VIEW
(LOOKING DOWN)**

+X

SCREW HOLE
A18, B10
D1101050-17 "WBSC5A"

SCREW HOLE
A13, B17

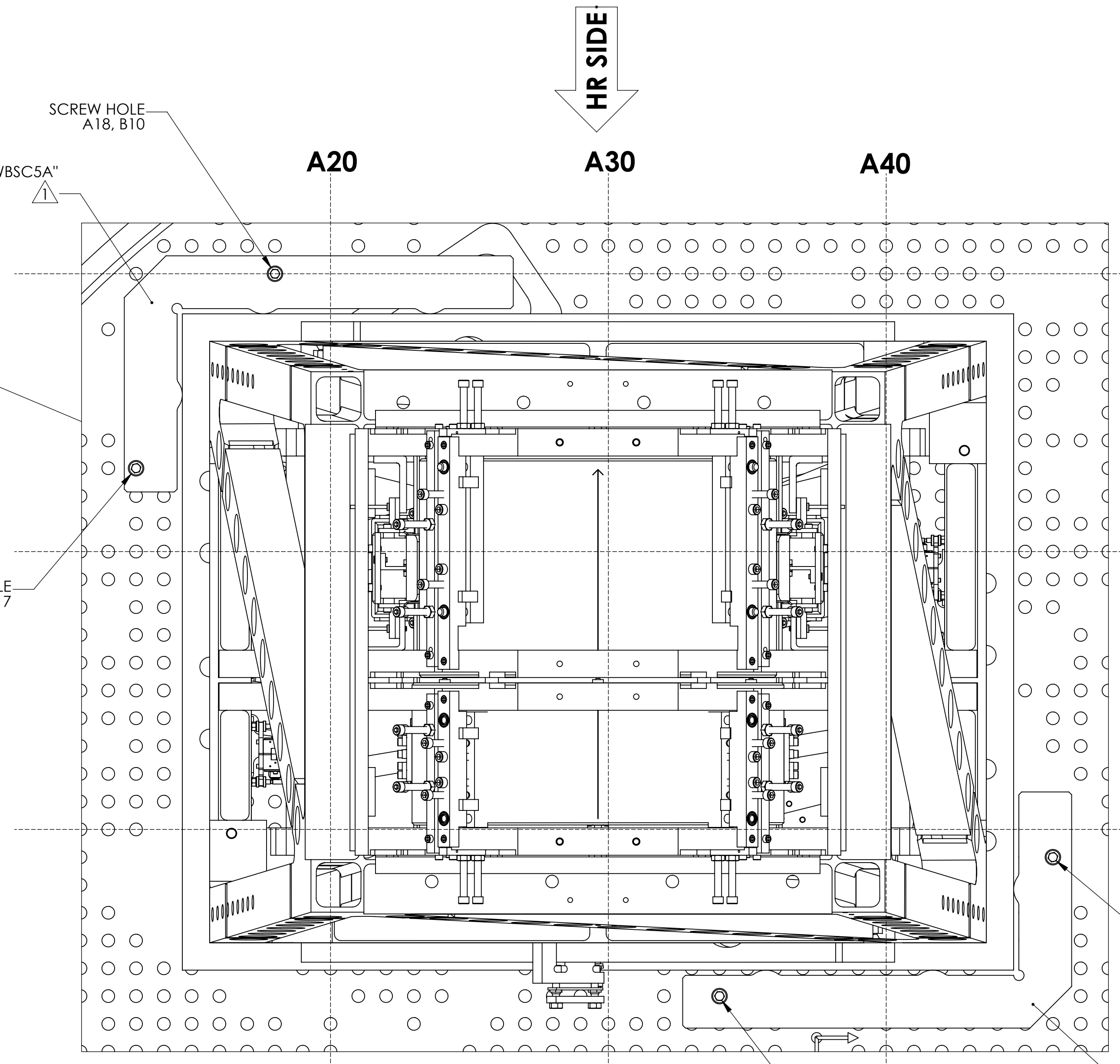

HR SIDE

AR SIDE

A20

A30

A40

B10

B20

B30

SCREW HOLE
A46, B31

D1101050-18 "WBSC5A"

SCREW HOLE
A34, B36

**BOTTOM VIEW (LOOKING UP)
D0901516 OPTICAL TABLE SHOWN FOR QUAD POSITIONING,
TEMPLATE LOCATION AND ORIENTATION ONLY. (VIBRATION ABSORBERS,
DOG CLAMPS AND MOUNTING HARDWARE NOT SHOWN FOR CLARITY).**

LIGO CALIFORNIA INSTITUTE OF TECHNOLOGY MASSACHUSETTS INSTITUTE OF TECHNOLOGY		REV.
SIZE DWG. NO.	D0900517	v3
SCALE: 1:12	PROJECTION:	SHEET 2 OF 5

D:\090517_A04\LIGO_S116_BSC-L1_XYZ.LOC\CS1\EMTY-PART.PDM.REV.X.035.DRAWING.PDM.REV.X.003

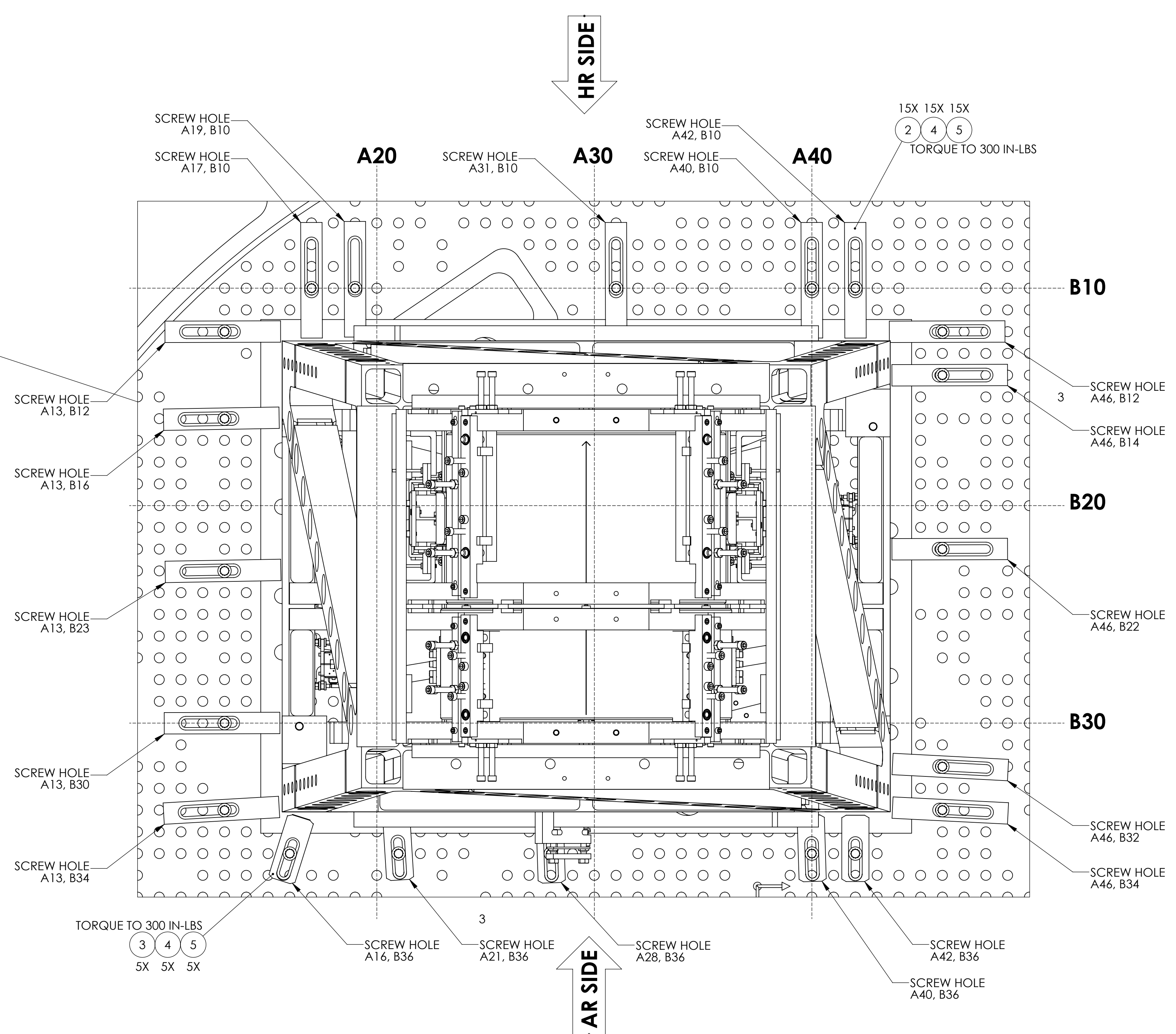
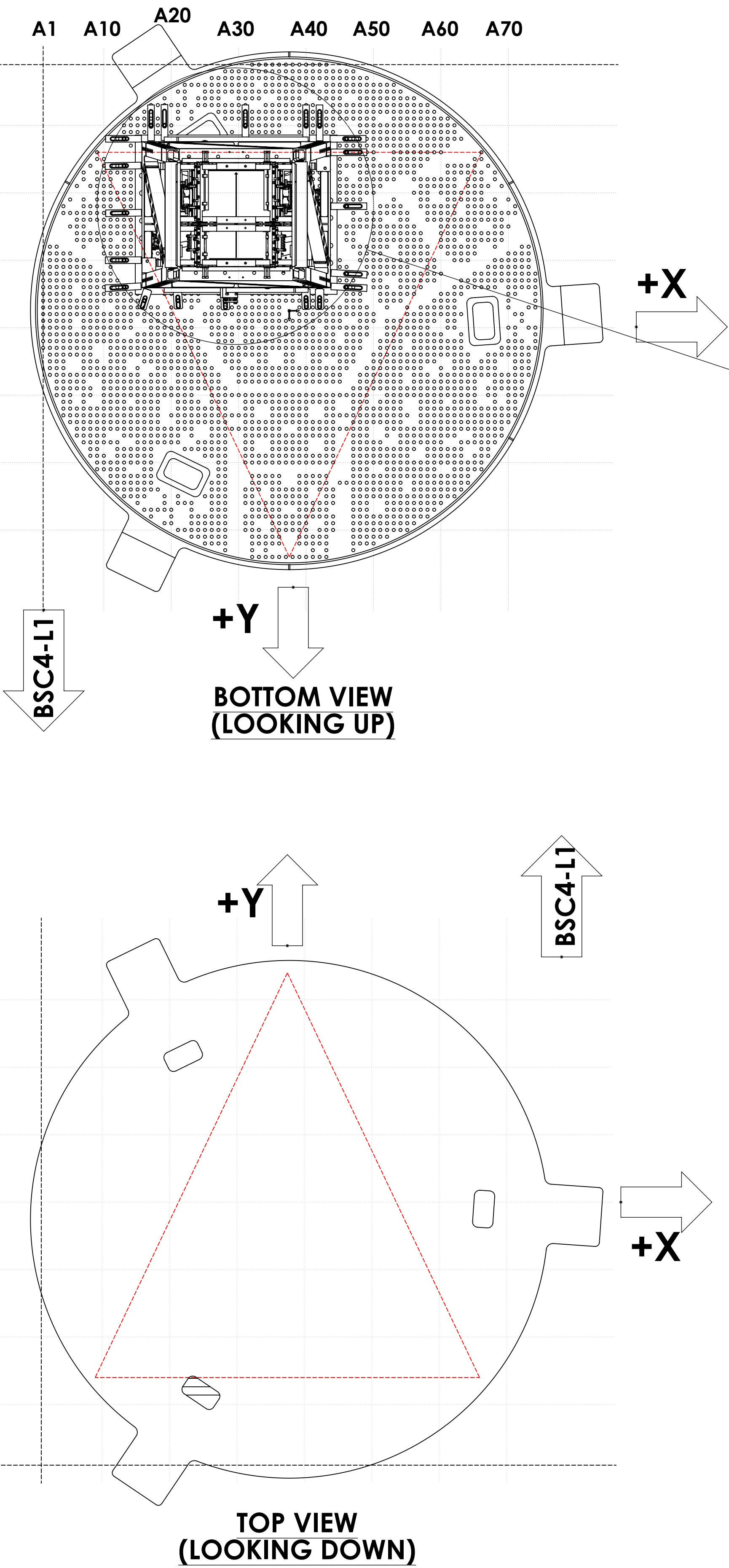

**BOTTOM VIEW (LOOKING UP)
D0901516 OPTICAL TABLE SHOWN FOR QUAD POSITIONING,
TEMPLATE LOCATION AND ORIENTATION ONLY. (VIBRATION ABSORBERS,
DOG CLAMPS AND MOUNTING HARDWARE NOT SHOWN FOR CLARITY).**

D0900517 Asm LIGO S16 BSC4-L1.XYZ Locs CS for EIMY - PART PDM REV: X.035. DRAWING PDM REV: X.003

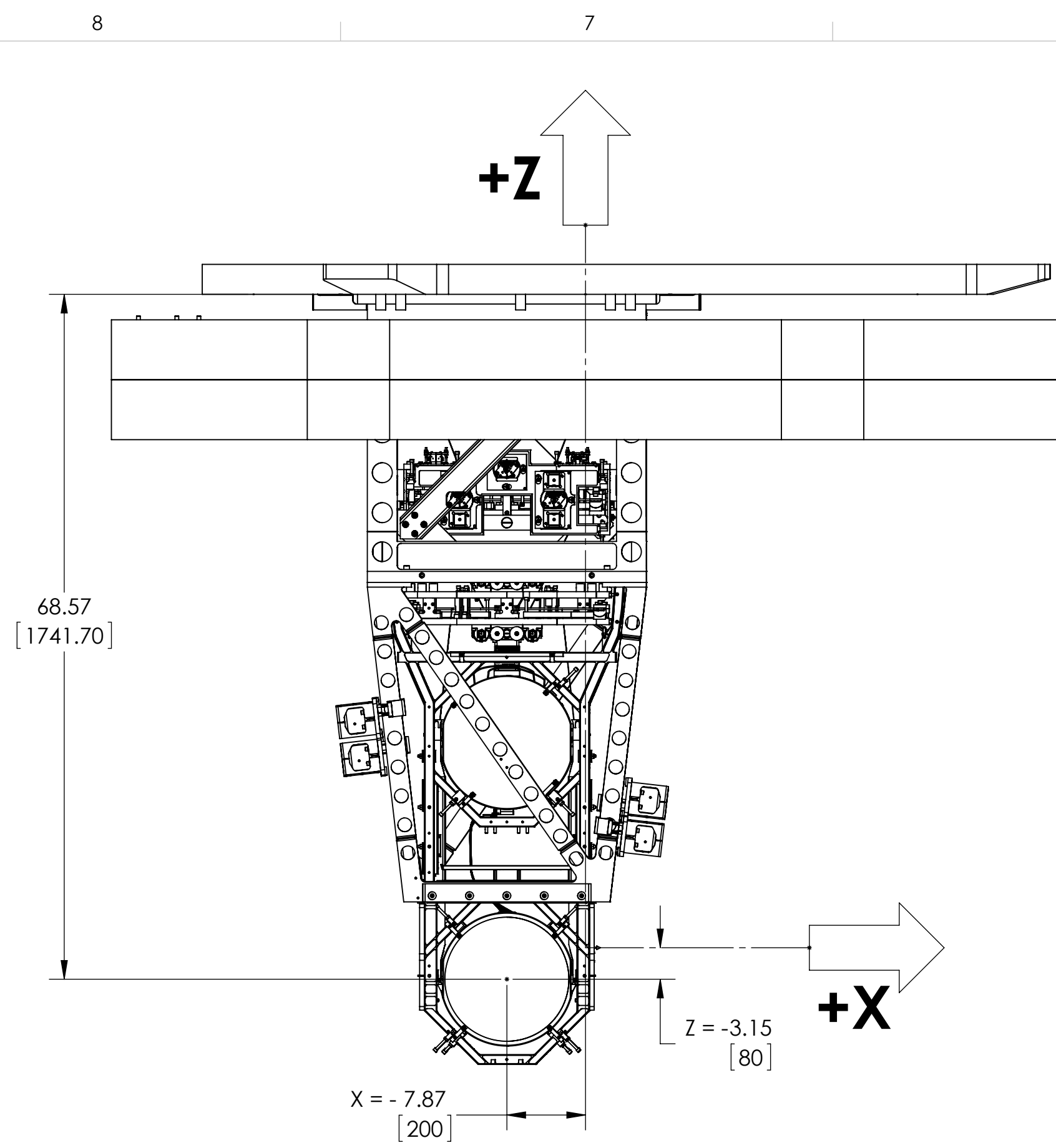

FRONT VIEW

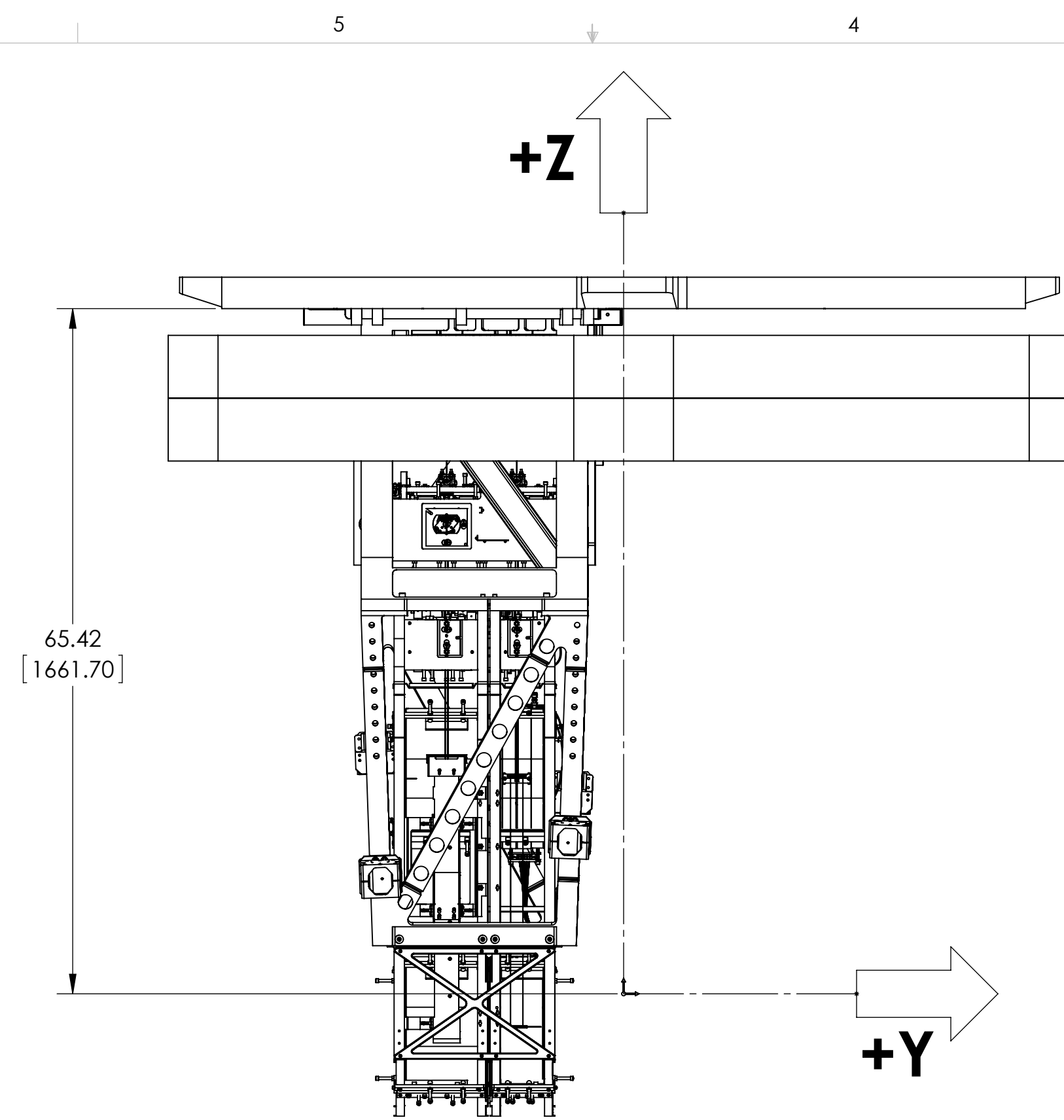

RIGHT VIEW

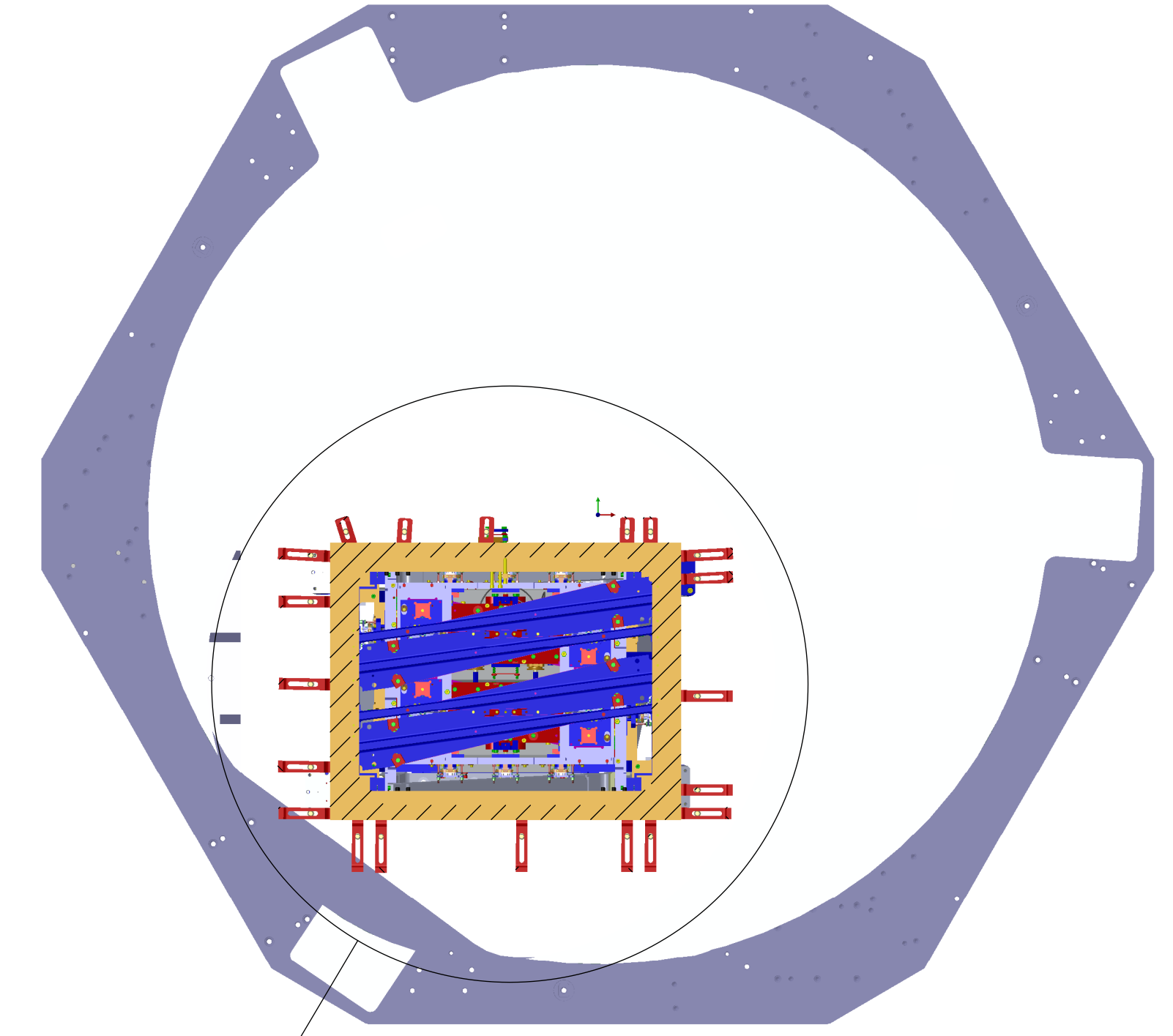

**TOP VIEW
(LOOKING DOWN)**

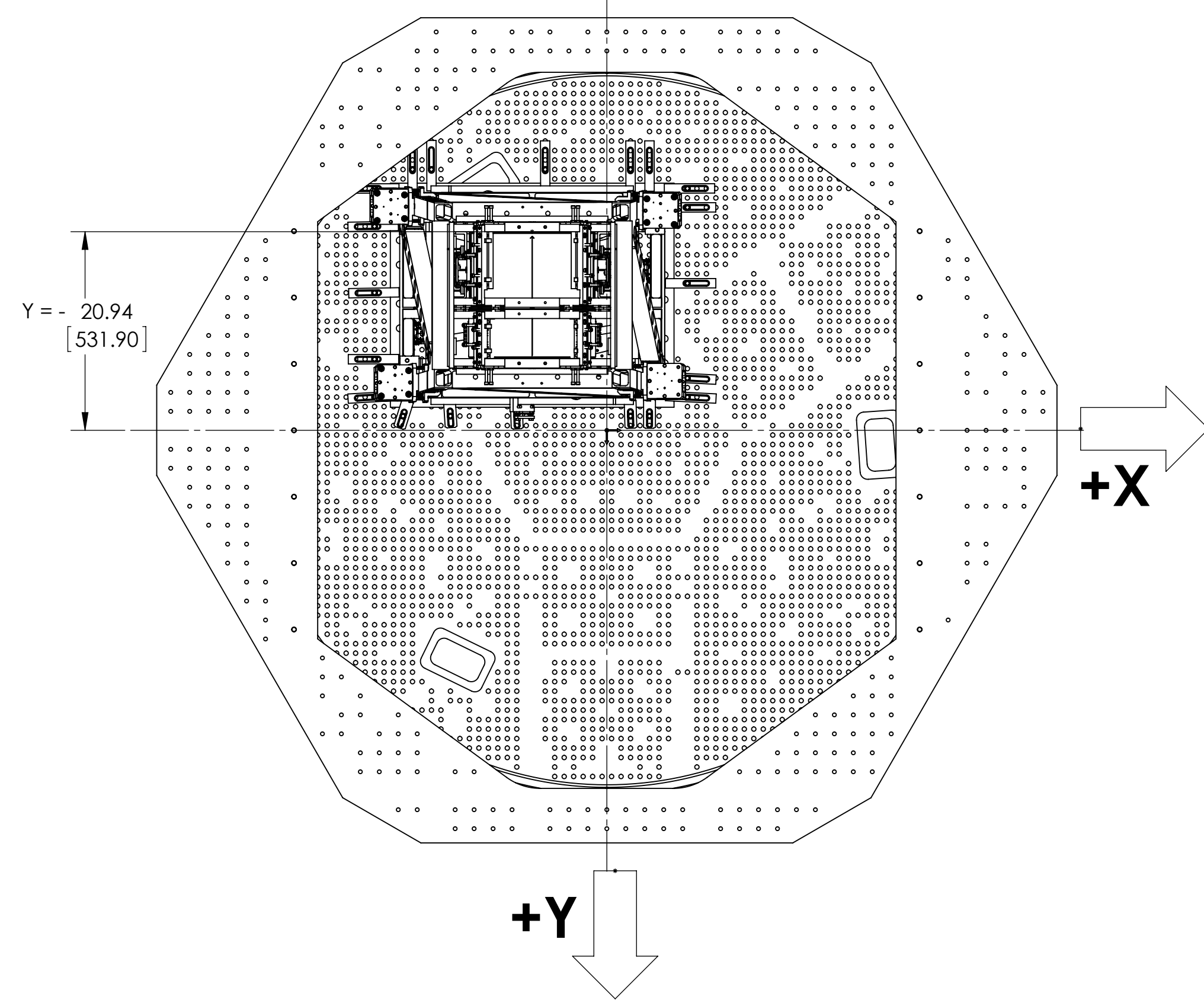

**BOTTOM VIEW
(LOOKING UP)**

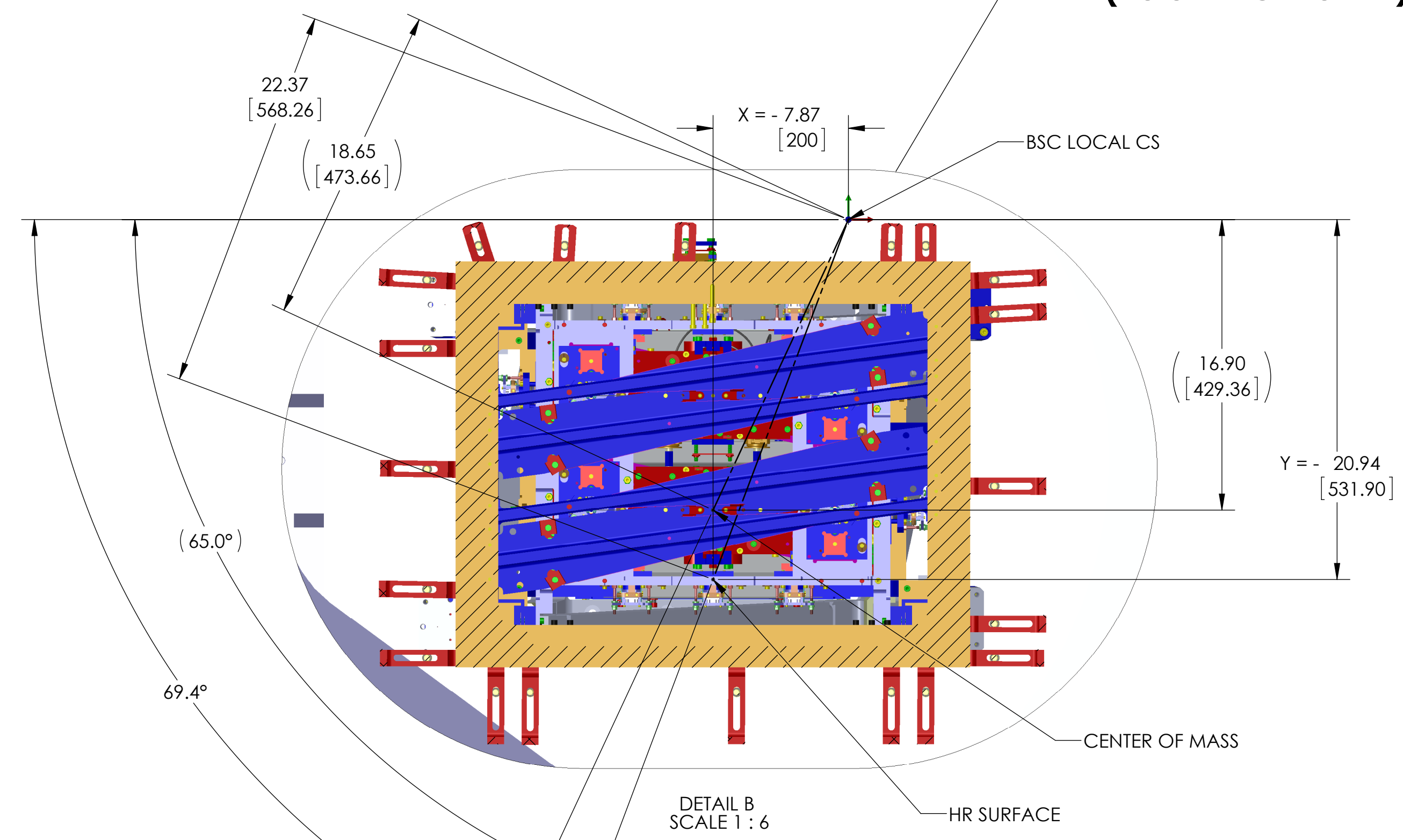

**DIMENSIONS IN PARENTHESIS
(REFERENCE DIMENSIONS)
ARE FROM CENTER OF MASS**

LIGO CALIFORNIA INSTITUTE OF TECHNOLOGY MASSACHUSETTS INSTITUTE OF TECHNOLOGY		REV.
SIZE	DWG. NO.	v3
D	D0900517	
SCALE: 1:24	PROJECTION:	SHEET 4 OF 5

DDP00517 Asm LIGO S16 BSC-L1.XYZ Local CS for ETMY PART PDM REV: X.035 DRAWING PDM REV: X.003

CABLE ROUTING SPECS.

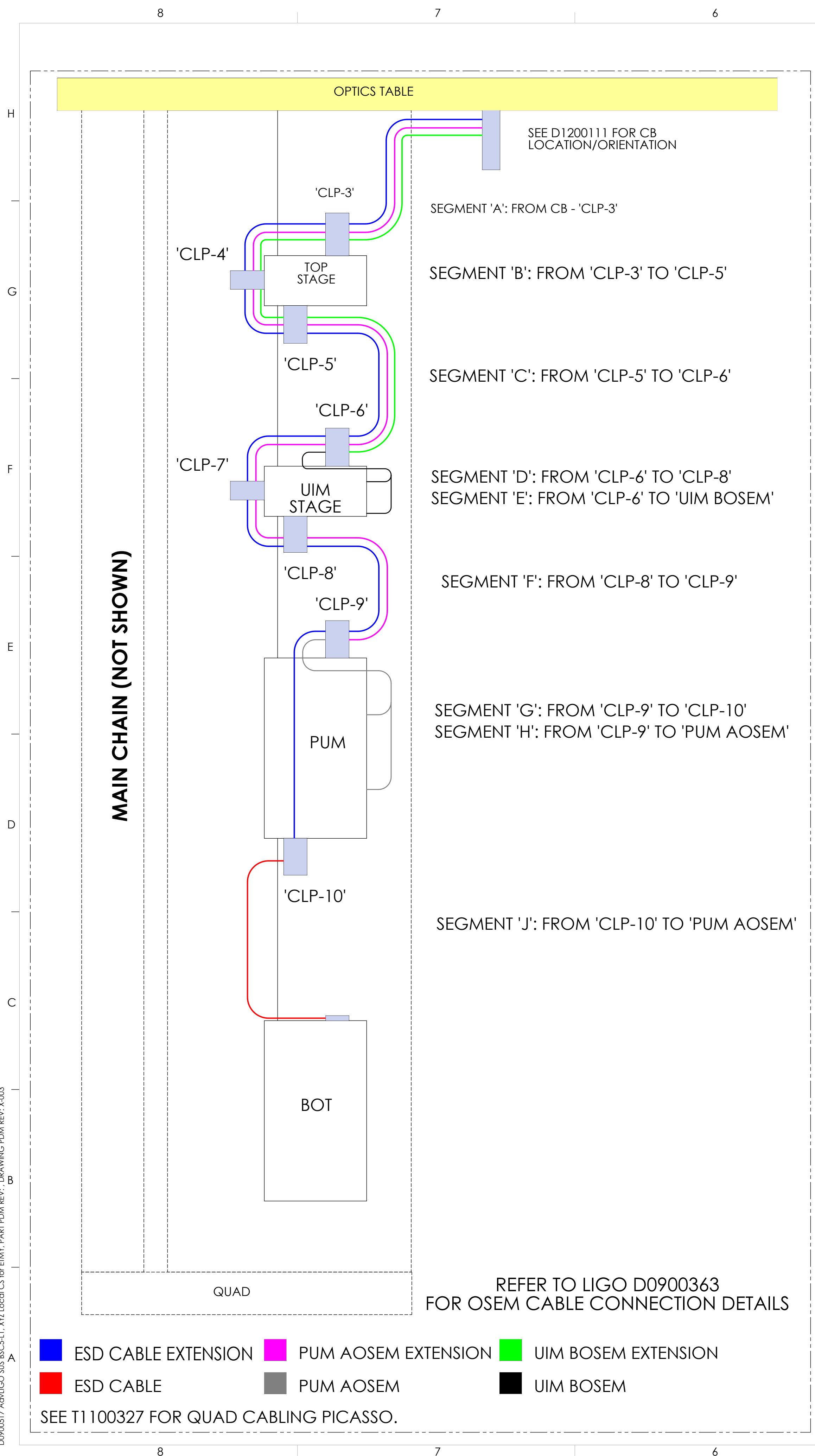

TABLE 1: BSC5-L1 ITMY CABLING SPECIFICATIONS, FROM/TO DES.

ROUTE NO.	FROM (OSEM POSITION)	TO CABLE EXTENSION	NOM. CABLE LENGTH (IN) (EXTENSION)	TO CB FLOOR DES.	QP LEG DES.	CABLE PART NO.	NOM. CABLE LENGTH (IN)
1	M0-F1	N/A	N/A	CB-3 (FIRST)	A	D1000234	88
	M0-F2				B		
	M0-F3				C		
	M0-SIDE				D		
2	R0-F1	N/A	N/A	CB-3 (3RD)	A	D1000234	88
	R0-F2				B		
	R0-F3				C		
	R0-SIDE				D		
3	M0-LEFT	N/A	N/A	CB-3 (2ND)	A	D1000234	88
	M0-RIGHT				B		
	R0-LEFT				C		
	R0-RIGHT				D		
4	UIM-UL	D1002522	121	CB-4 (FIRST)	A	D1002523	12
	UIM-LL				B		
	UIM-UR				C		
	UIM-LR				D		
5	PUM-UL	D1002522	156	CB-4 (SECOND)	A	D1002524	17
	PUM-LL				B		
	PUM-UR				C		
	PUM-LR				D		
6	D1002225	D1101472	175	CB-3	N/A	N/A	N/A

NOTE : FOR CABLE ROUTING DETAILS, CLAMP LOCATIONS/ORIENTATION, AND CABLE DIAGRAMS, SEE LIGO D0900363 SHEETS 4 -9.