

NOTES CONTINUED:
 ⑤ Reference DCC # 1010074-02

REV.	DATE	DCN #	DRAWING TREE #
-	-	-	-
-	-	-	-
-	-	-	-

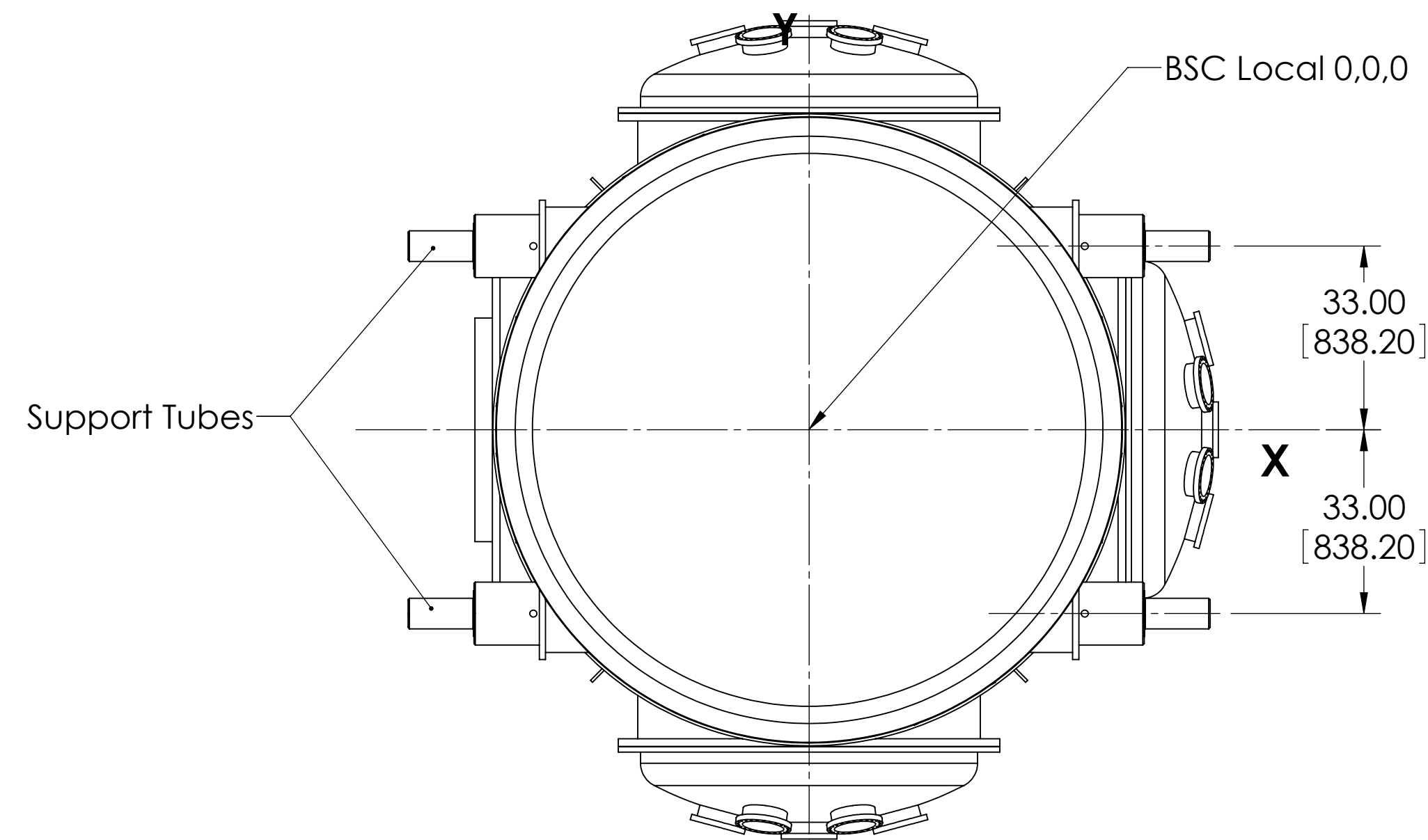

TOP VIEW

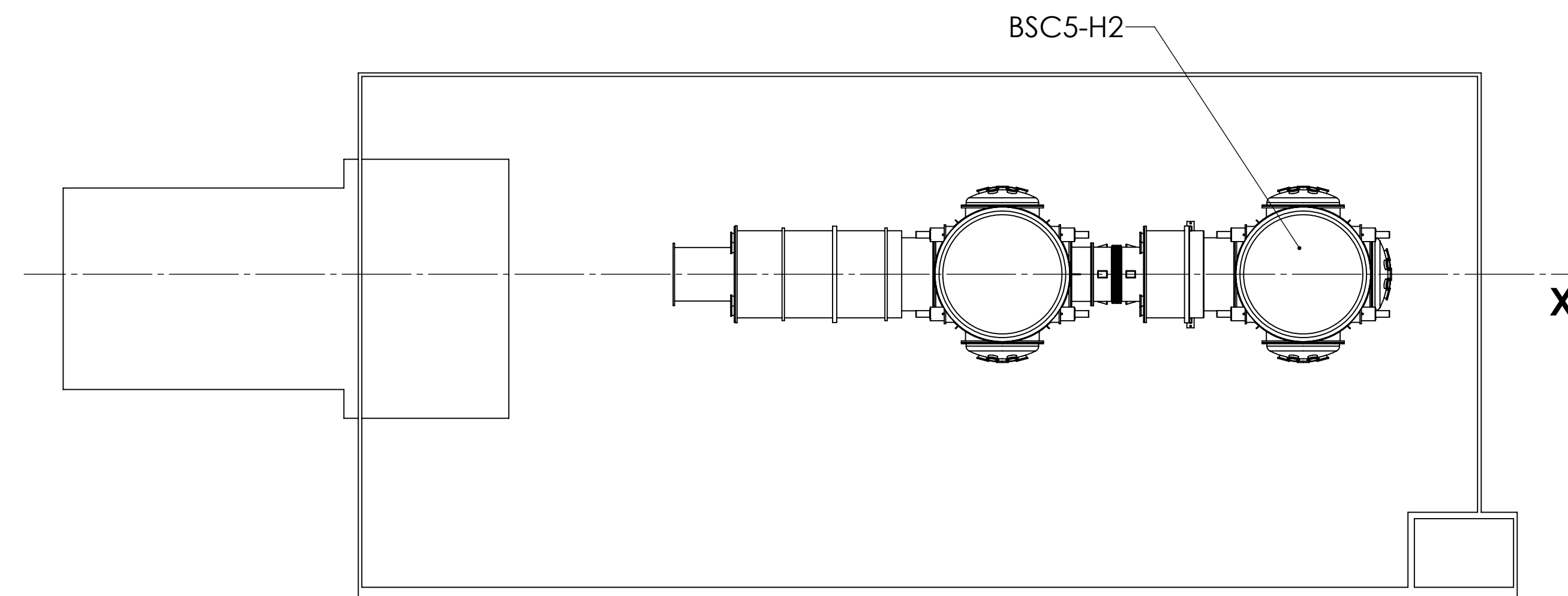

LHO X-END STATION

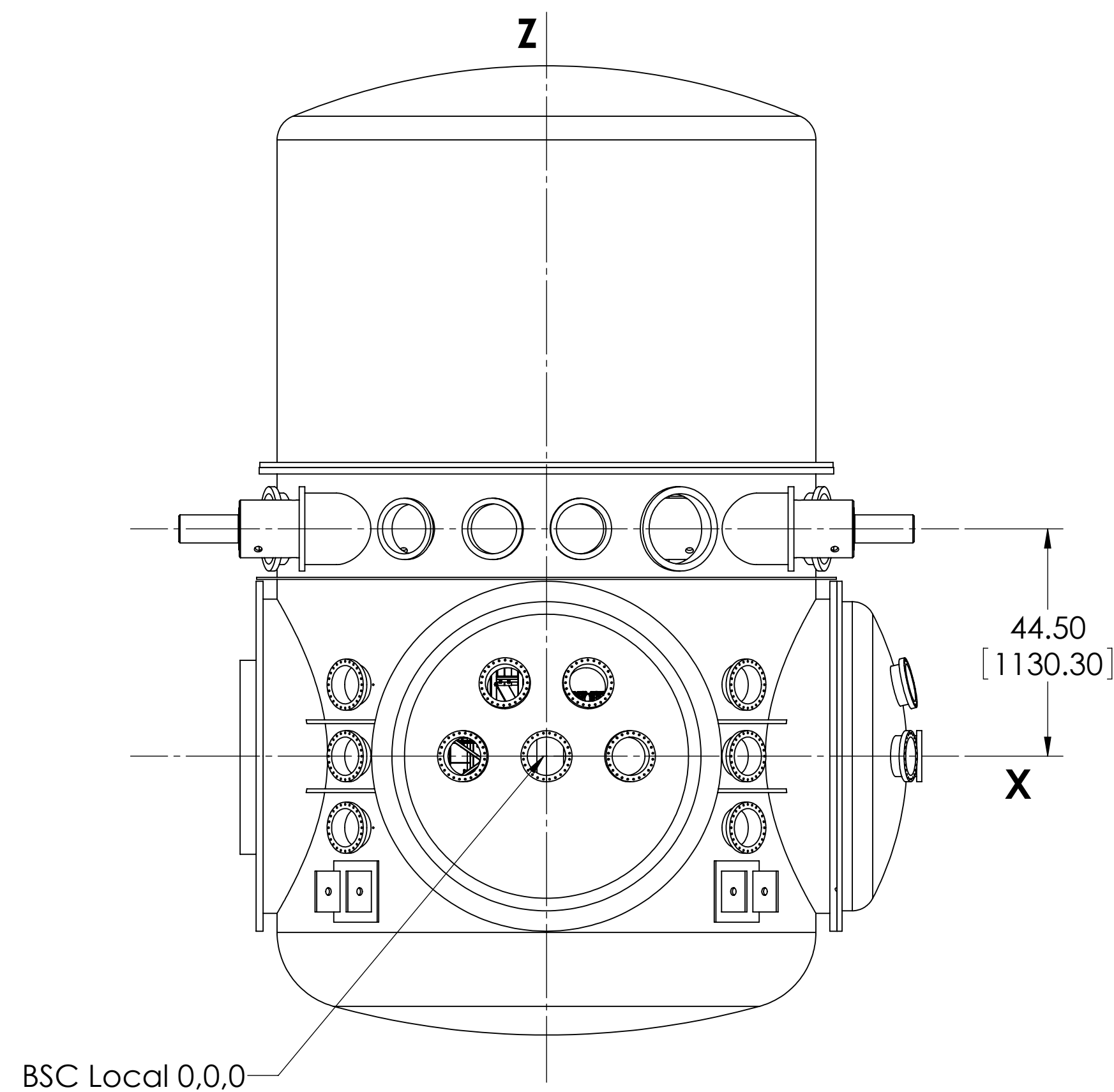

FRONT VIEW

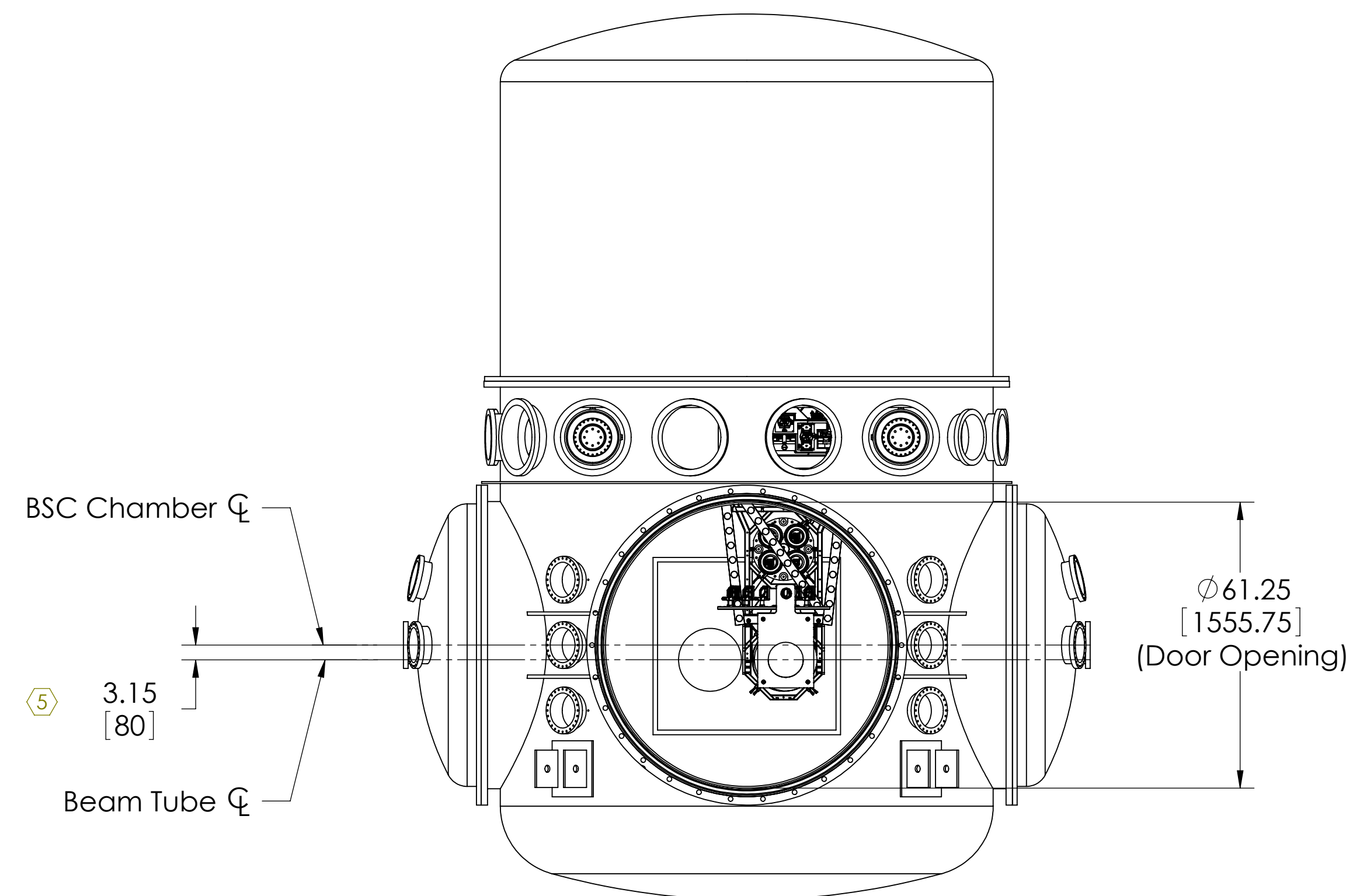

RIGHT SIDE VIEW

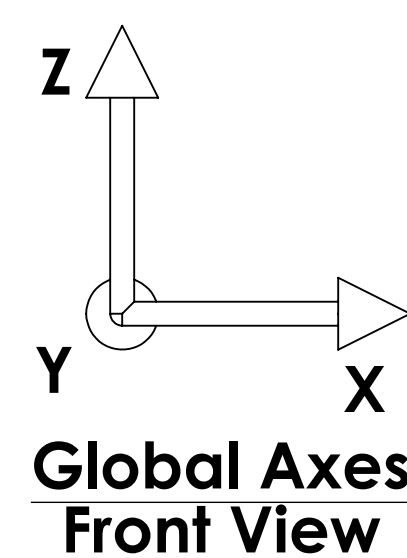
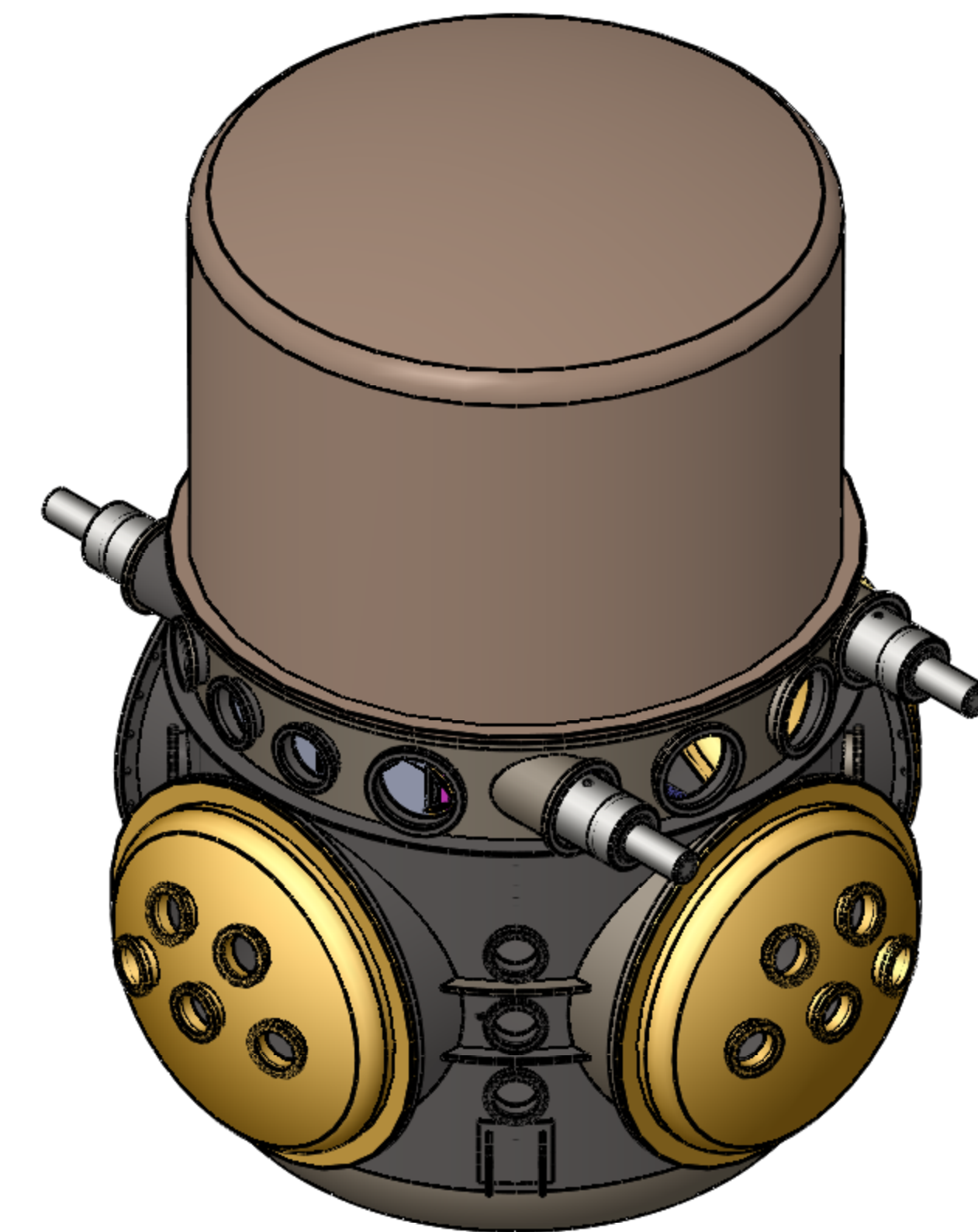

BSC5-H2 GLOBAL COORDINATES (mm)	
X	4006370.0
Y	0.0
Z	0.0

NOTES AND TOLERANCES: (UNLESS OTHERWISE SPECIFIED)	
DIMENSIONS ARE IN INCHES	
TOLERANCES: .XX ± 0.01 .XXX ± 0.005	
ANGULAR ± 0.5°	
1. INTERPRET DRAWING PER ASME Y14.5-1994. 2. REMOVE ALL SHARP EDGES, R.02 MIN. 3. DO NOT SCALE FROM DRAWING. 4. ALL MACHINING FLUIDS SHALL BE WATER SOLUBLE AND FREE OF SULFUR, CHLORINE AND SILICONE, SUCH AS CINCINNATI MILACRON'S CIMTECH 410.	
MATERIAL	FINISH
--	-- μinch

CALIFORNIA INSTITUTE OF TECHNOLOGY MASSACHUSETTS INSTITUTE OF TECHNOLOGY	PART NAME	
	BSC5-H2 Top Level Chamber Assembly, Fully Detailed	
SYSTEM	SUB-SYSTEM	DESIGNER
ADVANCED LIGO	SUS	ED CHAVEZ
NEXT ASSY	CHECKER	DATE
		16 SEPT 2009
	APPROVAL	SIZE DWG. NO.
		D 4006370.0

SCALE: 1:32	PROJECTION:	SHEET 1 OF 4
-------------	-------------	--------------

D0900502.BSC5-H2 Top Level Chamber Assembly, Complicated-1.PART PDM REV: X-004, DRAWING PDM REV: X-000

NOTES CONTINUED:
 ⑤ Reference DCC # 1010074-02

REV.	DATE	DCN #	DRAWING TREE #
-	-	-	-
-	-	-	-
-	-	-	-

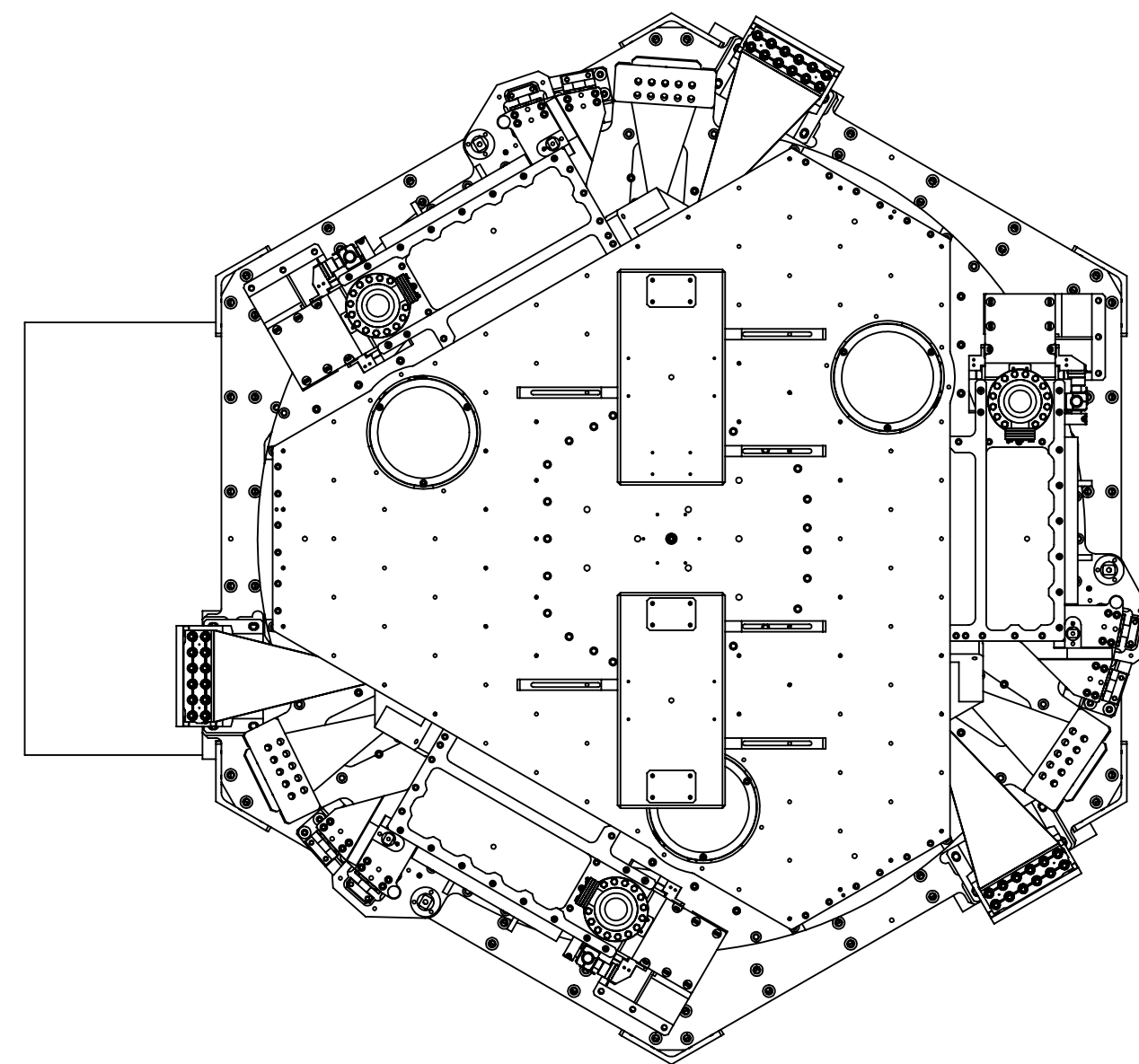

TOP VIEW

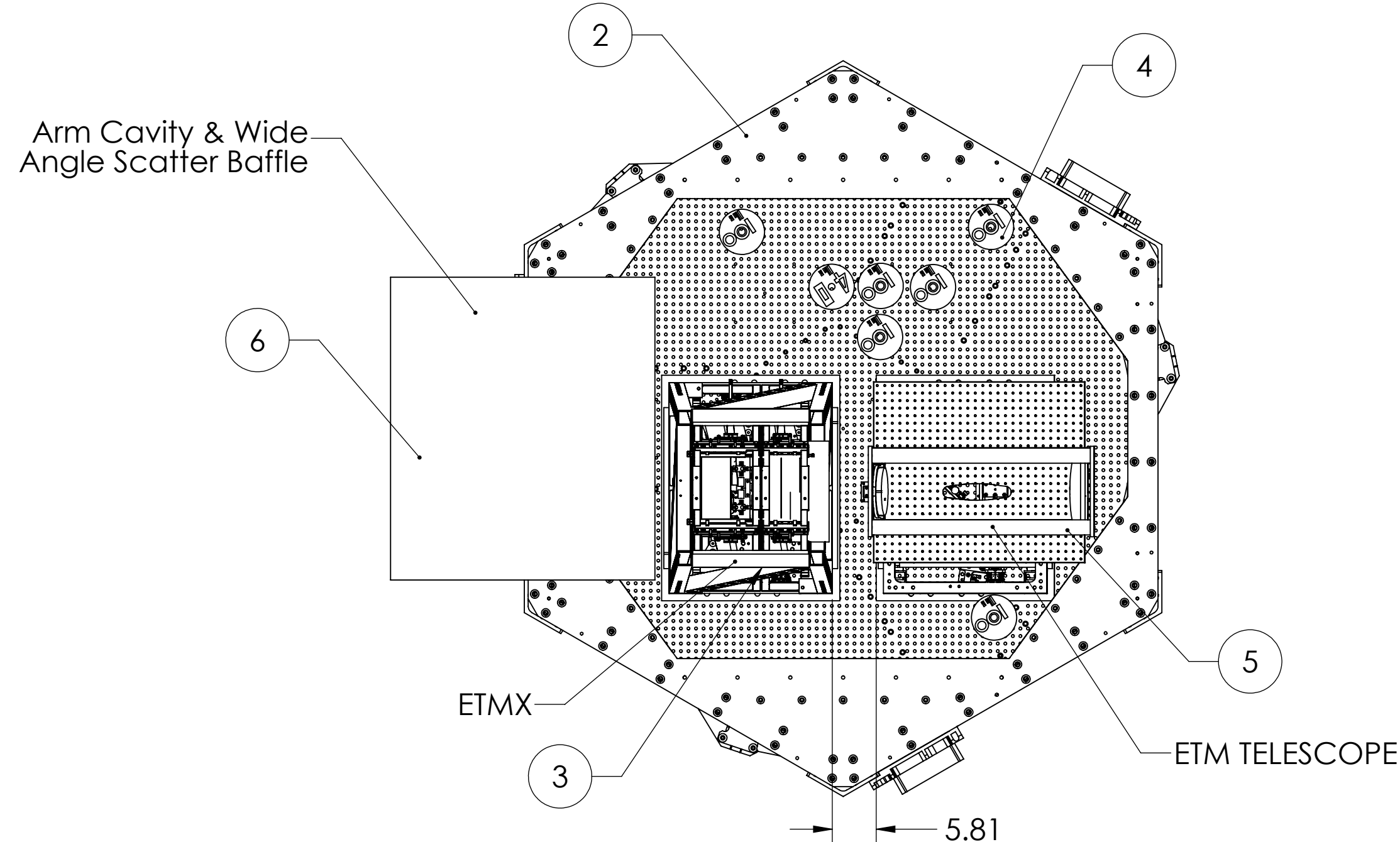

BOTTOM VIEW

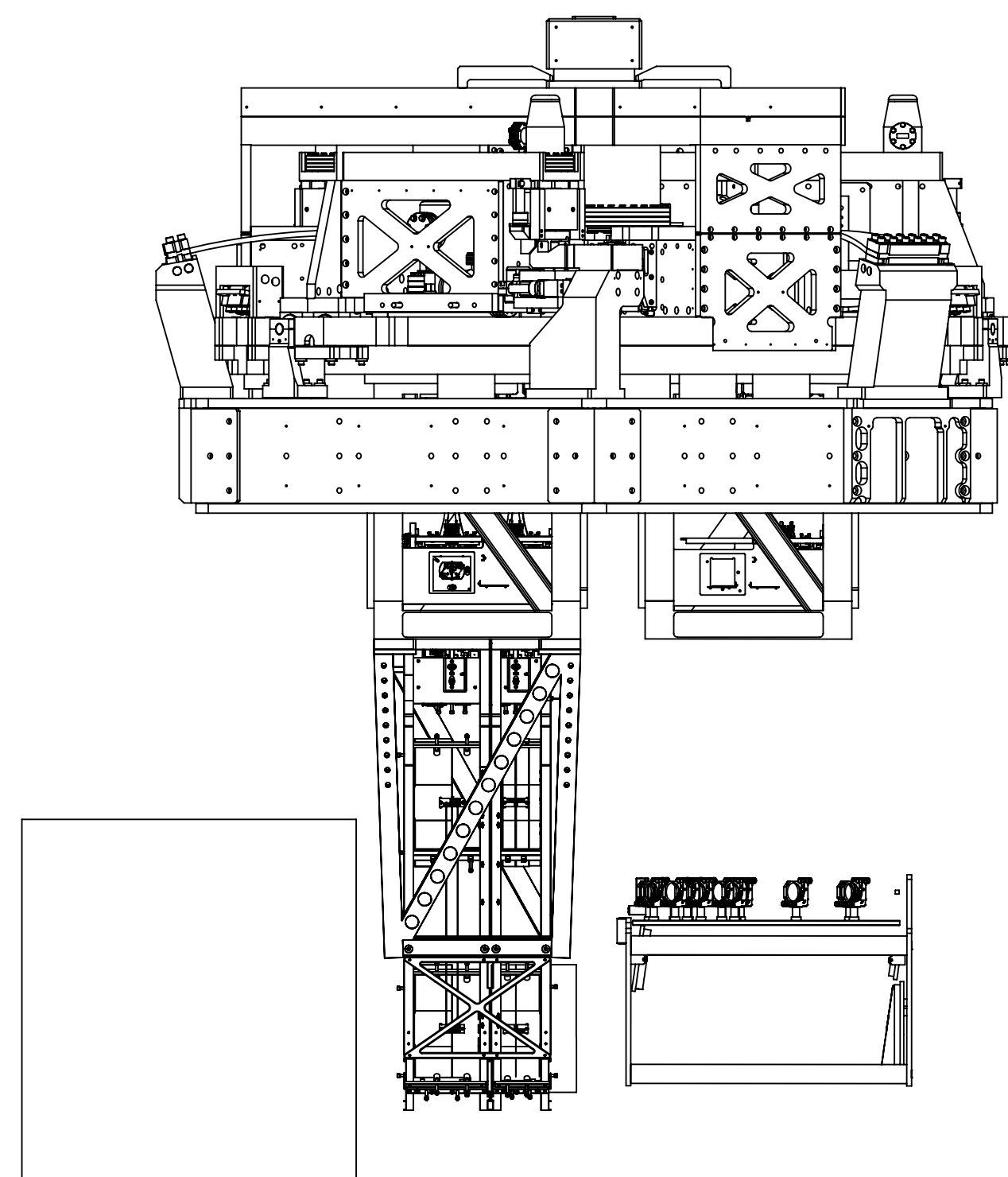
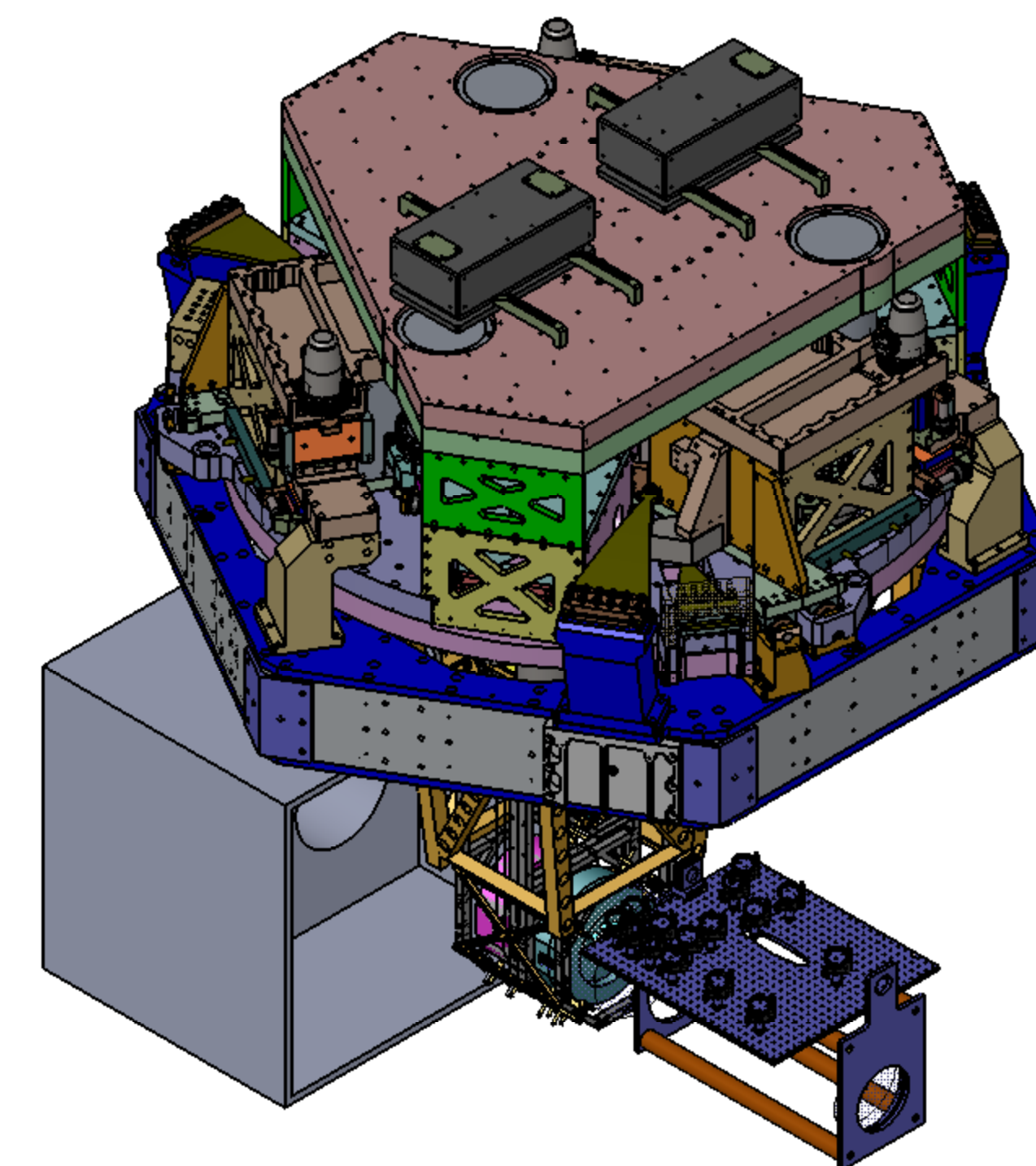

FRONT VIEW

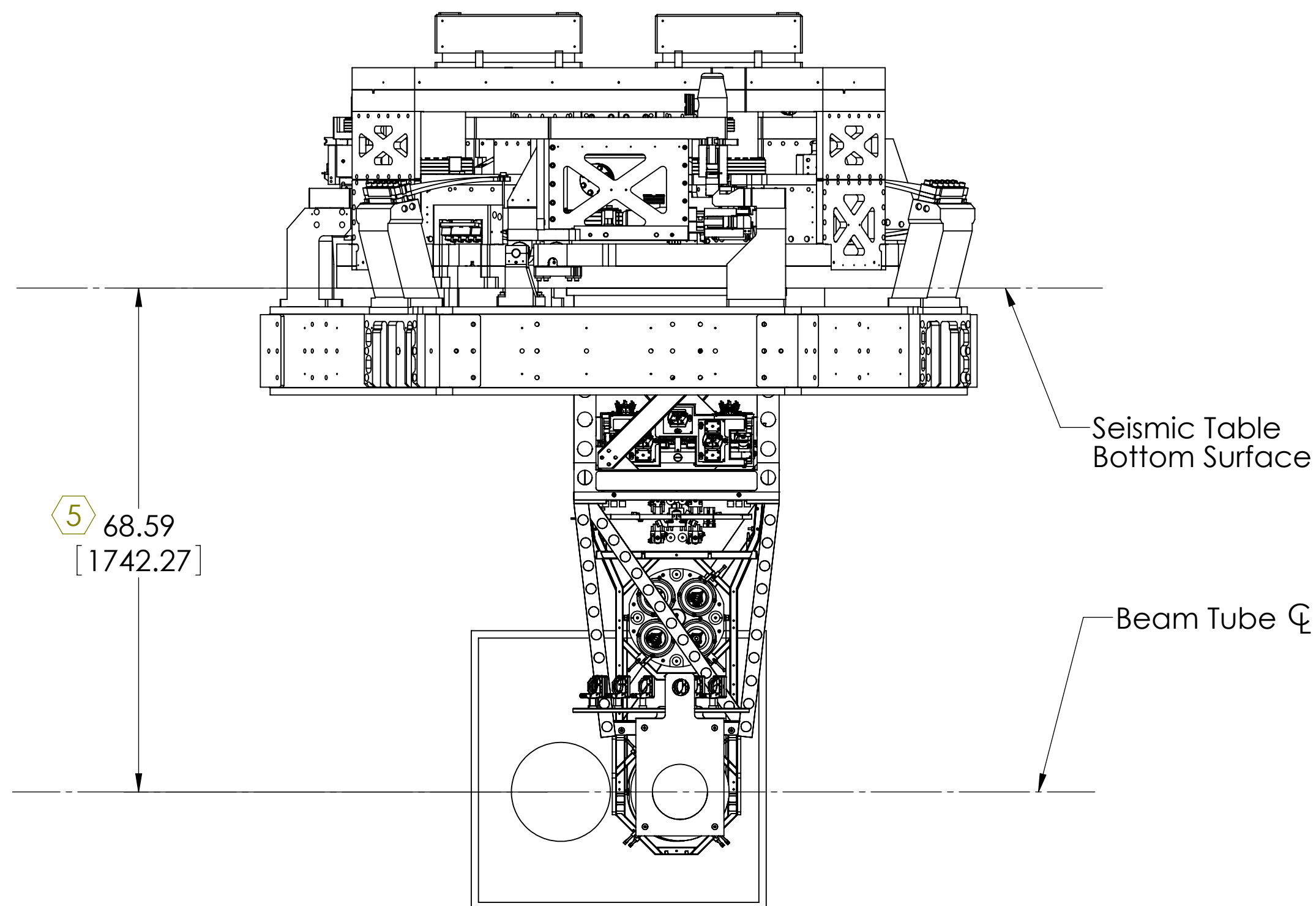

RIGHT SIDE VIEW

ITEM NO.	PART NUMBER	DESCRIPTION	MATERIAL	Complicated/QTY.	SPARE	TOTAL
6		AdvLIGO SUS BSC5-H2, XYZ Local CS for ETM Tel Assy	--	1		0
5	D0900411	AdvLIGO Systems SEI Table Counterweight Assy	--	1		0
4	D0900344	AdvLIGO Systems SEI Table Counterweight Assy	--	1		0
3	D0900505	AdvLIGO SUS BSC5-H2, XYZ Local CS for ETMX	--	1		0
2	D0900504	AdvLIGO SEI BSC5-H2, XYZ Local CS for SI Table	--	1		0
NOT SHOWN	D0900503	AdvLIGO VE BSC5-H2, Vacuum Equipment Assembly	--	1		0

BSC5-H2 GLOBAL COORDINATES (mm)	
X	4006370.0
Y	0.0
Z	0.0

DIMENSIONS ARE IN INCHES
 TOLERANCES:
 .XX ± 0.01
 .XXX ± 0.005
 ANGULAR ± 0.5°

NOTES AND TOLERANCES: (UNLESS OTHERWISE SPECIFIED)

1. INTERPRET DRAWING PER ASME Y14.5-1994.
2. REMOVE ALL SHARP EDGES, R.02 MIN.
3. DO NOT SCALE FROM DRAWING.
4. ALL MACHINING FLUIDS SHALL BE WATER SOLUBLE AND FREE OF SULFUR, CHLORINE AND SILICONE, SUCH AS CINCINNATI MILACRON'S CIMTECH 410.

MATERIAL: -- FINISH: -- μinch

LIGO CALIFORNIA INSTITUTE OF TECHNOLOGY
 MASSACHUSETTS INSTITUTE OF TECHNOLOGY

SYSTEM: ADVANCED LIGO SUB-SYSTEM: SUS

NEXT ASSY:

PART NAME: BSC5-H2 Top Level Chamber Assembly, Fully Detailed

DESIGNER: ED CHAVEZ
 DRAFTER: ED CHAVEZ
 CHECKER:
 APPROVAL:

SIZE: D DWG. NO.: D0900502
 DATE: 15 SEPT 2009

SCALE: 1:32 PROJECTION: SHEET 2 OF 4

D0900502 BSC5-H2 Top Level Chamber Assembly, Complicated II, PART PDM REV: X-002, DRAWING PDM REV: X-000

NOTES CONTINUED:
 ⑤ Reference DCC # 1010074-02

REV.	DATE		DRAWING TREE #
-	-	-	-
-	-	-	-
-	-	-	-

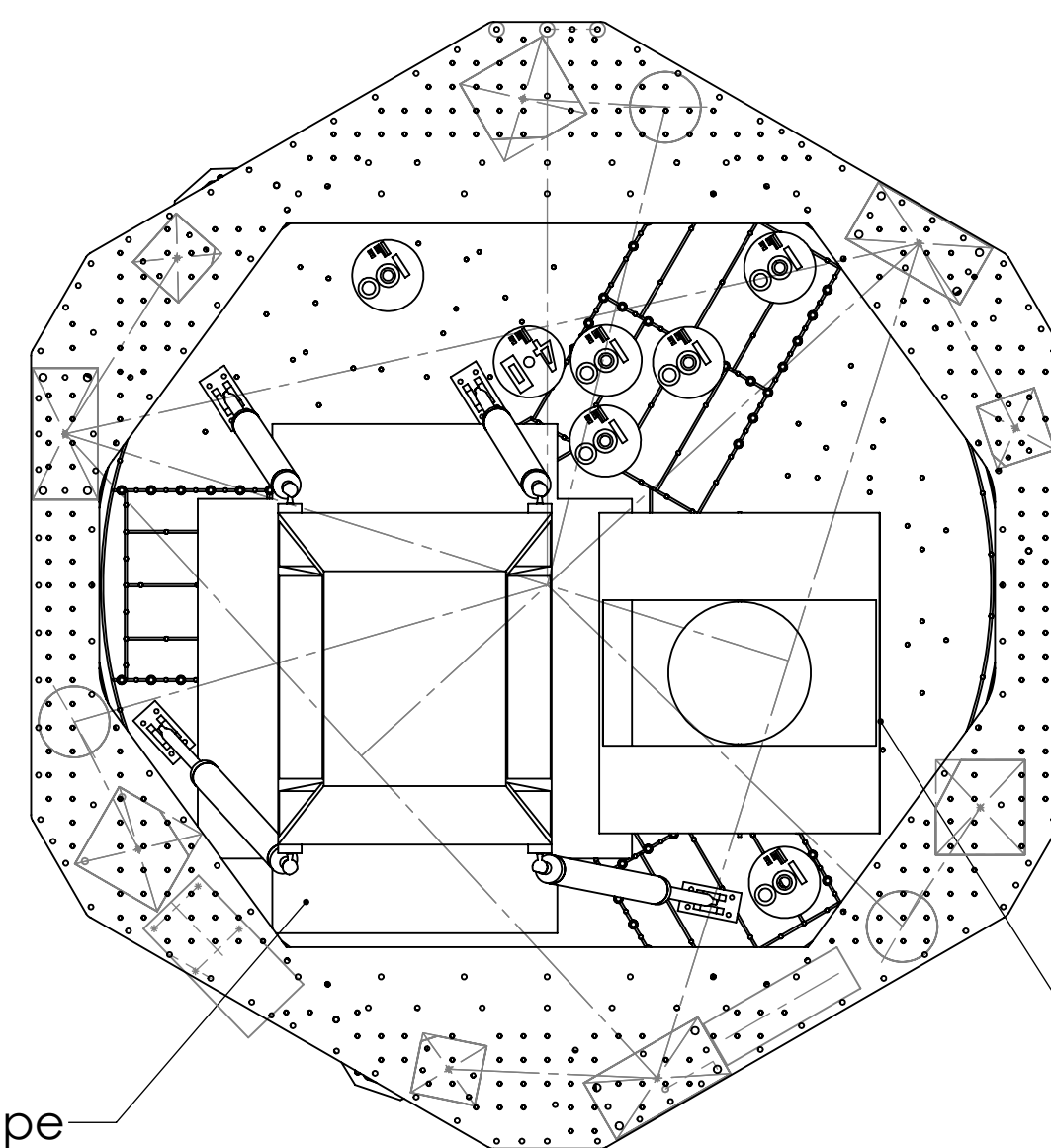
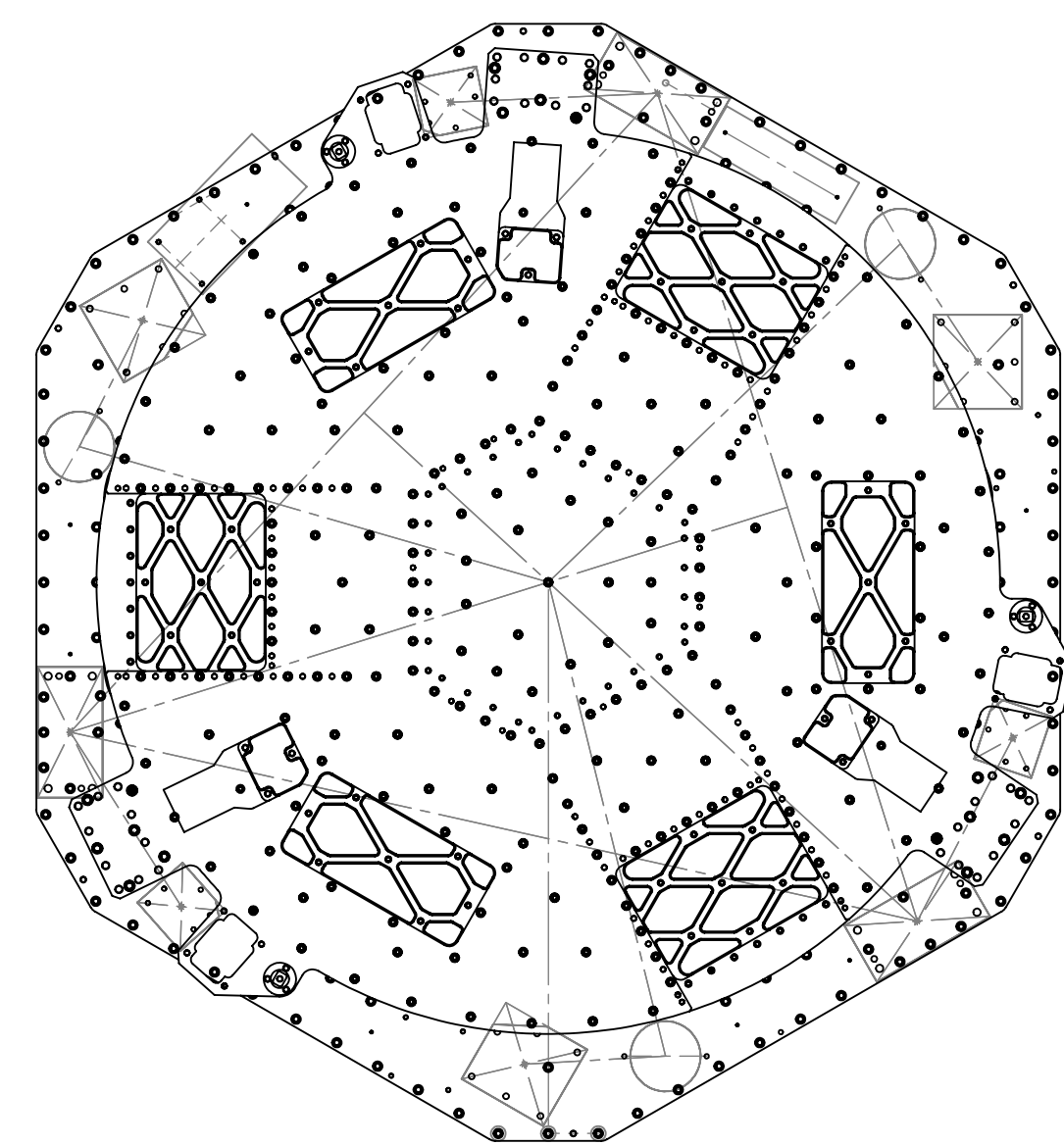

ETMX Envelope

ETM Telescope

BOTTOM VIEW

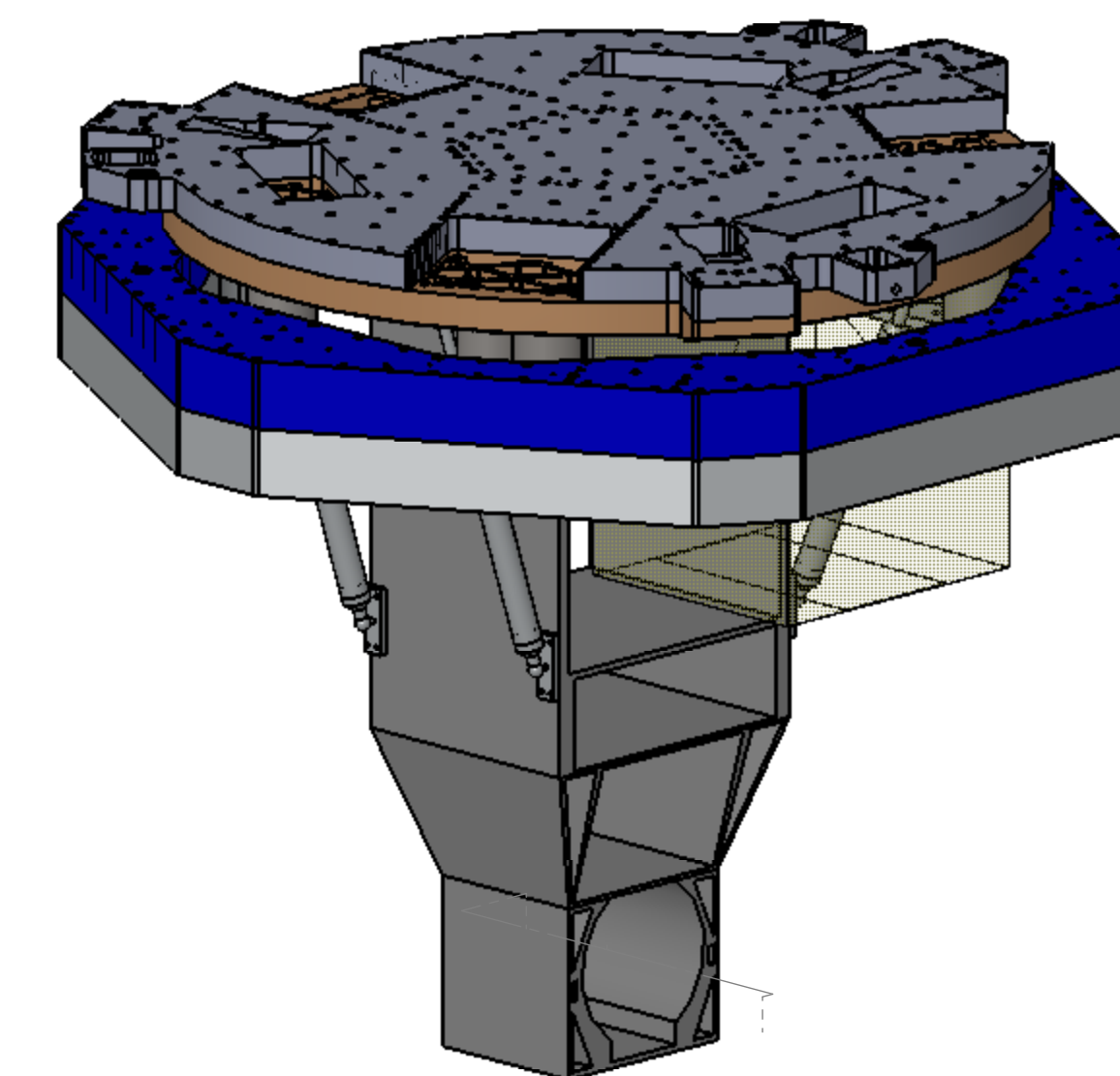

**NO SUSPENDED MASS &
NO CHAMBER SHOWN**

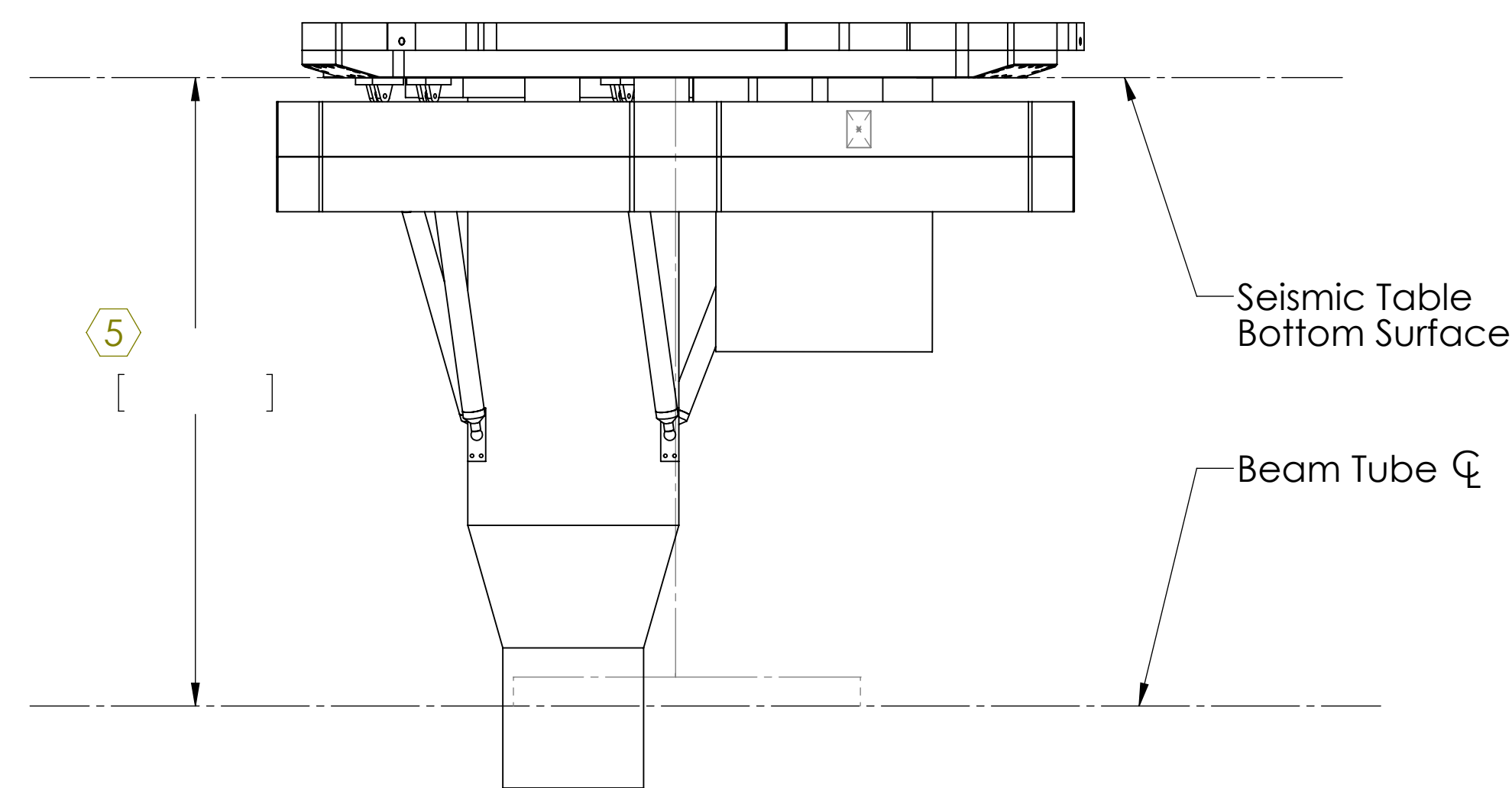

Seismic Table
Bottom Surface

Beam Tube \varnothing

⑤

FRONT VIEW

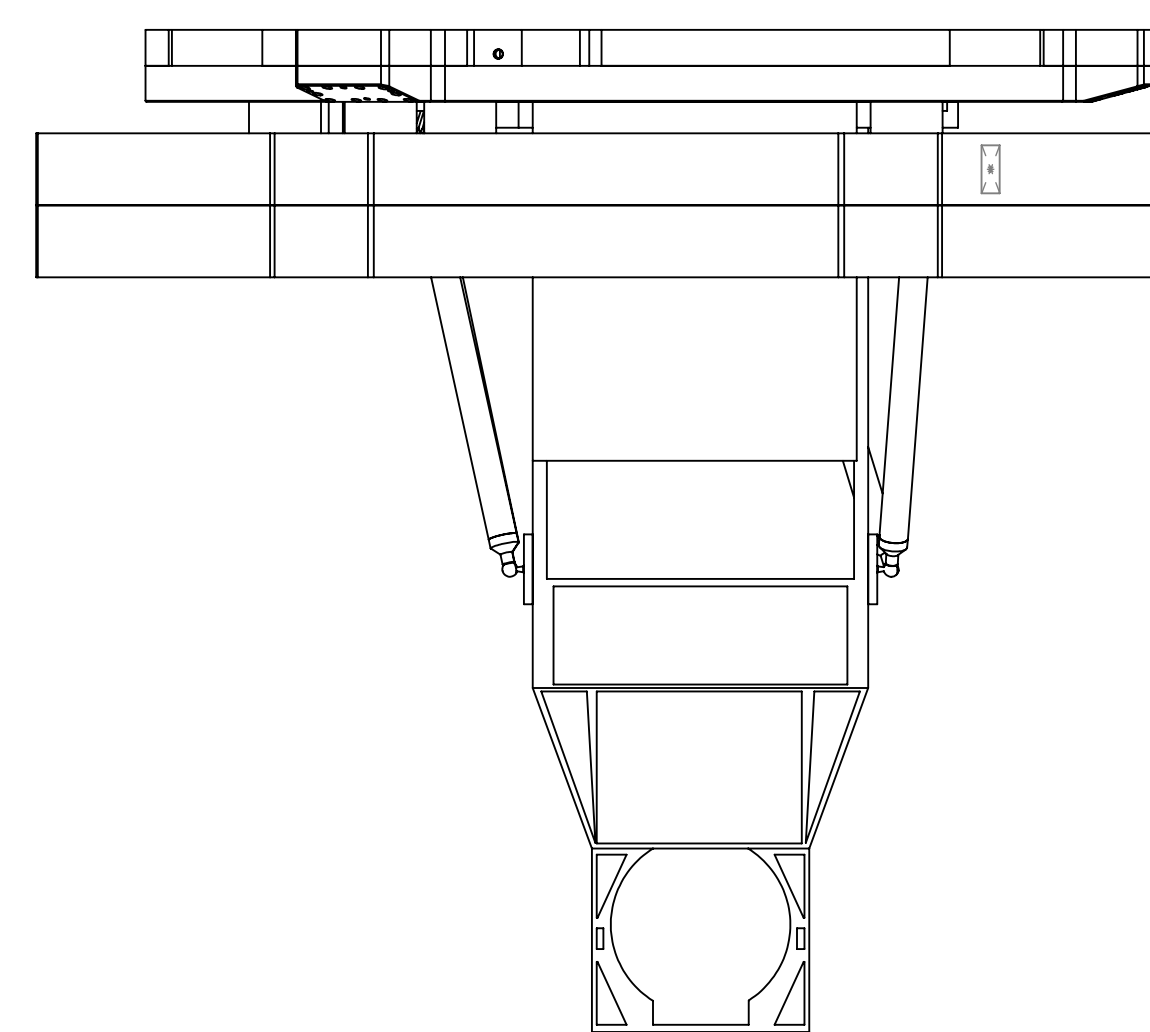

RIGHT SIDE VIEW

DATA TABLE IS FROM SUBCONFIGURATION
"MASS CALCULATION 1"

BSC5-H2	
CofG COORDINATES (mm)	
X	127.5
Y	1266.0
Z	91.2
TABLE MASS W/NO SUS-MASS TOTAL	549.17

NOTES AND TOLERANCES: (UNLESS OTHERWISE SPECIFIED)
 1. INTERPRET DRAWING PER ASME Y14.5-1994.
 2. REMOVE ALL SHARP EDGES, R.02 MIN.
 3. DO NOT SCALE FROM DRAWING.
 4. ALL MACHINING FLUIDS SHALL BE WATER SOLUBLE AND FREE OF SULFUR, CHLORINE AND SILICONE, SUCH AS CINCINNATI MILACRON'S CIMTECH 410.

DIMENSIONS ARE IN INCHES
 TOLERANCES:
 ±
 ±
 ± 0.5°

 --- μ inch

LIGO CALIFORNIA INSTITUTE OF TECHNOLOGY
 MASSACHUSETTS INSTITUTE OF TECHNOLOGY

ADVANCED LIGO SUB-SYSTEM
 SUS

NEXT ASSY

PART NAME
 BSC5-H2 Top Level Chamber Assembly, Simplified

ED CHAVEZ 15 SEPT 2009

SIZE DWG. NO. REV.
 D 1:24 PROJECTION: SHEET 3 OF 4

DDP00302 BSC5-H2 Top Level Chamber Assembly, Simplified-1.PART PDM REV: X.026. DPA-WING PDM REV: X.000

NOTES CONTINUED:
 5 Reference DCC # 1010074-02

REV.	DATE	DCN #	DRAWING TREE #
-	-	-	-
-	-	-	-
-	-	-	-

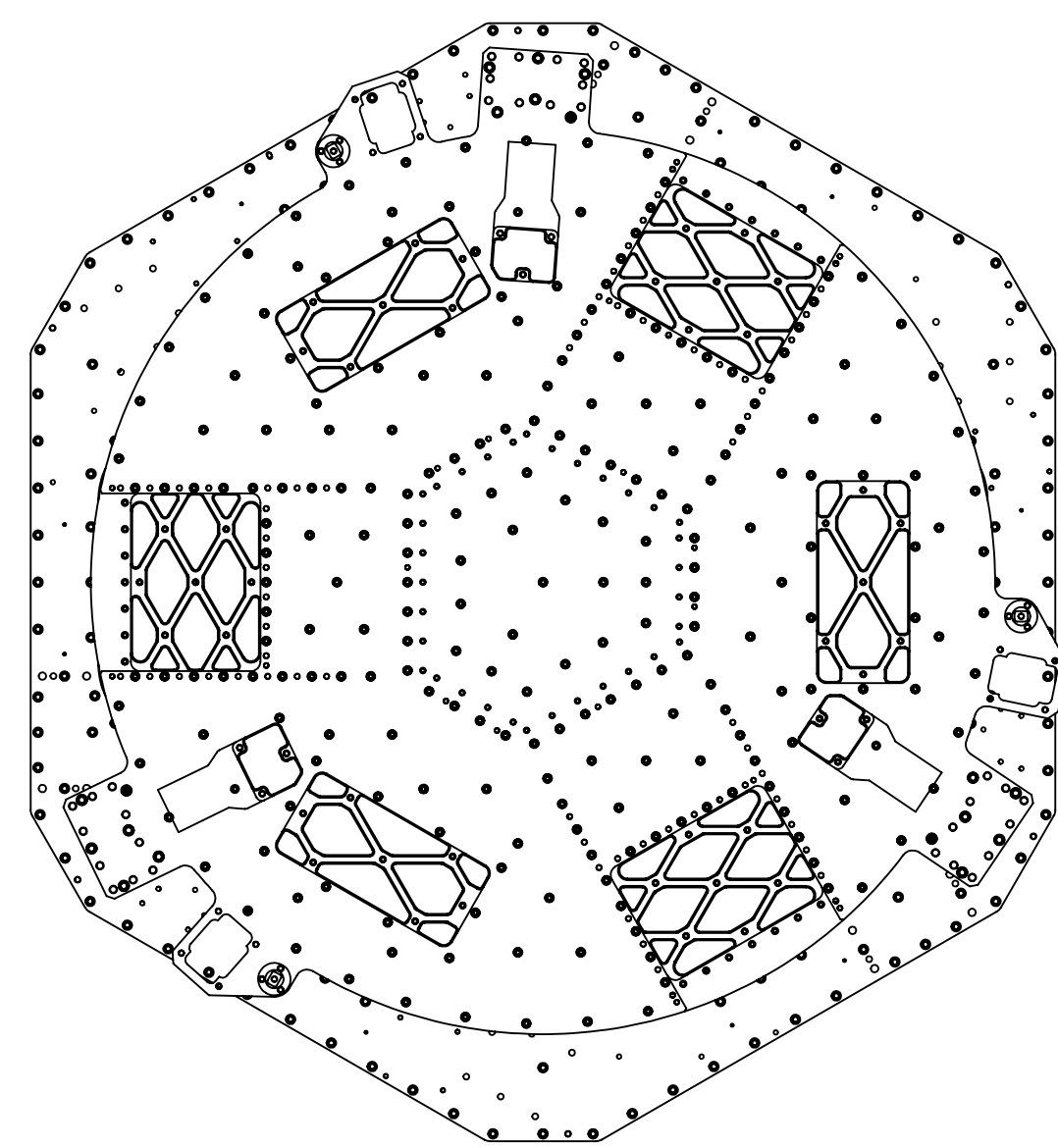

TOP VIEW

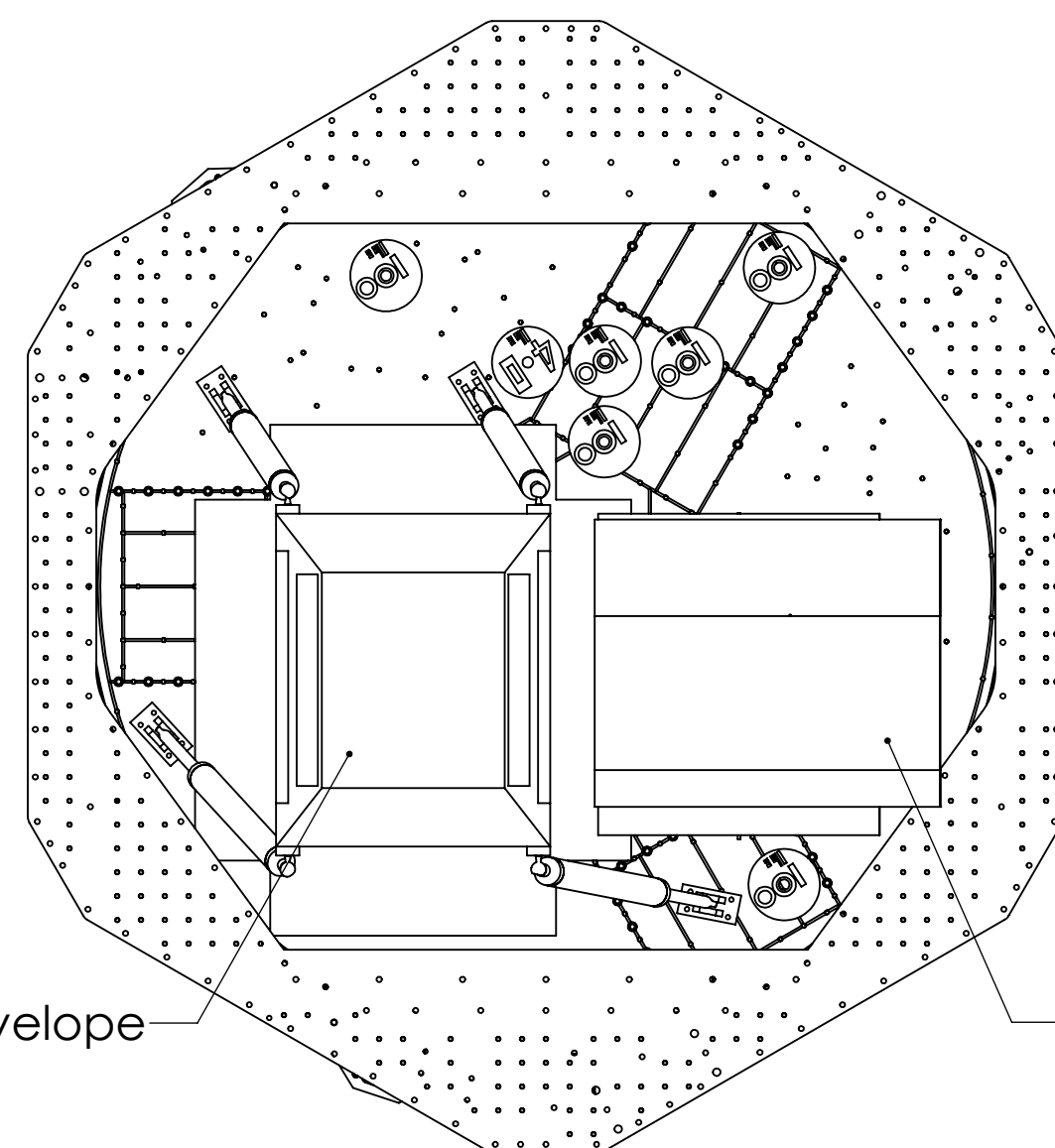

BOTTOM VIEW

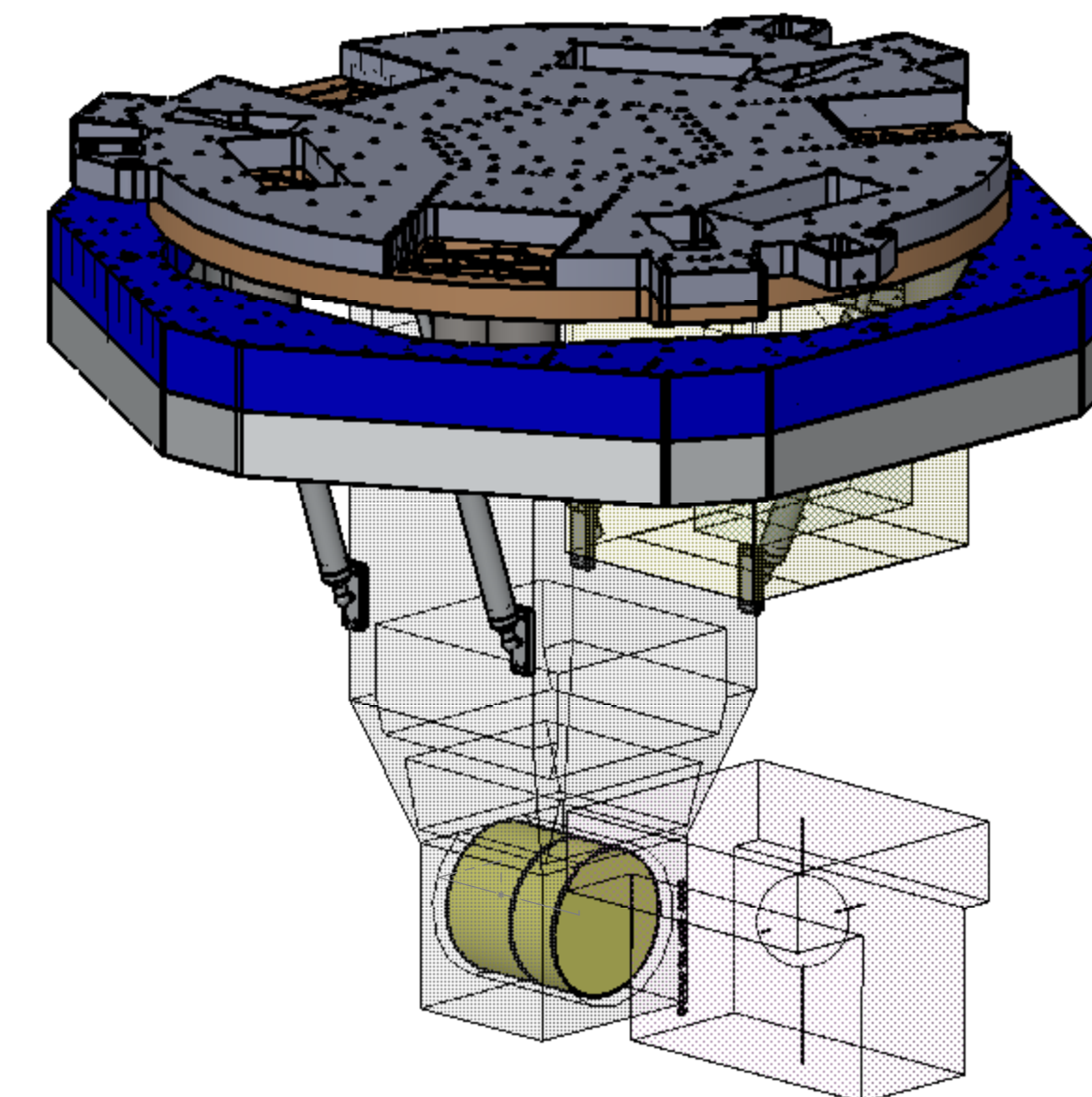
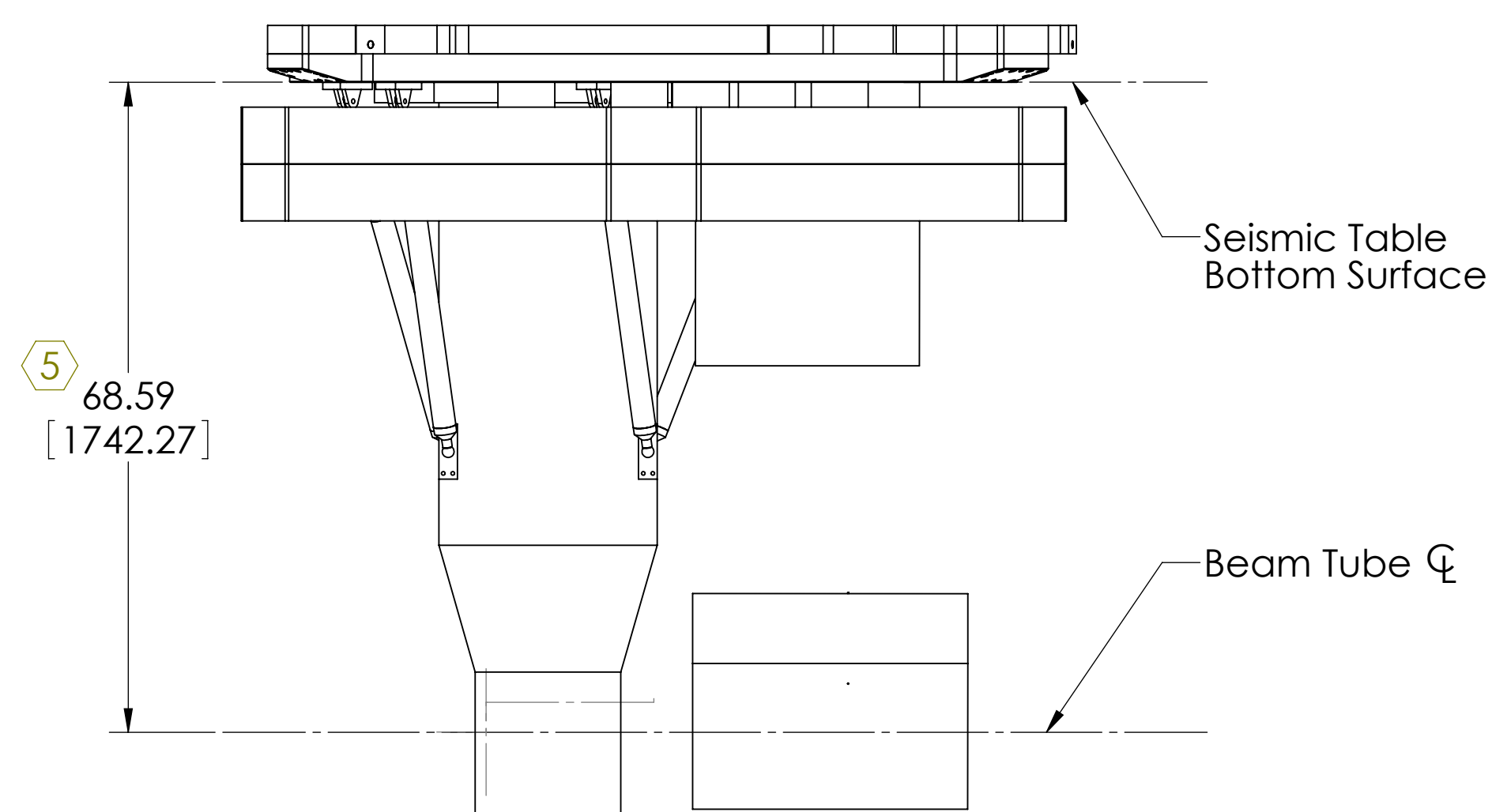
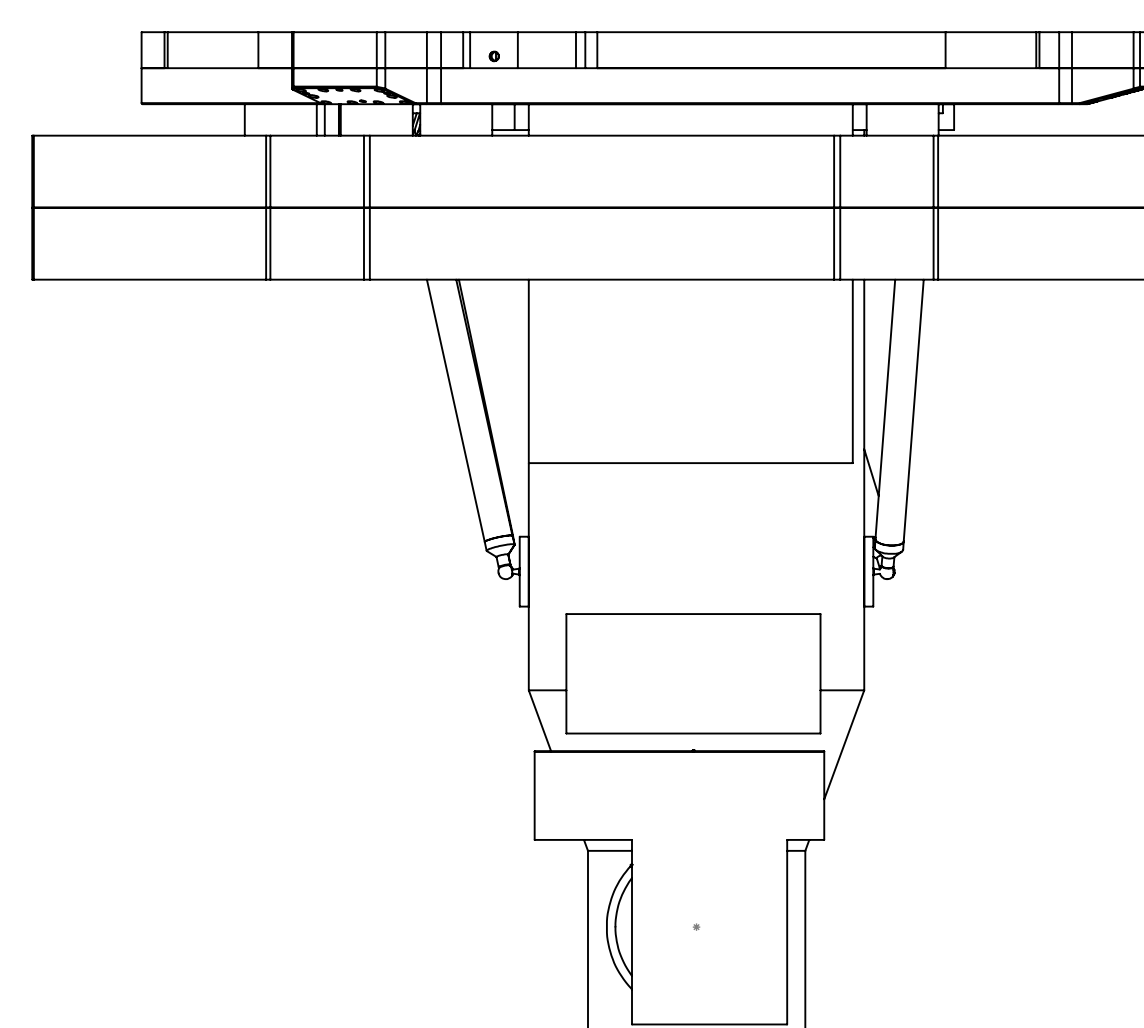

TABLE MASS TOTAL & NO CHAMBER SHOWN



FRONT VIEW



RIGHT SIDE VIEW

DATA TABLE IS FROM SUBCONFIGURATION "MASS CALCULATION 2"

BSC5-H2	
CofG COORDINATES (mm)	
X	-2.46
Y	1.58
Z	1030.00
TABLE MASS TOTAL	803.54

DIMENSIONS ARE IN INCHES

TOLERANCES:
 .XX ± 0.01
 .XXX ± 0.005

ANGULAR ± 0.5°

2. REMOVE ALL SHARP EDGES, R.02 MIN.
 3. DO NOT SCALE FROM DRAWING.
 4. ALL MACHINING FLUIDS SHALL BE WATER SOLUBLE AND FREE OF SULFUR, CHLORINE AND SILICONE, SUCH AS CINCINNATI MILACRON'S CIMTECH 410.

MATERIAL: -- FINISH: -- μinch

LIGO CALIFORNIA INSTITUTE OF TECHNOLOGY
 MASSACHUSETTS INSTITUTE OF TECHNOLOGY

SYSTEM: ADVANCED LIGO SUB-SYSTEM: SUS

NEXT ASSY

PART NAME: BSC5-H2 Top Level Chamber Assembly, Simplified

DESIGNER: ED CHAVEZ
 DRAFTER: ED CHAVEZ
 CHECKER:
 APPROVAL:
 SIZE: D DWG. NO.: D0900502
 SCALE: 1:24 PROJECTION: SHEET 4 OF 4

REV. v5

D0900502 BSC5-H2 Top Level Chamber Assembly, Simplified-IL PART PDM REV: X-026 DRAWING PDM REV: X-000