

REV.	DATE	DCH #	DRAWING TREE #
v11	02 APR 2013		
v12	08 MAY 2013	E1300401-x0	
v13	22 MAY 2013	E1300472-x0	

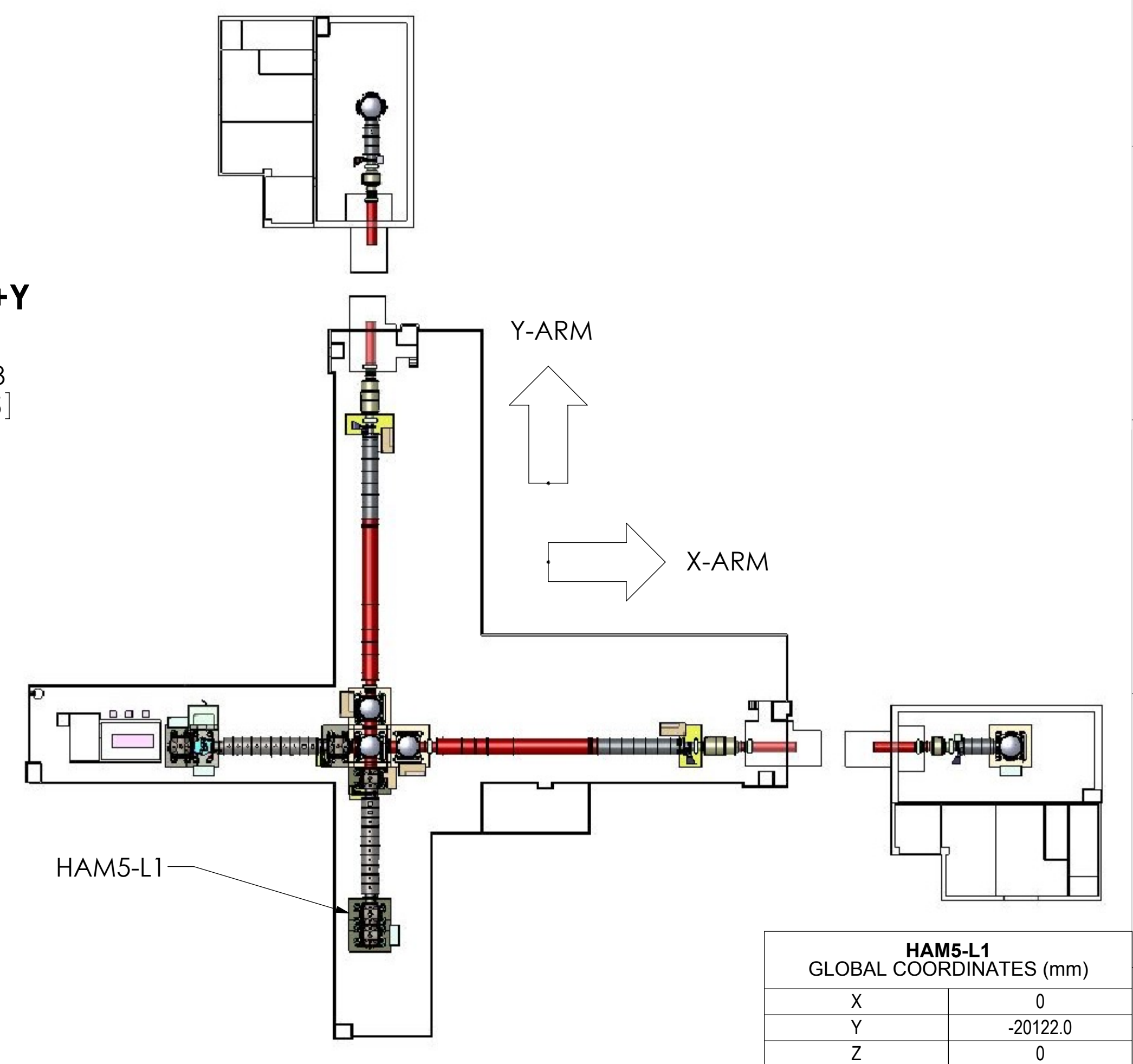
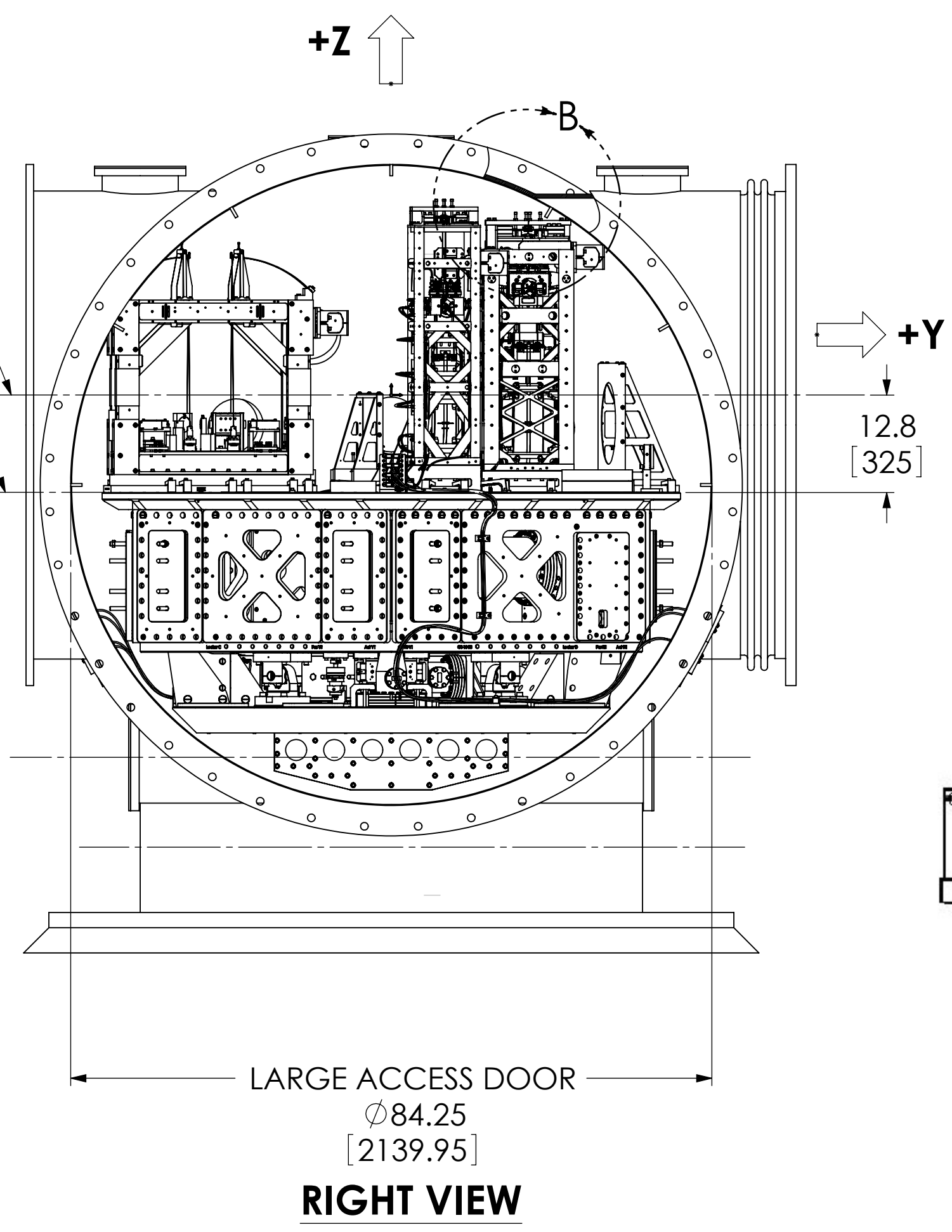
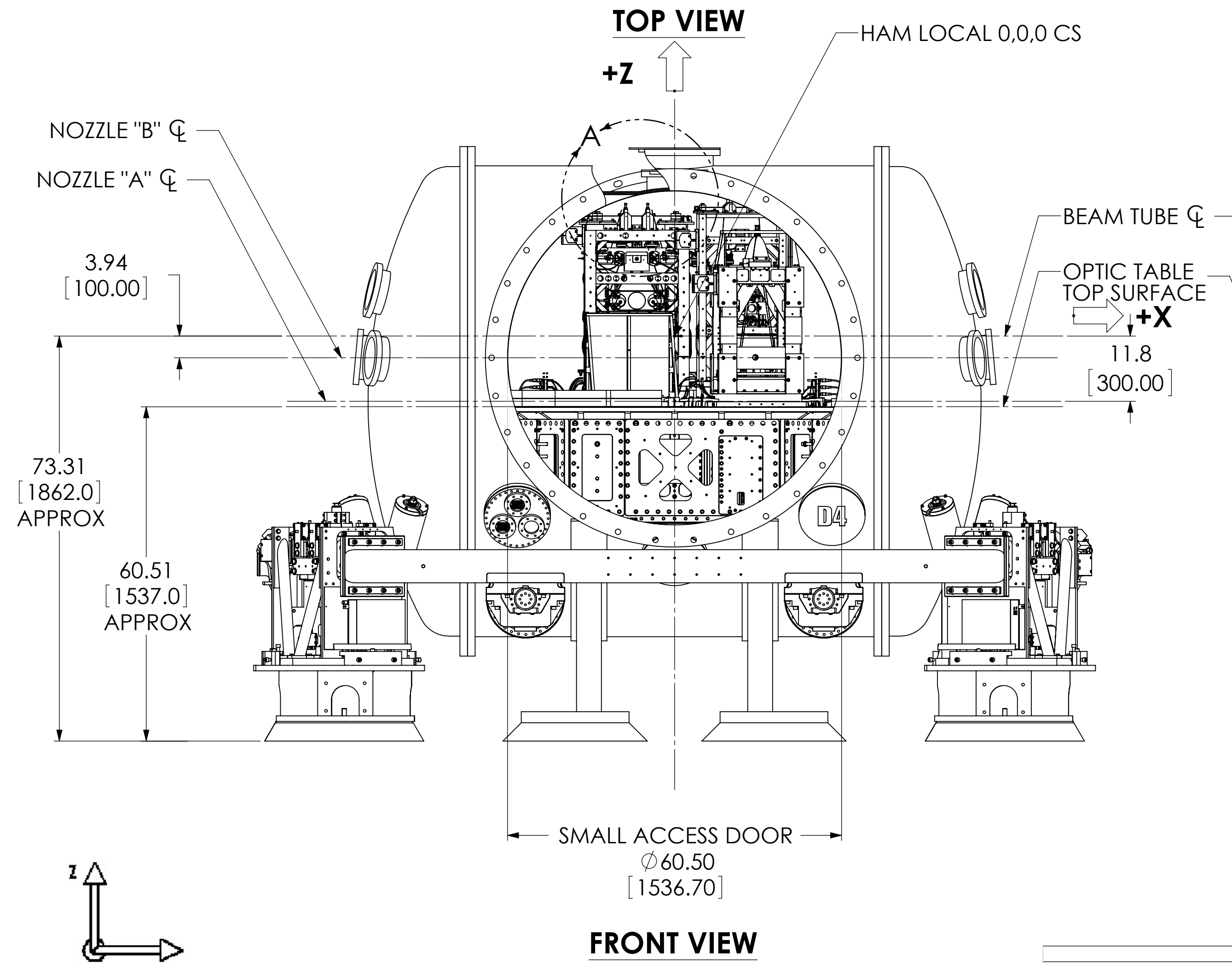
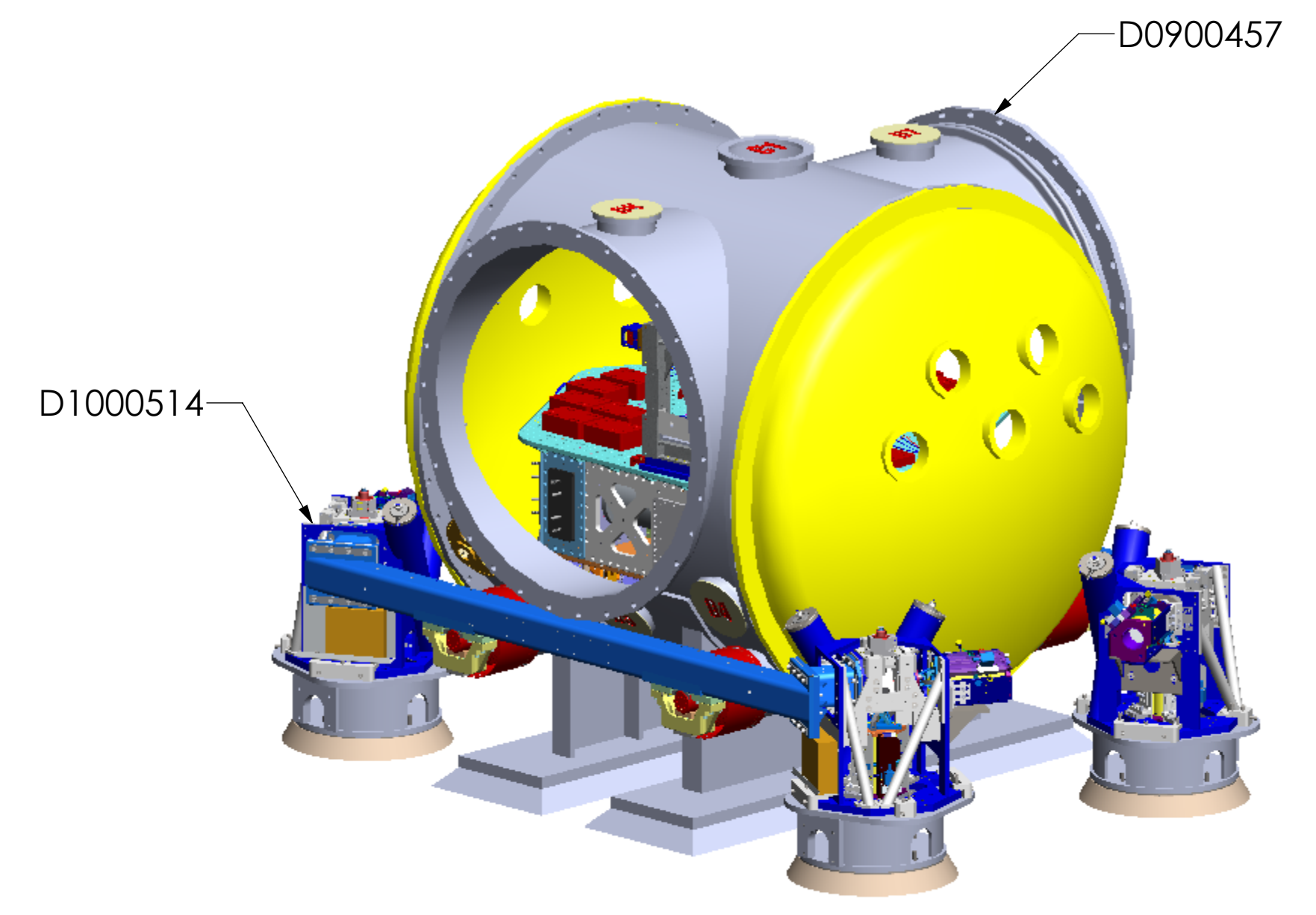
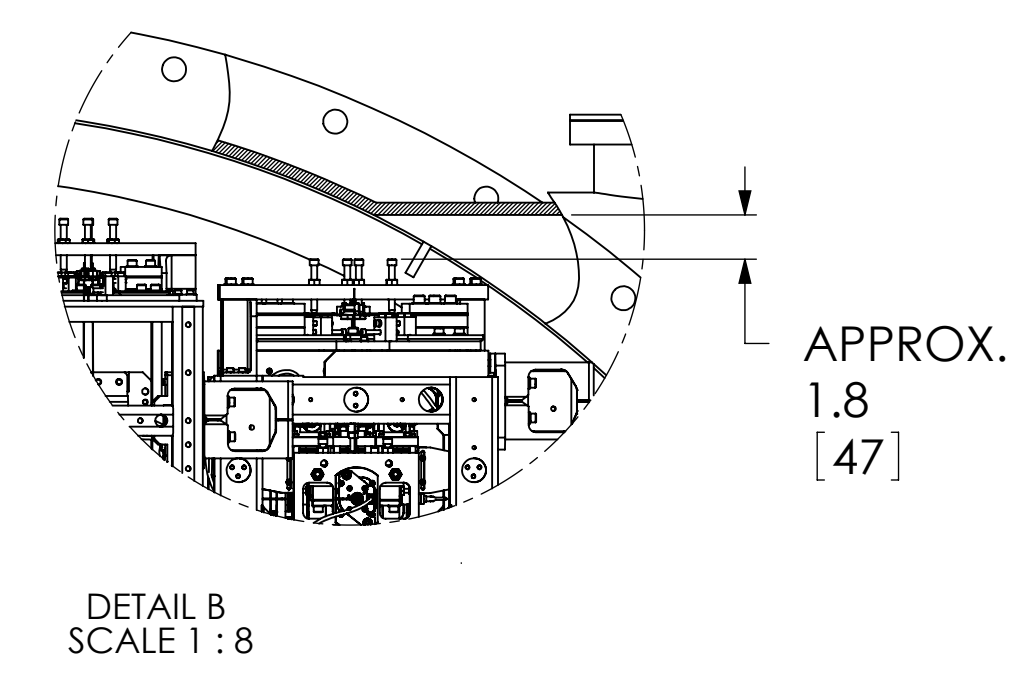
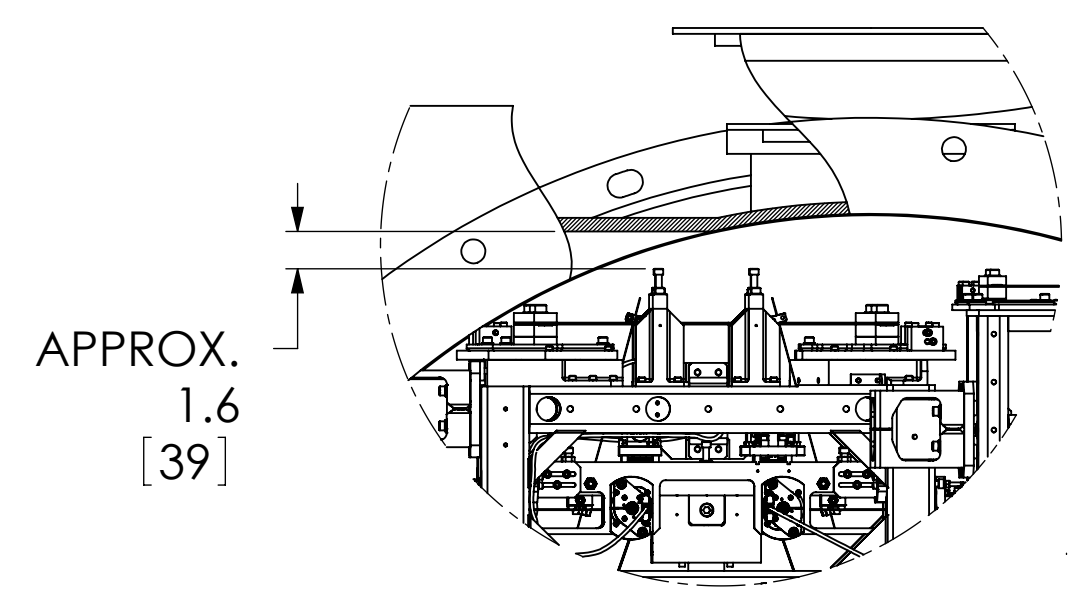
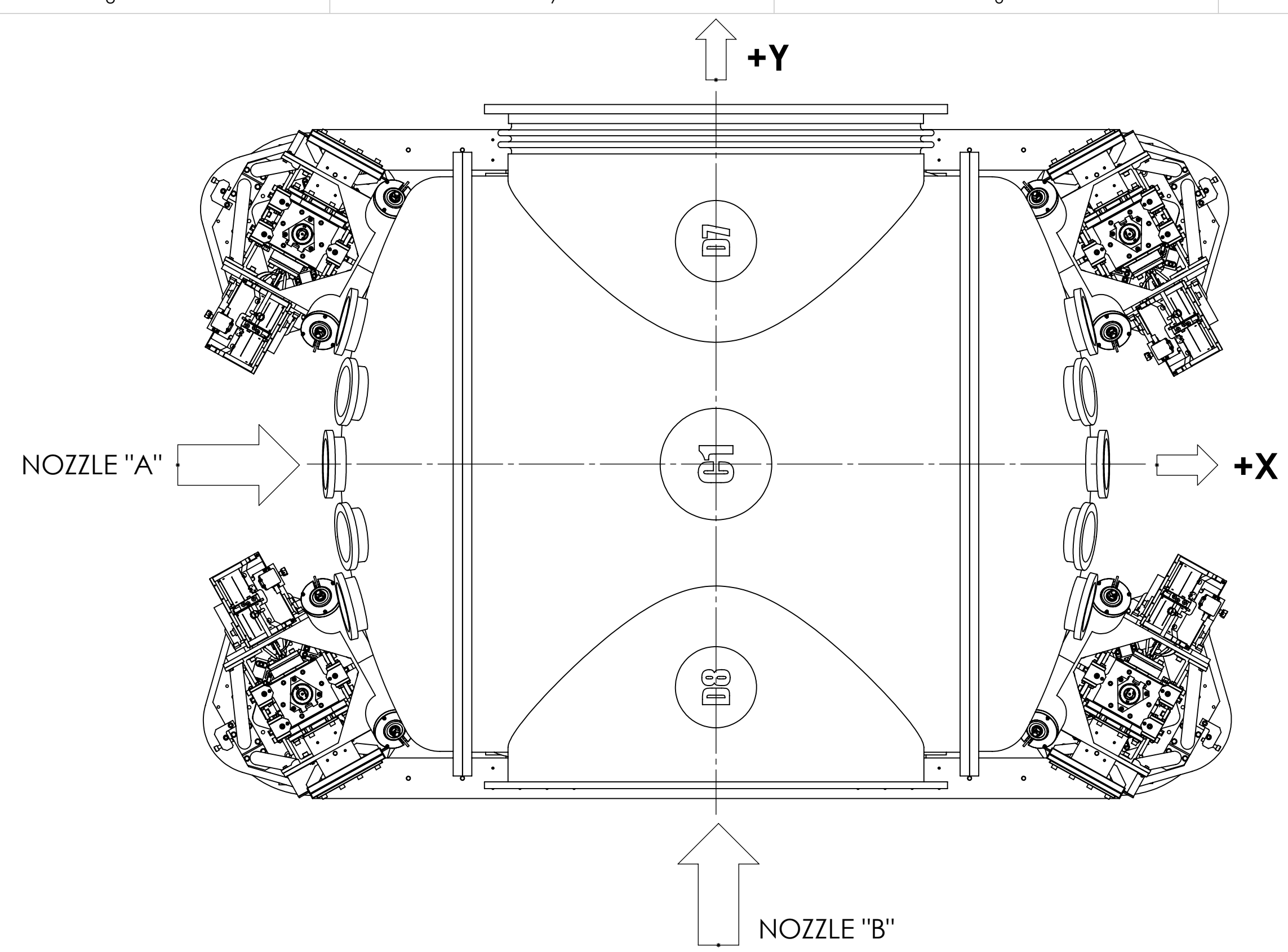

HAM5-L1 GLOBAL COORDINATES (mm)	
X	0
Y	-20122.0
Z	0

NOTES AND TOLERANCES: (UNLESS OTHERWISE SPECIFIED)

MATERIAL	--	FINISH	-- μ inch
----------	----	--------	---------------

CALIFORNIA INSTITUTE OF TECHNOLOGY MASSACHUSETTS INSTITUTE OF TECHNOLOGY		PART NAME	
SYSTEM		ADVANCED LIGO	
SUB-SYSTEM		SUS	
DESIGNER	ED CHAVEZ	27 JUL 2009	SIZE DWG. NO.
DRAFTER	C. TORRIE	15 NOV 2011	D
CHECKER	SEE DCC	SEE DCC	SCALE: 1:16
APPROVAL	SEE DCC	SEE DCC	PROJECTION:
HAM5-L1 TOP LEVEL CHAMBER ASSEMBLY, FULLY FINISHED			REV.
D0900456			v13
SHEET 1 OF 4			

D:\D0900456_A01\LIGO Systems\HAM5-L1 Top Level Chamber Assembly\ALL PART PDM REV. X-059 DRAWING PDM REV. X-012

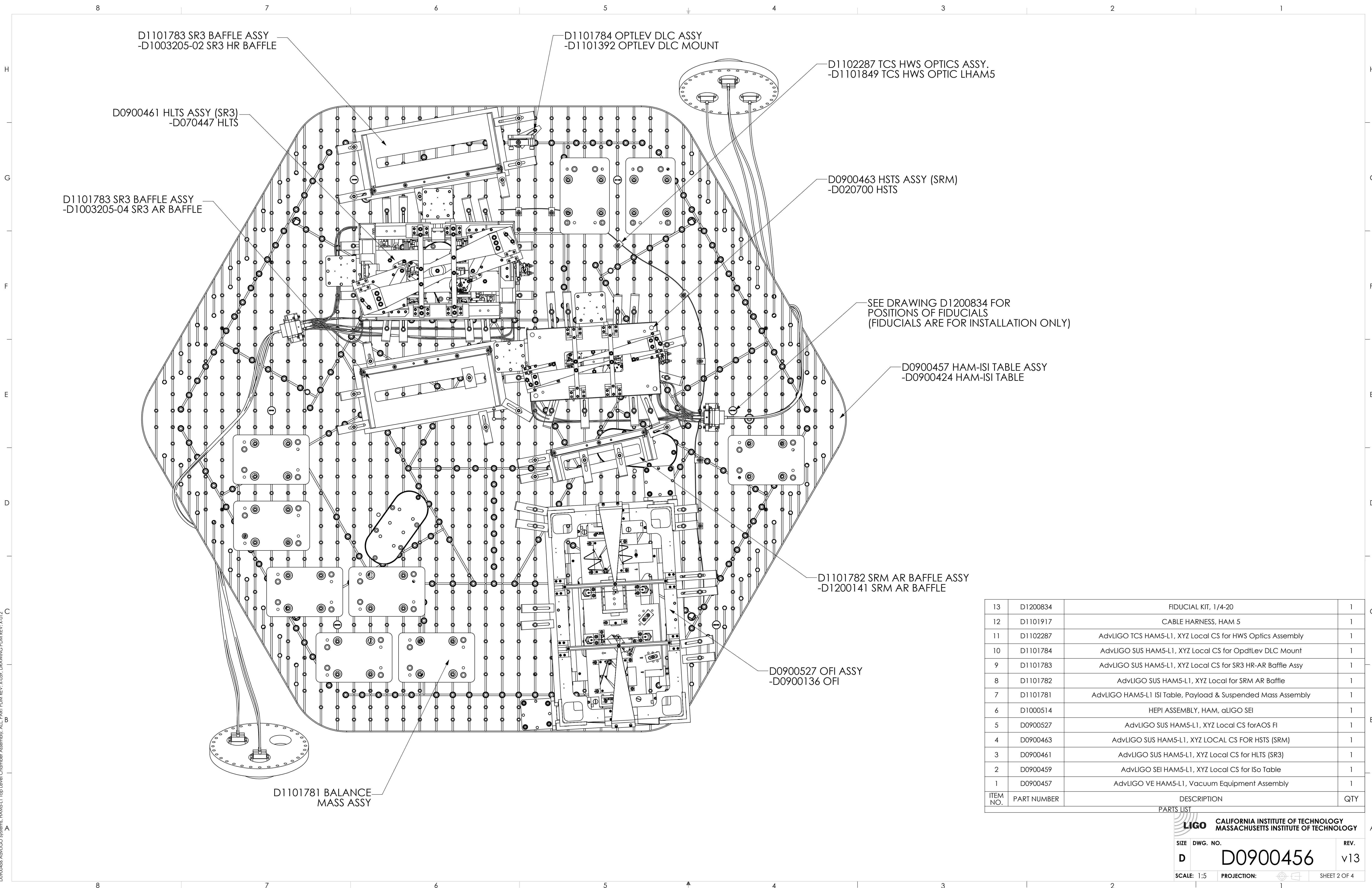

ITEM NO.	PART NUMBER	DESCRIPTION	QTY
13	D1200834	FIDUCIAL KIT, 1/4-20	1
12	D1101917	CABLE HARNESS, HAM 5	1
11	D1102287	AdvLIGO TCS HAM5-L1, XYZ Local CS for HWS Optics Assembly	1
10	D1101784	AdvLIGO SUS HAM5-L1, XYZ Local CS for OptLev DLC Mount	1
9	D1101783	AdvLIGO SUS HAM5-L1, XYZ Local CS for SR3 HR-AR Baffle Assy	1
8	D1101782	AdvLIGO SUS HAM5-L1, XYZ Local for SRM AR Baffle	1
7	D1101781	AdvLIGO HAM5-L1 ISI Table, Payload & Suspended Mass Assembly	1
6	D1000514	HEPI ASSEMBLY, HAM, aLIGO SEI	1
5	D0900527	AdvLIGO SUS HAM5-L1, XYZ Local CS for AOS FI	1
4	D0900463	AdvLIGO SUS HAM5-L1, XYZ LOCAL CS FOR HSTS (SRM)	1
3	D0900461	AdvLIGO SUS HAM5-L1, XYZ Local CS for HLTS (SR3)	1
2	D0900459	AdvLIGO SEI HAM5-L1, XYZ Local CS for ISo Table	1
1	D0900457	AdvLIGO VE HAM5-L1, Vacuum Equipment Assembly	1

LIGO CALIFORNIA INSTITUTE OF TECHNOLOGY
 MASSACHUSETTS INSTITUTE OF TECHNOLOGY

SIZE DWG. NO. REV.
 D D0900456 v13

SCALE: 1:5 PROJECTION: SHEET 2 OF 4

D0900457 AdvLIGO Systems: HAM5-L1 Top Level Chamber Assembly: ALL PART PDM REV: X-059: DRAWING PDM REV: X-012

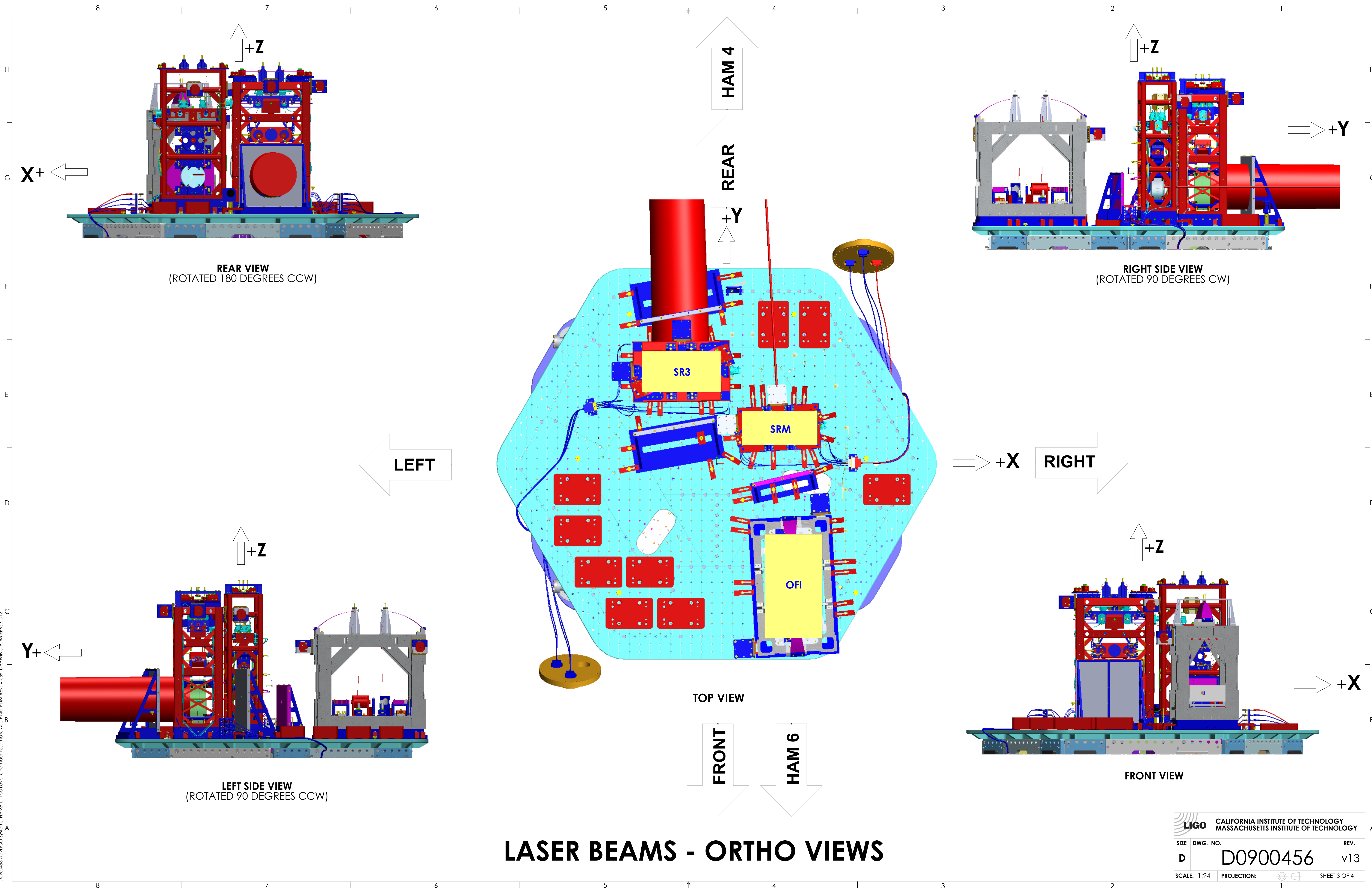

LASER BEAMS - ORTHO VIEWS

CALIFORNIA INSTITUTE OF TECHNOLOGY MASSACHUSETTS INSTITUTE OF TECHNOLOGY	
SIZE DWG. NO.	REV.
D D0900456	v13
SCALE: 1:24	PROJECTION:
SHEET 3 OF 4	

D:\D0900456_Ash\LIGO Systems_HAMS\1 Top Level Chamber Assembly_All Part PDM_REV_X-059_DRAWING PDM_REV_X-012

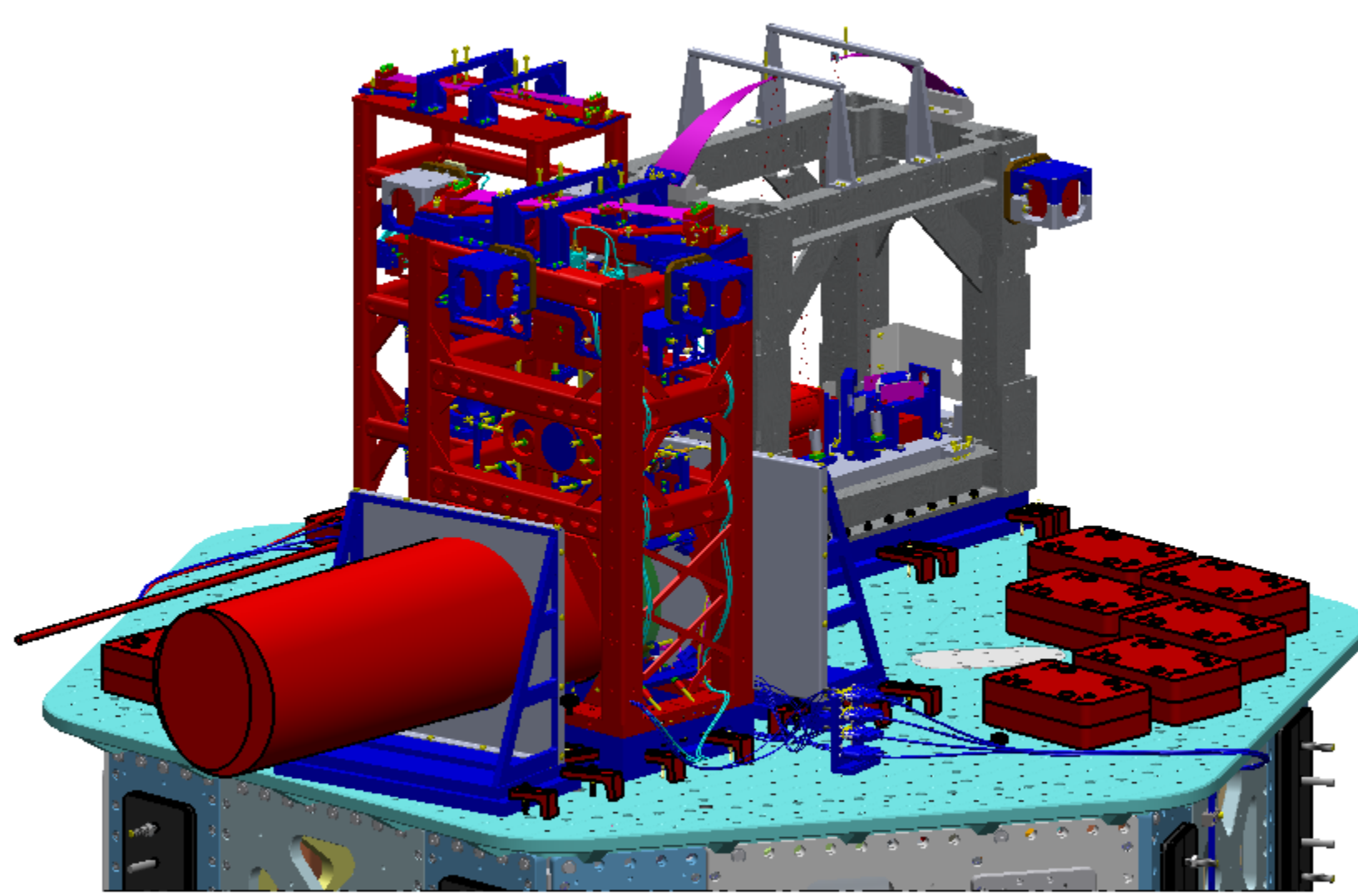

ISO REAR - LEFT

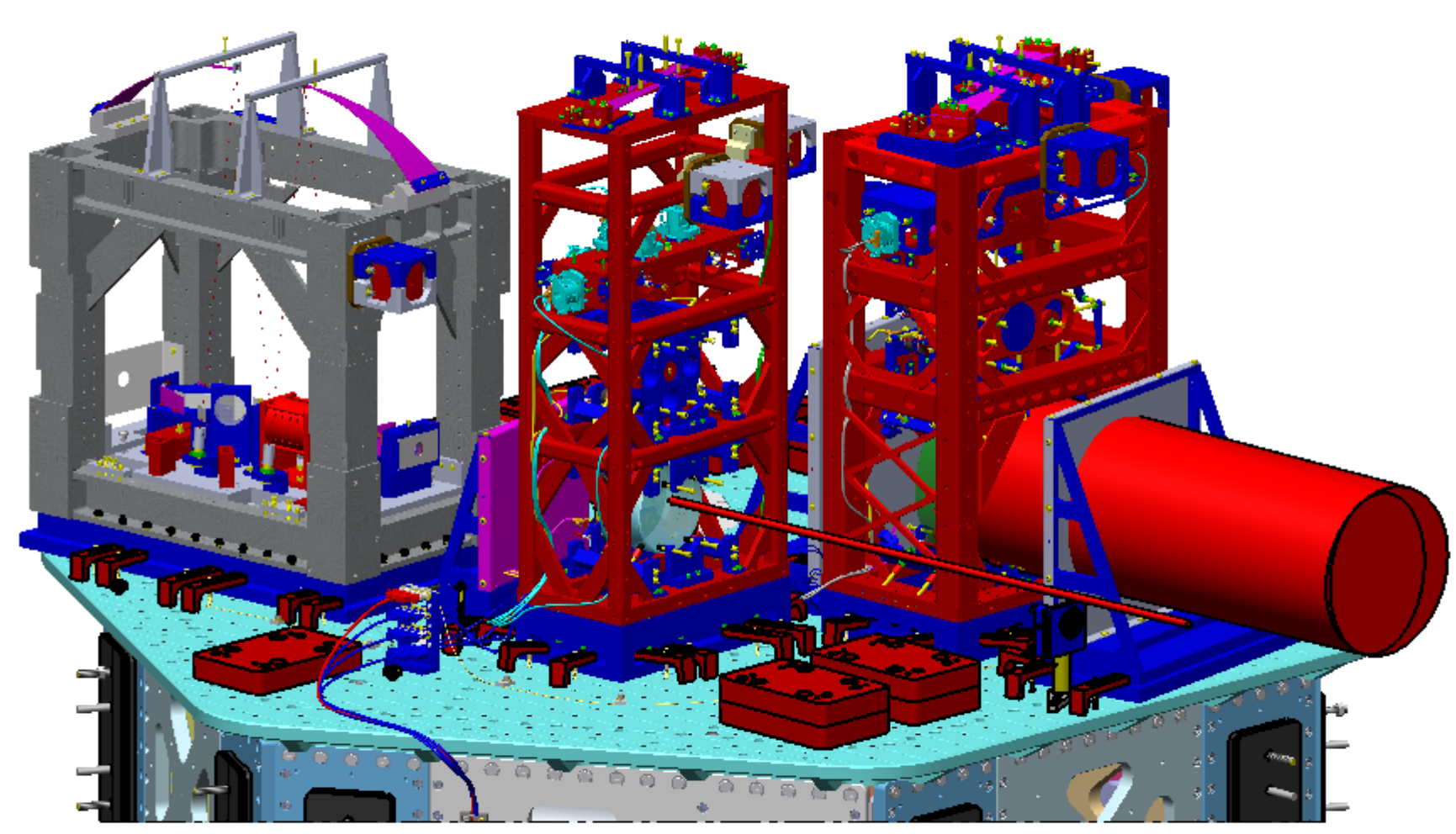

ISO REAR - RIGHT

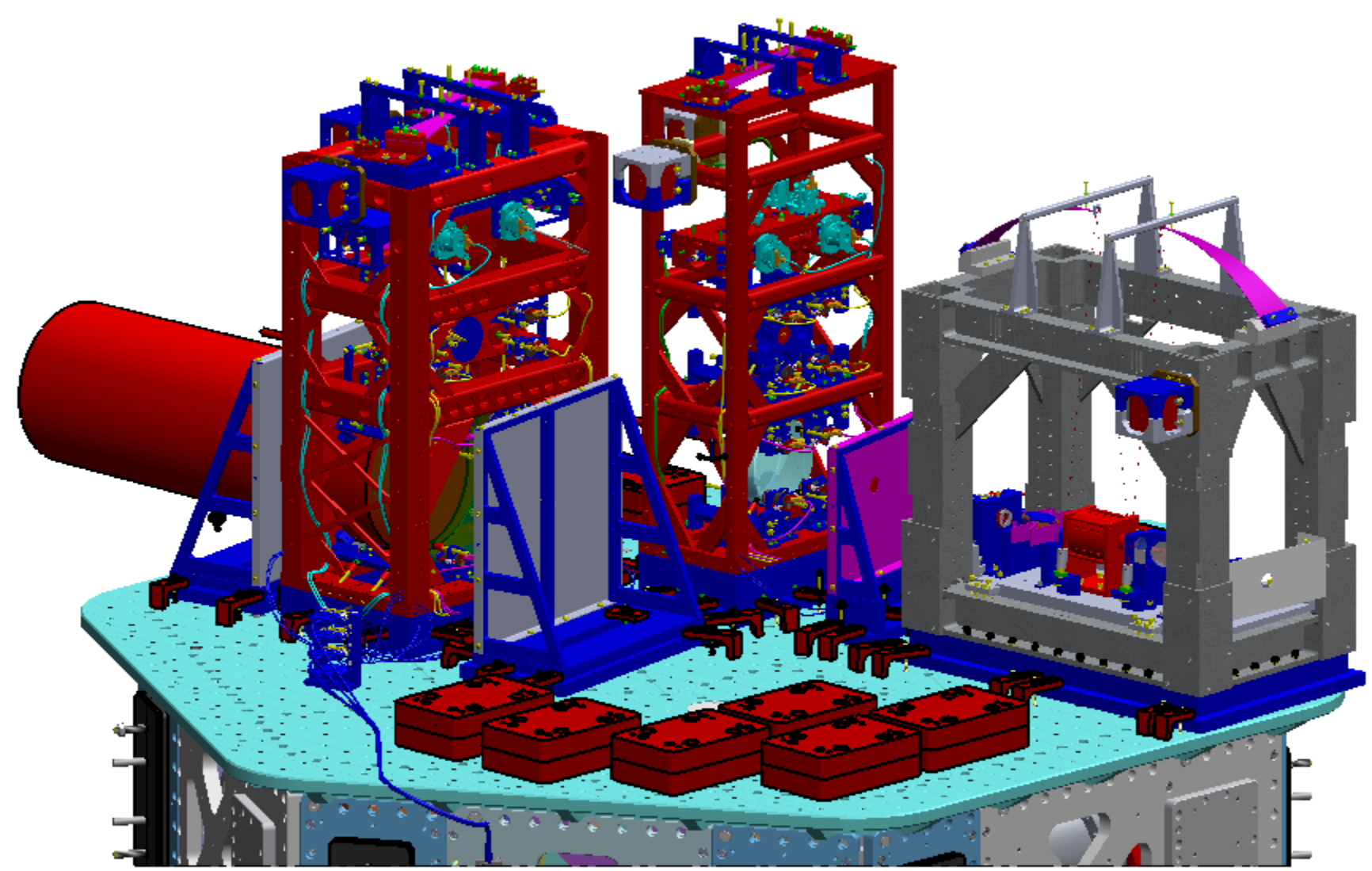

ISO FRONT - LEFT

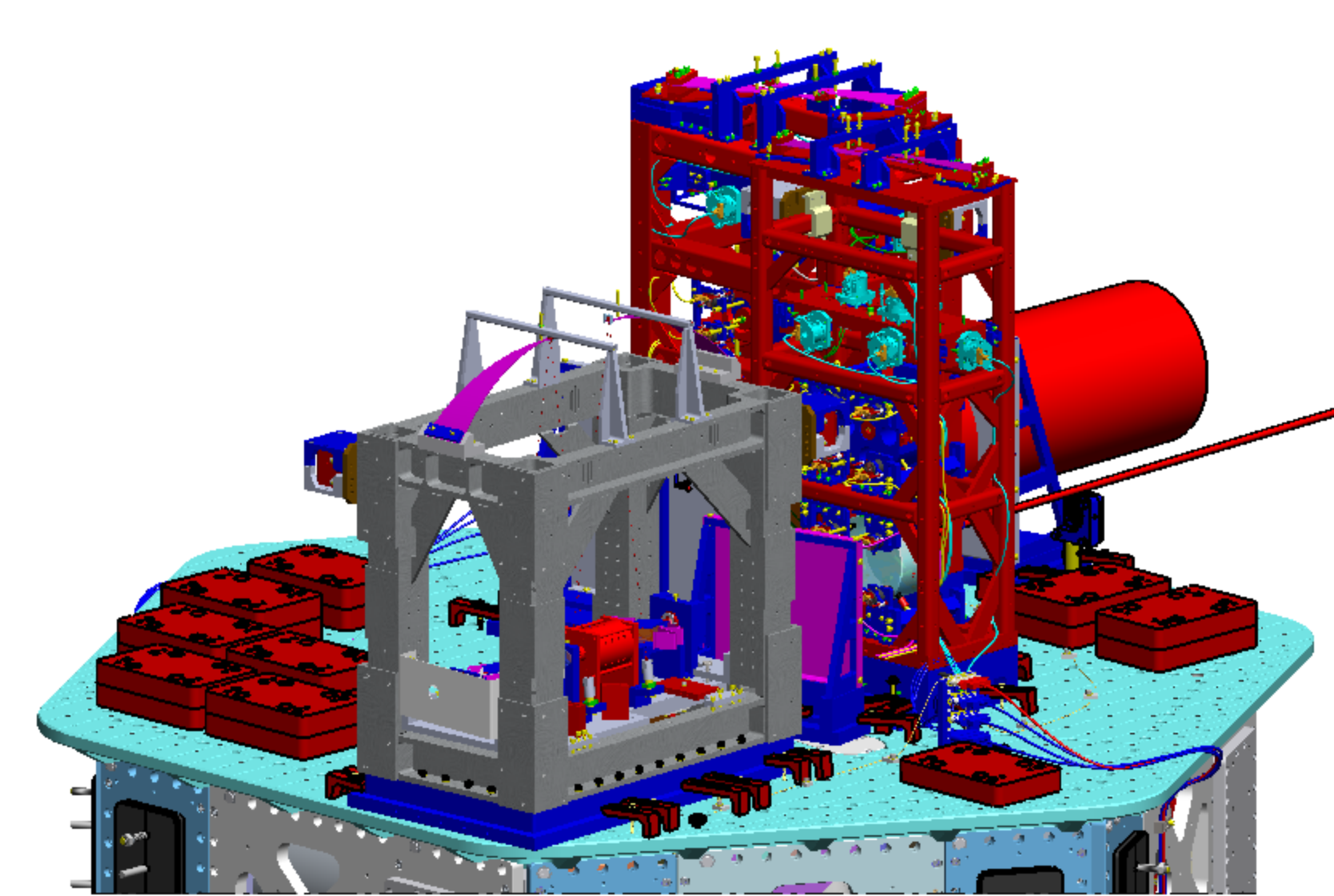

ISO FRONT - RIGHT

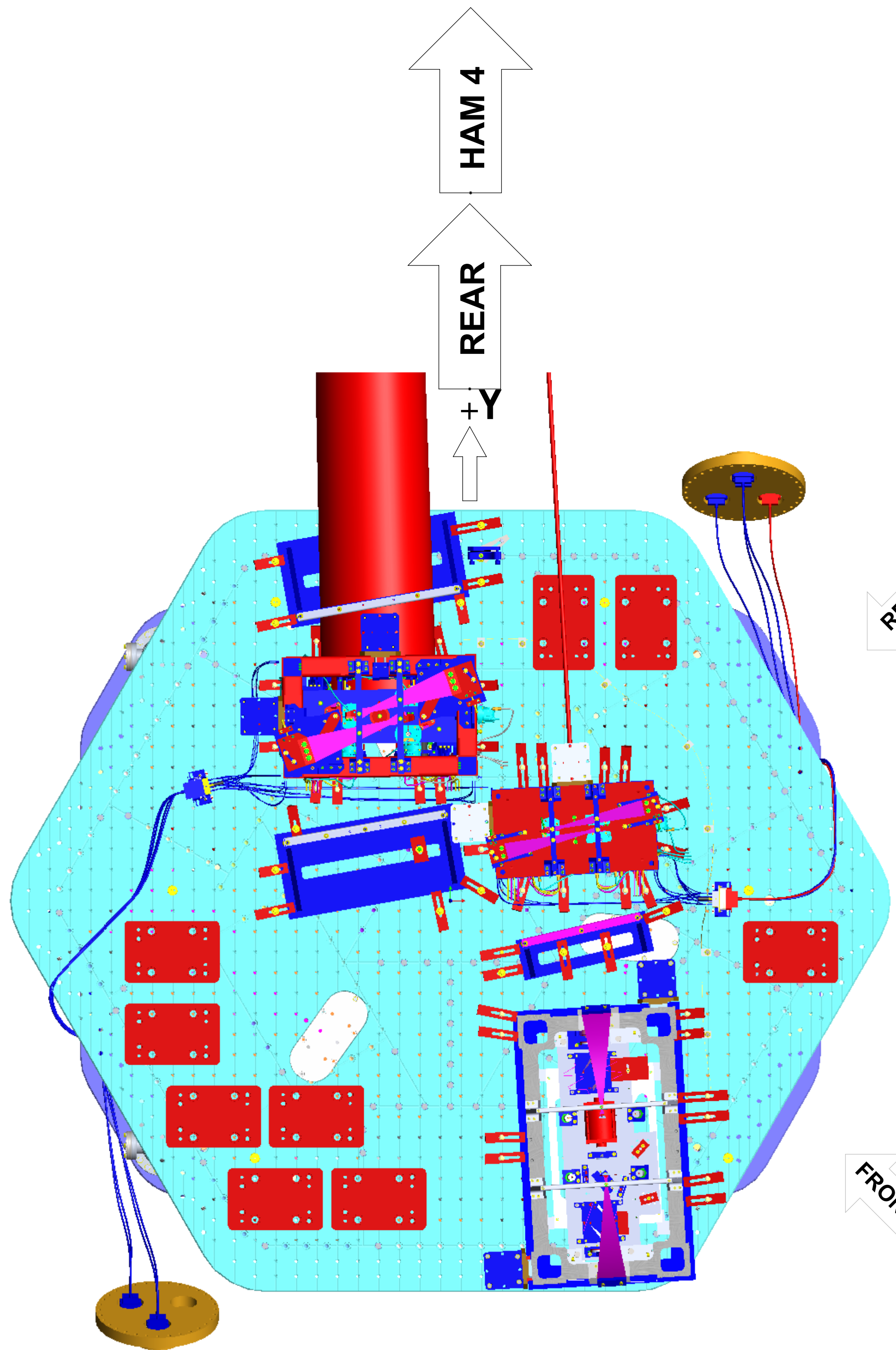

TOP VIEW

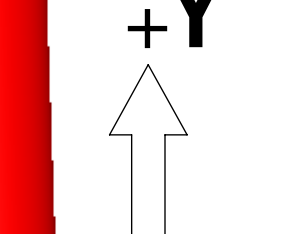
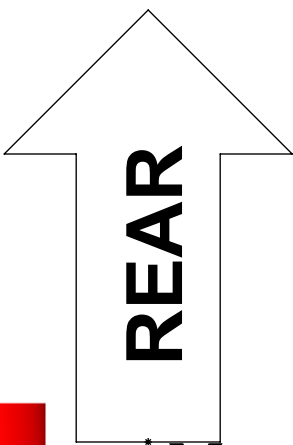
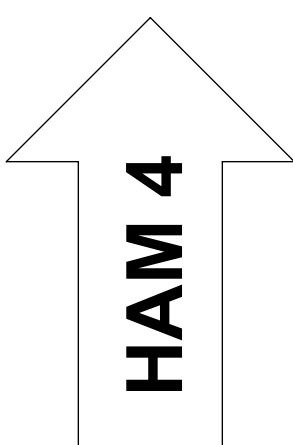
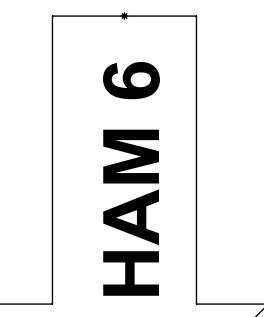
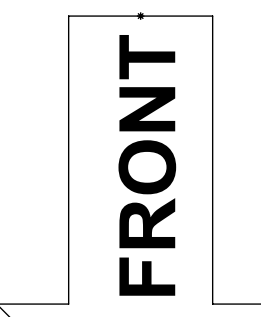
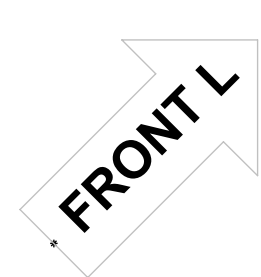
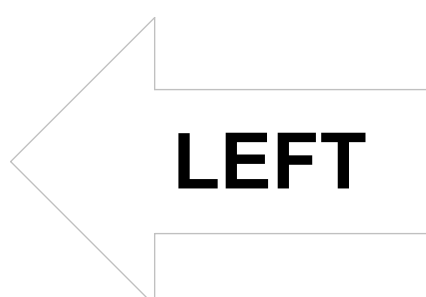
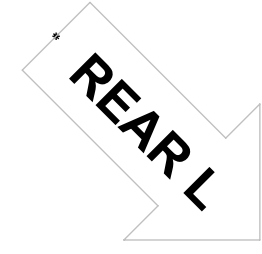

LASER BEAMS - ISO VIEWS

LIGO CALIFORNIA INSTITUTE OF TECHNOLOGY MASSACHUSETTS INSTITUTE OF TECHNOLOGY		REV.
SIZE DWG. NO.	D0900456	v13
SCALE: 1:24	PROJECTION:	SHEET 4 OF 4

DDP00456-AsstLIGO Systems: HAMS-L1 Top Level Chamber Assembly: ALL PART PDM REV: X-059 DRAWING PDM REV: X-012