

REV.	DATE	DCN #	DRAWING TREE #
B.	01/04/09.	E0900100.	.

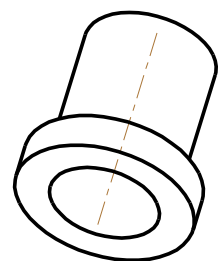
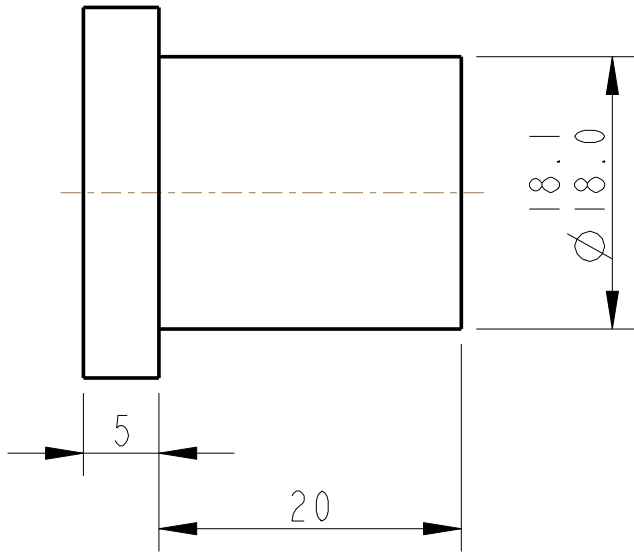
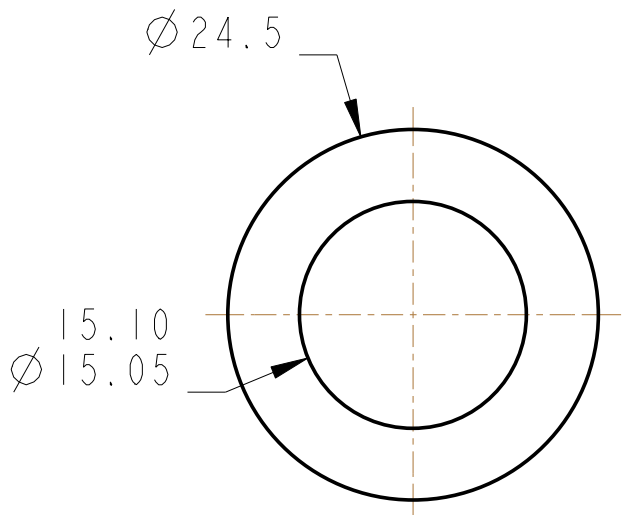

SCALE 1:1

ITEM	QTY	SPARE	TOTAL	PART NUMBER	DESCRIPTION	MATERIALS
------	-----	-------	-------	-------------	-------------	-----------

PARTS LIST

NOTES: (UNLESS OTHERWISE SPECIFIED)

<ol style="list-style-type: none"> REMOVE ALL SHARP EDGES, R.02 MIN. DO NOT SCALE FROM DRAWING. ALL MACHINING FLUIDS SHALL BE WATER SOLUBLE AND FREE OF SULFUR, CHLORINE AND SILICONE, SUCH AS CINCINNATI MILACRON'S CIMTECH 410 (STAINLESS STEEL) SCRIBE, ENGRAVE OR STAMP DRAWING PART NUMBER ON NOTED SURFACE OF PART AND A THREE DIGIT SERIAL NUMBER. SERIAL NUMBERS START AT 001 FOR THE FIRST PART AND PROCEED CONSECUTIVELY. USE .07" HIGH CHARACTERS. EXAMPLE: D020188- 001. A VIBRATORY TOOL MAY BE USED. 	<p>DIMENSIONS ARE IN mm [INCHES] TOLERANCES:</p> <p>X.XX ±0.2 mm ANGULAR ±0.25 °</p> <p>MATERIAL: PTFE</p> <p>FINISH: Ra = 1.6 √μm [μin]</p> <table border="1" style="width: 100%;"> <tr> <th>NAME</th> <th>DATE</th> </tr> <tr> <td>DRAWN A J BRUMM</td> <td>DB/12/08</td> </tr> <tr> <td>CHECKED J'OD</td> <td>--/--/--</td> </tr> <tr> <td>APPROVED AJB</td> <td>--/--/--</td> </tr> </table>	NAME	DATE	DRAWN A J BRUMM	DB/12/08	CHECKED J'OD	--/--/--	APPROVED AJB	--/--/--
NAME	DATE								
DRAWN A J BRUMM	DB/12/08								
CHECKED J'OD	--/--/--								
APPROVED AJB	--/--/--								

LIGO CALIFORNIA INSTITUTE OF TECHNOLOGY
MASSACHUSETTS INSTITUTE OF TECHNOLOGY
1GR, GLASGOW UNIVERSITY GEO 600 GROUP
RUTHERFORD APPLETON LABORATORIES

SYSTEM **ADVANCED LIGO**

SUB-SYSTEM **SUS**

NEXT ASSY **THIS**

PART NAME **BUSH**
TOP STAGE TOOLING

SIZE **A**

DRG. NO. **D080748**

SCALE 2:1 PROJECTION:

REV **B.**

SHEET 1 OF 1