

NOTES CONTINUED:

Ⓢ BAG ALL ITEMS INDIVIDUALLY AND TAG EACH BAG WITH THE PART NUMBER, REVISION, AND QUANTITY. EXAMPLE: DXXXXXX-VY, QTY: TBD.

REV.	DATE	DCN #	DRAWING TREE #
V1	3 MAR 2009	E0900066	E080191
-	-	-	-
-	-	-	-

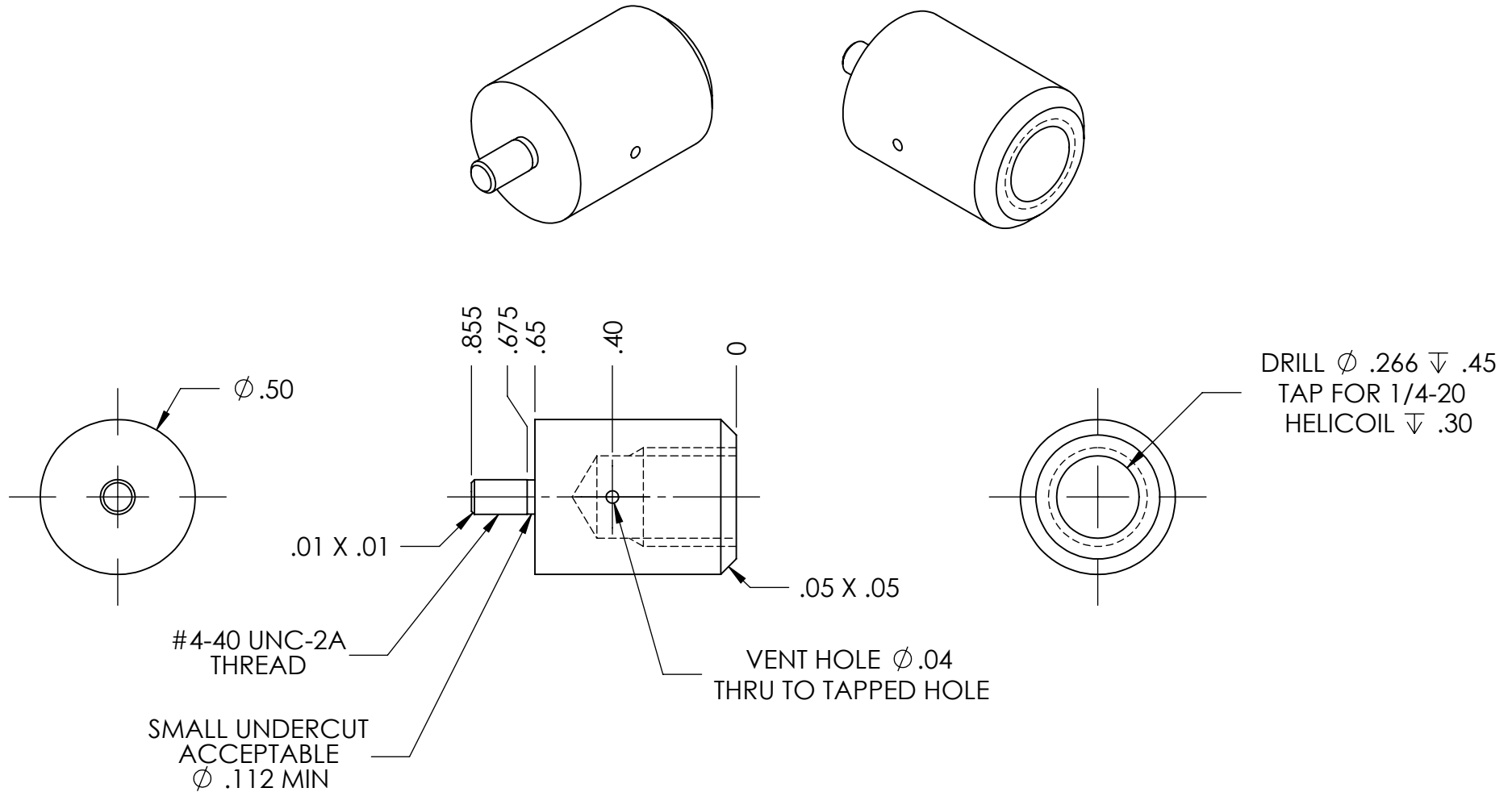

NOTES AND TOLERANCES: (UNLESS OTHERWISE SPECIFIED)

DIMENSIONS ARE IN INCHES

TOLERANCES:
 .XX $\pm .01$
 .XXX $\pm .005$

ANGULAR $\pm 0.5^\circ$

1. INTERPRET DRAWING PER ASME Y14.5-1994.
2. REMOVE ALL SHARP EDGES, R.02 MIN.
3. DO NOT SCALE FROM DRAWING.
4. ALL MACHINING FLUIDS SHALL BE WATER SOLUBLE AND FREE OF SULFUR, CHLORINE AND SILICONE, SUCH AS CINCINNATI MILACRON'S CIMTECH 410.

MATERIAL
 304, 316 OR 302 SSSL

FINISH
 63 μ inch



SYSTEM
 ADVANCED LIGO

SUB-SYSTEM
 SUS

NEXT ASSY
 EQ STOP FOR METAL/GLASS

PART NAME
 MOUNTING CAP, EARTHQUAKE STOP

DESIGNER	D. BRIDGES	12 NOV 2008	SIZE	DWG. NO.	REV.
DRAFTER	D. BRIDGES	16 APR 2009	A	D080724	v1
CHECKER	M. MEYER	16 APR 2009	SCALE: 2:1		PROJECTION:
APPROVAL			SHEET 1 OF 1		