

- NOTES CONTINUED:
- 5) SCRIBE, ENGRAVE OR MECHANICALLY STAMP (NO INKS OR DYES) DRAWING PART NUMBER, REVISION (AND VARIANT OR TYPE IF APPLICABLE) ON NOTED SURFACE OF PART FOLLOWED ON THE NEXT LINE WITH A THREE DIGIT SERIAL NUMBER. SERIAL NUMBERS START AT 001 FOR THE FIRST ARTICLE AND PROCEED CONSECUTIVELY. USE MINIMUM 0.12" HIGH CHARACTERS. UNLESS THE SIZE OF THE PART DICTATES SMALLER CHARACTERS, A VIBRATORY TOOL MAY BE USED. EXAMPLE: DXXXXXX-VY TYPE XX S/N XXX
  - 6) ALL SURFACES OF ALL PARTS ARE TO BE MACHINED AND AS RECEIVED, AS ROLLED, AS WELDED SURFACES WILL BE ACCEPTED, EXCEPT INNER SURFACES AND OUTER RADII OF TUBING. NO GRINDING OR LAPING WITH ABRASIVE WHEELS, CLOTH OR STONES IS PERMITTED. NO PARTS SHALL BE CAST OR MOLDED (NO TOOLING PLATE IS PERMITTED). BLANCHARD GRINDING IS ACCEPTABLE IF ALL GROUND SURFACES ARE MACHINED AFTERWARDS.
  - 7) ALL WELDING SHALL BE PERFORMED IN ACCORDANCE WITH LIGO SPECIFICATION EDP000048.
  - 8) TUBING IS 2.00" SQUARE WITH WALL THICKNESS OF .12" ± .01".
  - 9) TUBING IS 2.00" SQUARE WITH WALL THICKNESS OF .188" ± .01".
  - 10) AFTER WELDING, STRESS RELIEF AND HEAT TREATMENT FLY-CUT INDICATED SURFACE TO MEET REQUIRED DIMENSION.
  - 11) INDICATED FEATURES ARE TO BE ADDED AFTER ALL WELDING, HEAT TREATMENT AND ALL OTHER MACHINING OPERATIONS, INCLUDING FLY-CUTTING, ARE COMPLETED.
  - 12) SCRIBE LINE WHERE INDICATED. LINE SHOULD BE .04" WIDE X .02" DEEP AND RUN THE LENGTH OF THE FACE AS SHOWN.
  - 13) HOLE THROUGH OUTER WALL OF TUBE ONLY.
  - 14) HOLE THROUGH BOTH WALLS OF TUBE.
  - 15) HOLE THROUGH INNER WALL OF TUBE ONLY.
  - 16) ALL HELICOIL HOLES TO BE PREPARED IN ACCORDANCE WITH EMHART HELICOIL PRODUCT CATALOG, HC2000, REV. 4.
  - 17) ALL HELICOILS TO BE INSTALLED BY LIGO PERSONNEL AFTER DELIVERY, CLEANING AND BAKING OF FINISHED PARTS.

REV.	DATE	DCN #	DRAWING TREE #
v1	03 MAR 2009	E080446	E080191
v2	02 DEC 2009	E0900446	E080191
v3	-	INTERNAL REVISION	-
v4	29 AUG 2010	E1000371	E080191
v5	11 OCT 2010	E1000570	E080191
v6	11 JUN 2011	E1100527	E080191
v7	29 MAY 2012	E1200542	E080191

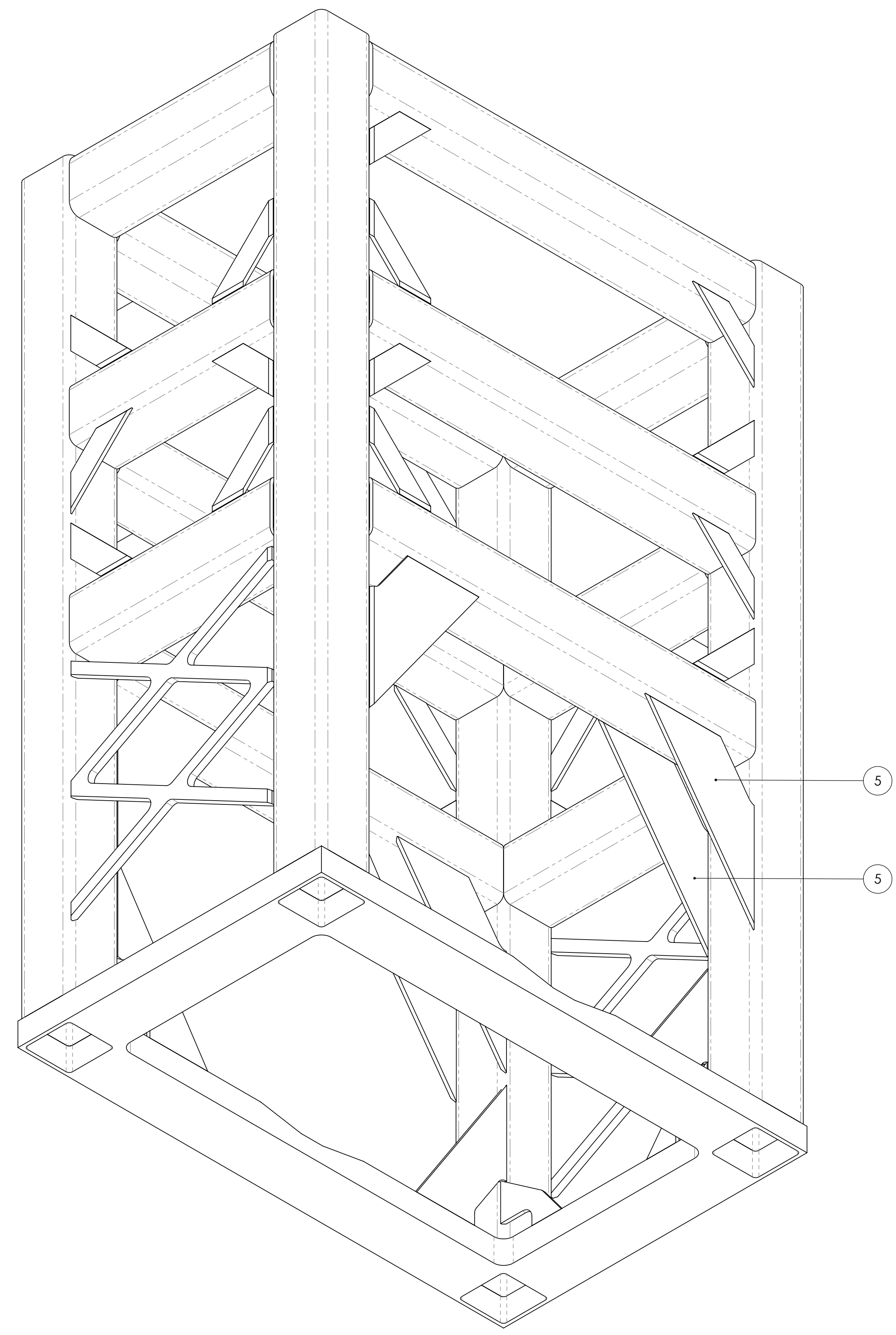
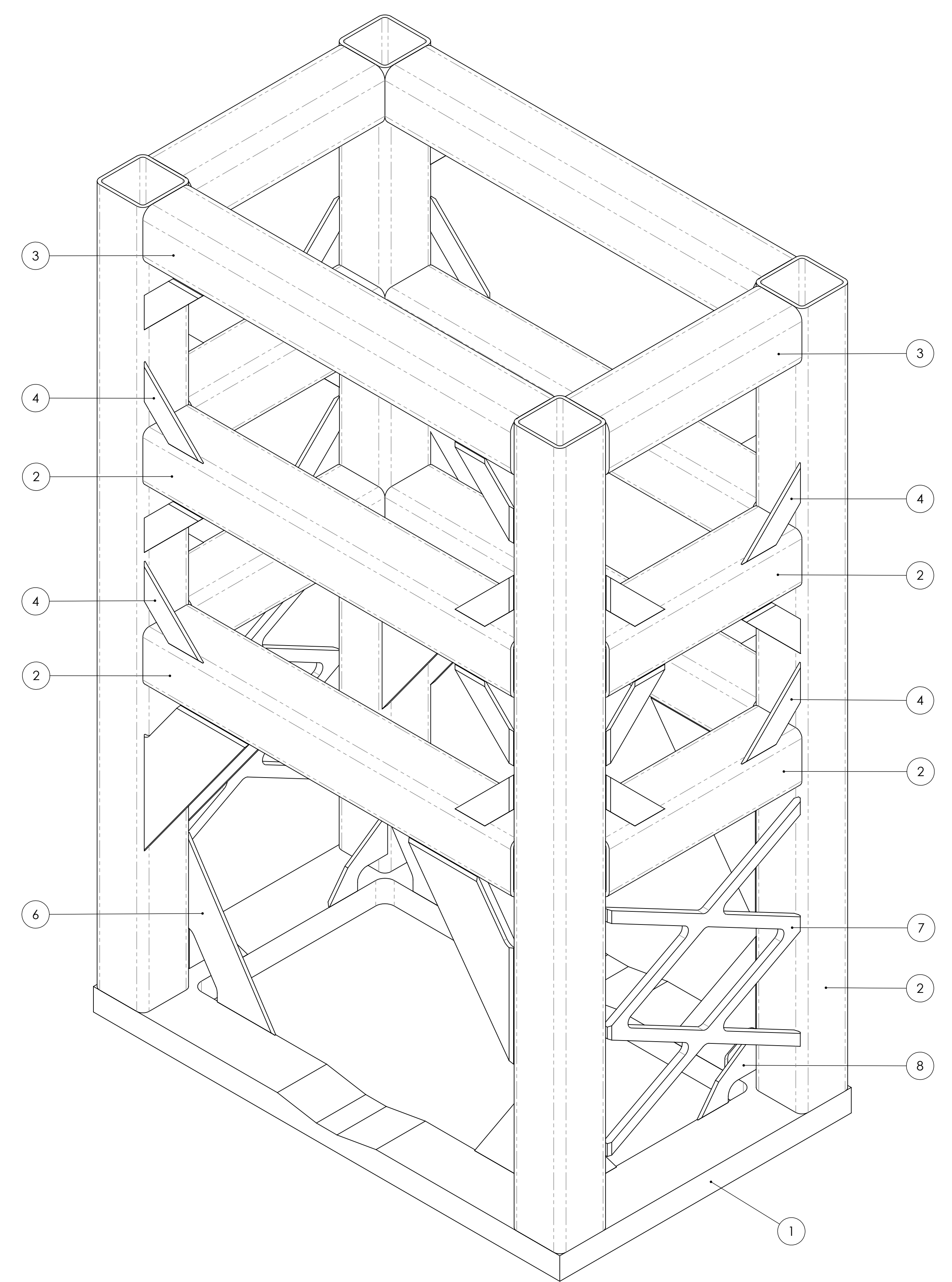

WELDMENT ISOMETRIC VIEWS

ITEM NO.	PART NUMBER	DESCRIPTION	TOTAL
8	D070577	SIDE GUSSET	4
7	D070578	SIDE STRUT	2
6	D070576	LOWER FRONT GUSSET	4
5	D070579	UPPER FRONT GUSSET	8
4	D070580	TOP GUSSET	28
3	-	2.00" SQUARE TUBE - .188" WALL THICKNESS (8)	-
2	-	2.00" SQUARE TUBE - .12" WALL THICKNESS (8)	-
1	D070575	BASE PLATE	1
PARTS LIST			TOTAL

NOTES AND TOLERANCES: (UNLESS OTHERWISE SPECIFIED) 1. INTERPRET DRAWING PER ASME Y14.5-1994. 2. REMOVE ALL SHARP EDGES, R.02 MIN. 3. DO NOT SCALE FROM DRAWING. 4. ALL MACHINING FLUIDS MUST BE FULLY SYNTHETIC, FULLY WATER SOLUBLE AND FREE OF SULFUR, SILICONE, AND CHLORINE.		<b>CALIFORNIA INSTITUTE OF TECHNOLOGY</b> <b>MASSACHUSETTS INSTITUTE OF TECHNOLOGY</b>		<b>STRUCTURAL WELDMENT, HLTS</b>	
DIMENSIONS ARE IN INCHES [MM] TOLERANCES: .XX ± .01 .XXX ± .005 ANGULAR ± 0.5°		MATERIAL: 304 OR 304L SSTL FINISH: N/A μinch		SYSTEM: ADVANCED LIGO SUB-SYSTEM: SUS NEXT ASSY: STRUCTURE, HLTS	
DESIGNER: D. BRIDGES DRAFTER: D. BRIDGES CHECKER: B. MOORE APPROVAL:		DATE: 29 MAY 2012 DATE: 29 MAY 2012 DATE: 29 MAY 2012		SIZE: E DWG. NO.: D070442 SCALE: 1:2 PROJECTION:	
				REV. v7 SHEET 1 OF 8	

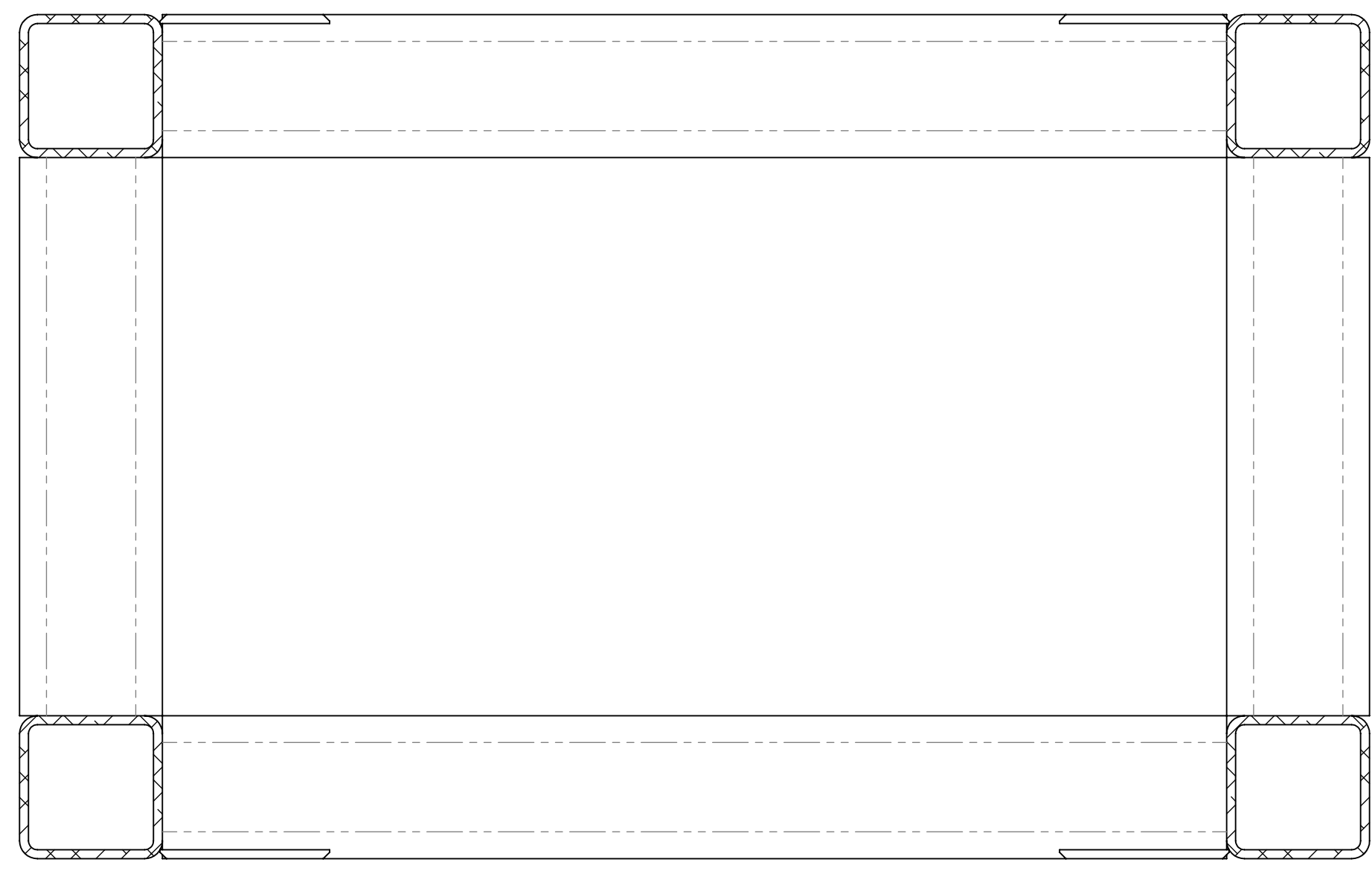

SECTION A-A

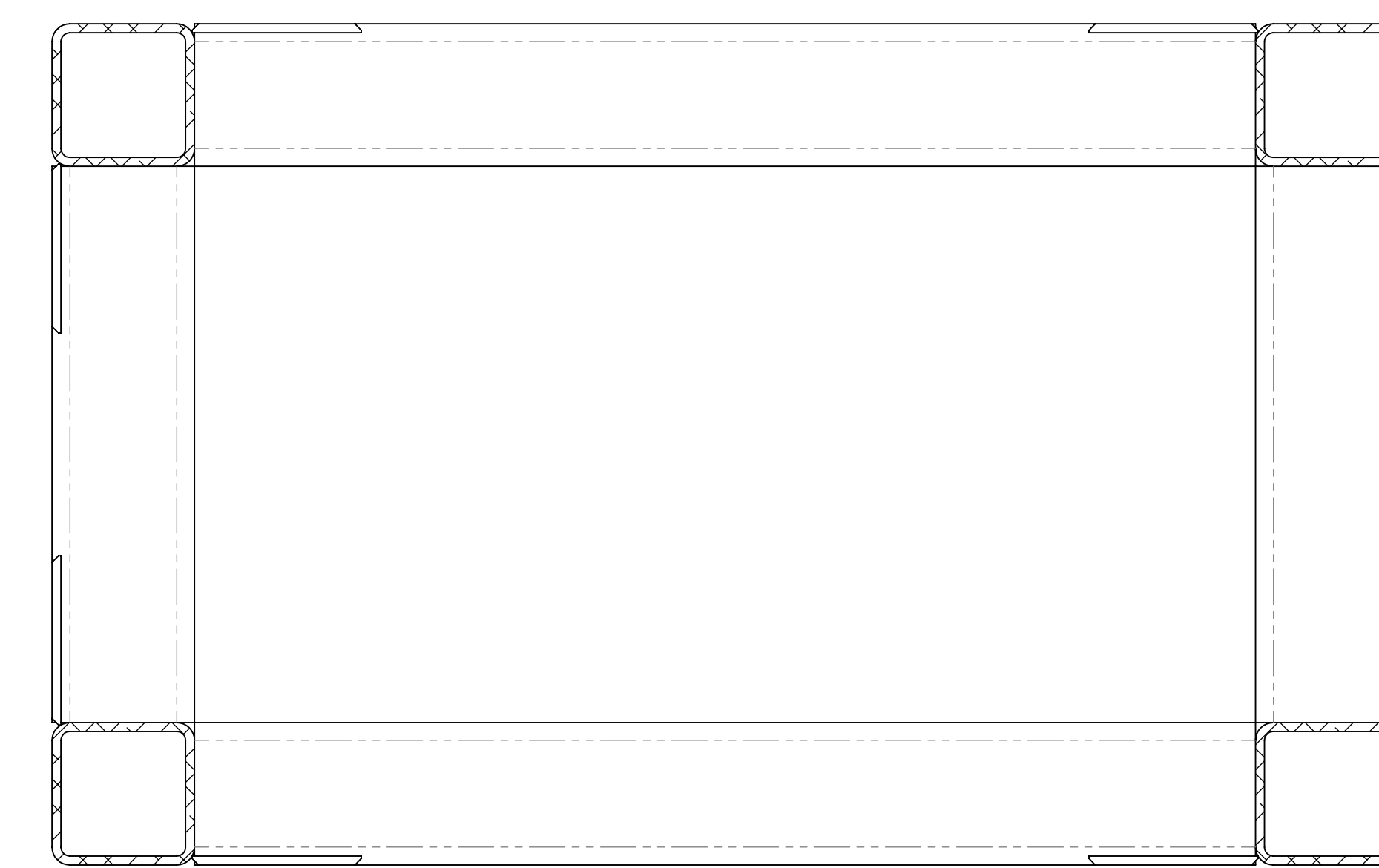

SECTION D-D

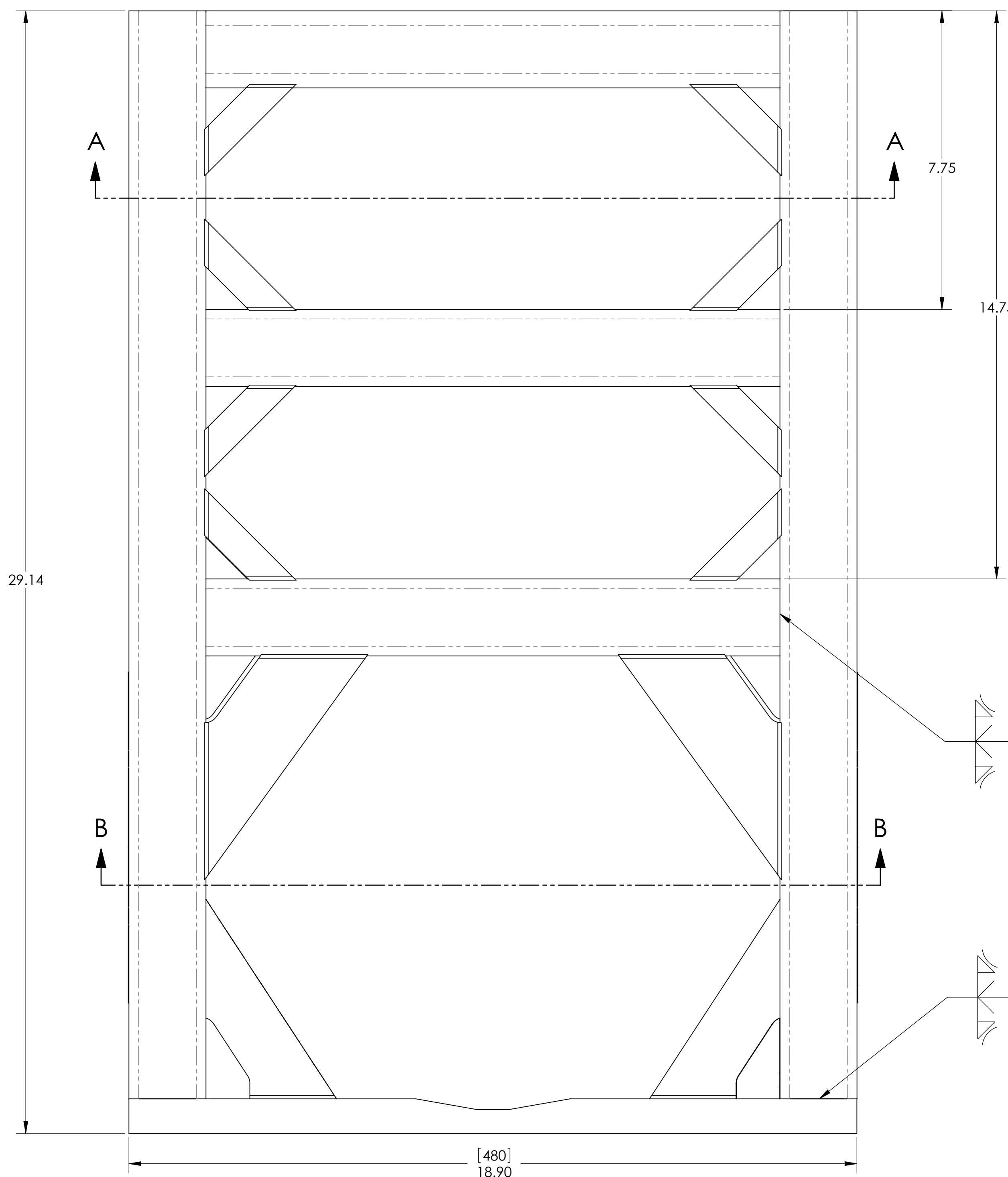

FULL LENGTH BOTH SIDES ALL PLACES

FULL LENGTH BOTH SIDES ALL PLACES

FULL LENGTH BOTH SIDES ALL PLACES

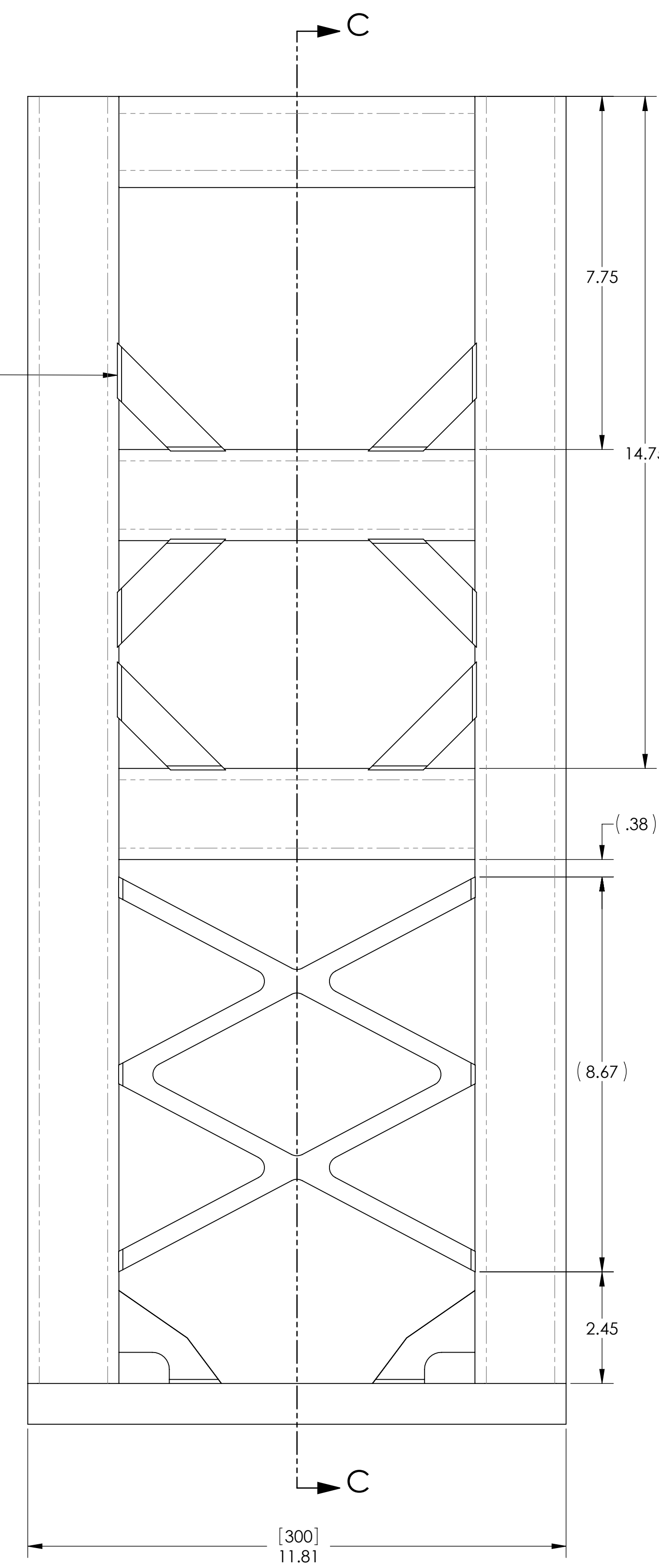

WELDMENT LAYOUT

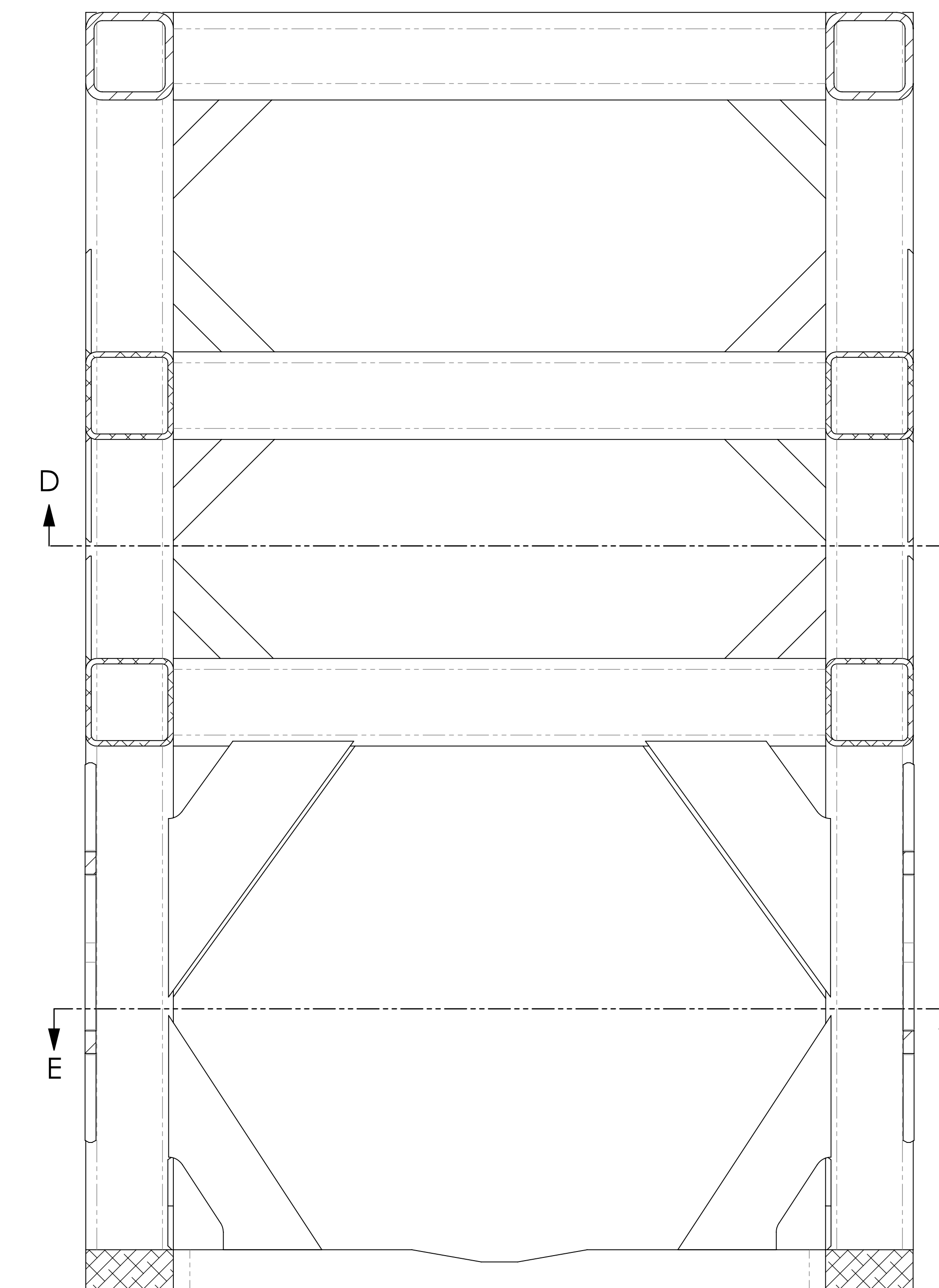

SECTION C-C

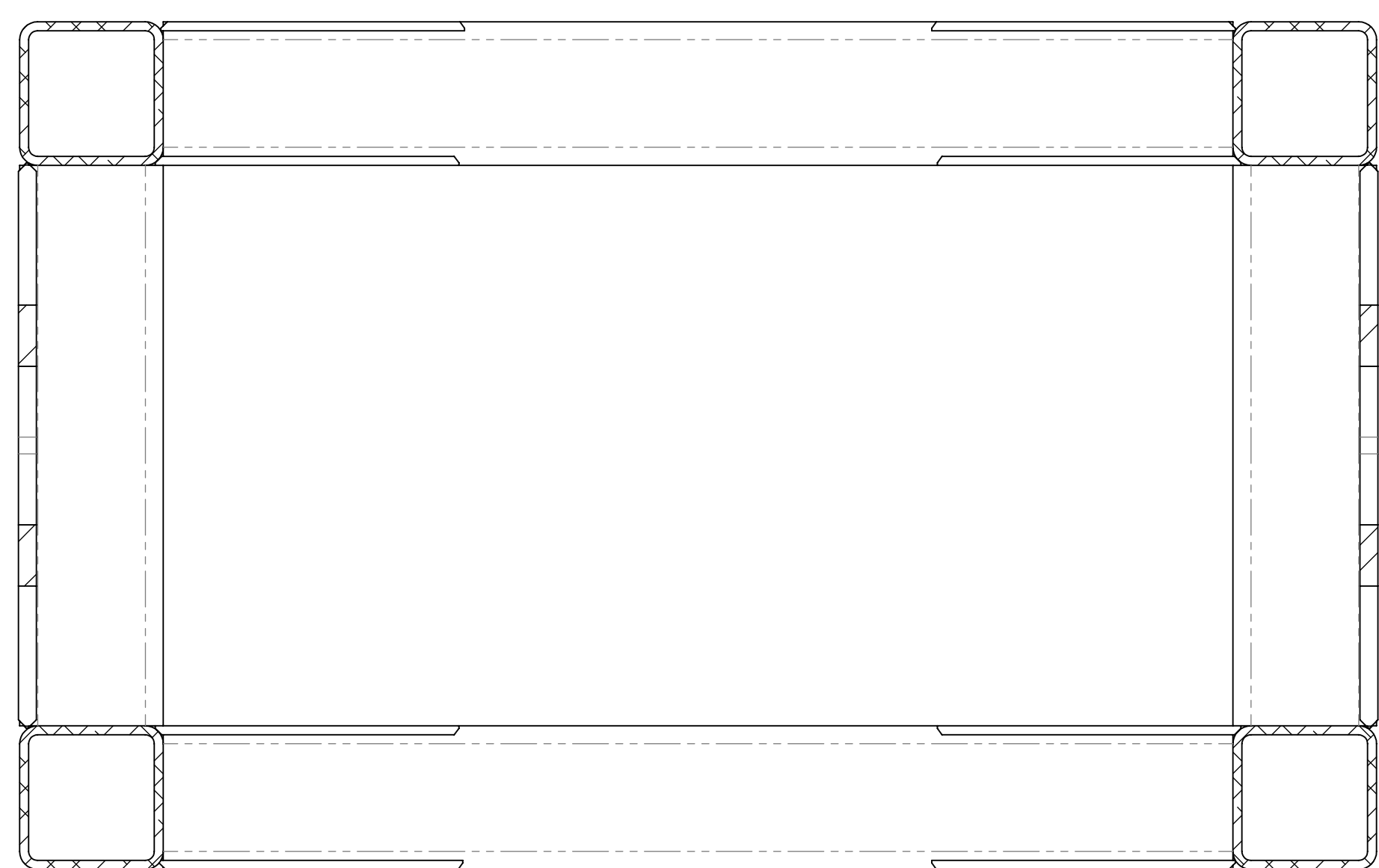

SECTION B-B

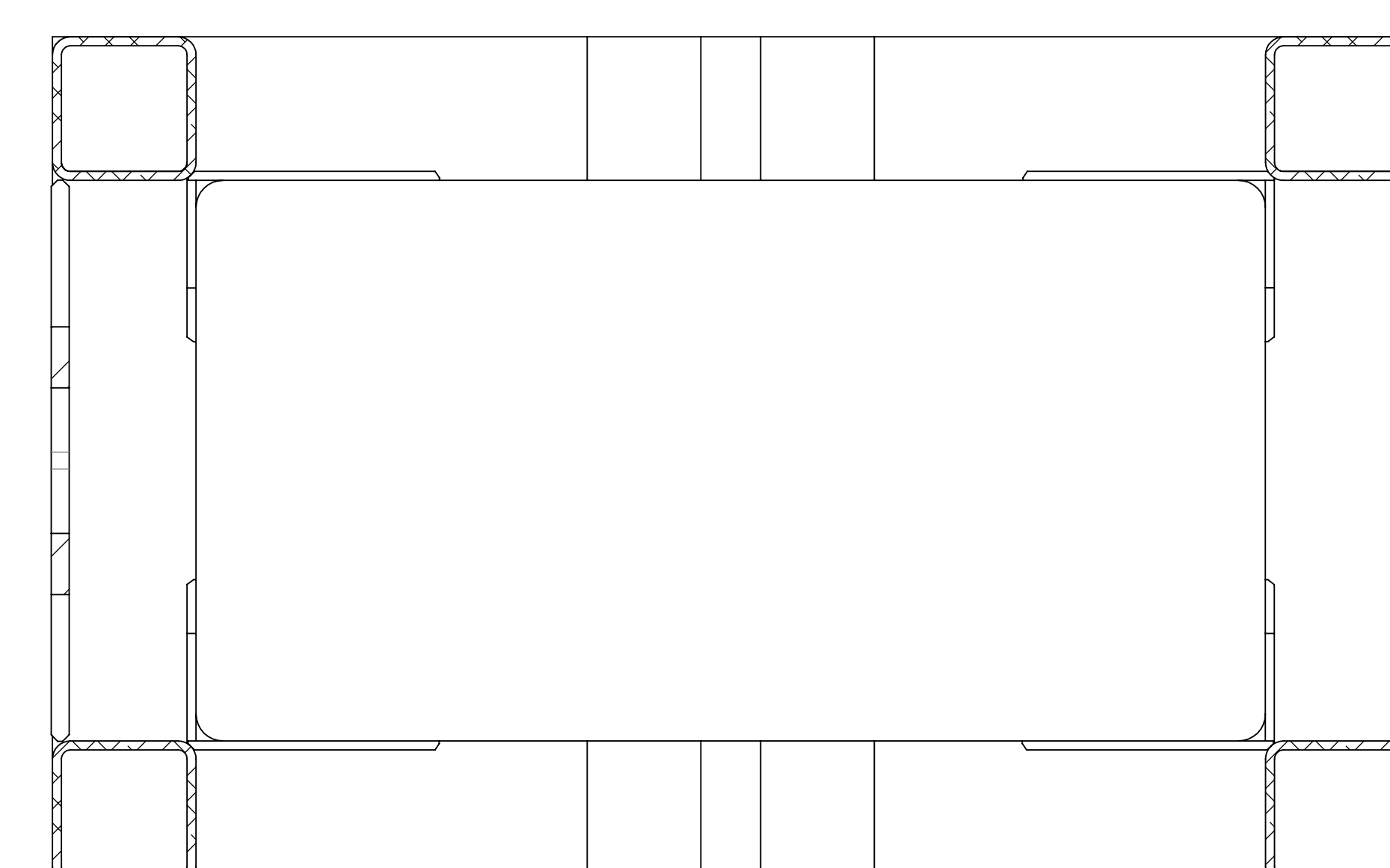

SECTION E-E

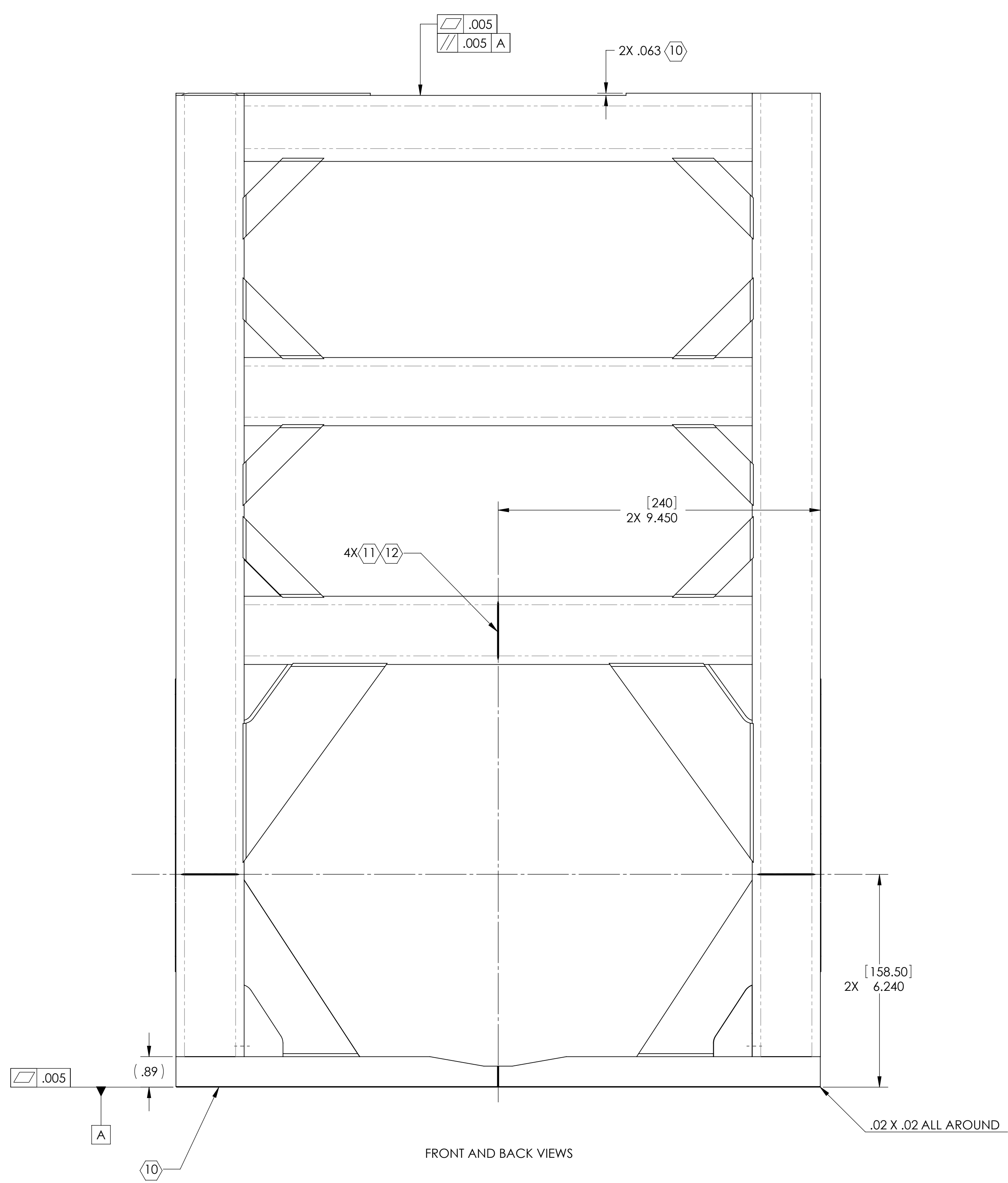
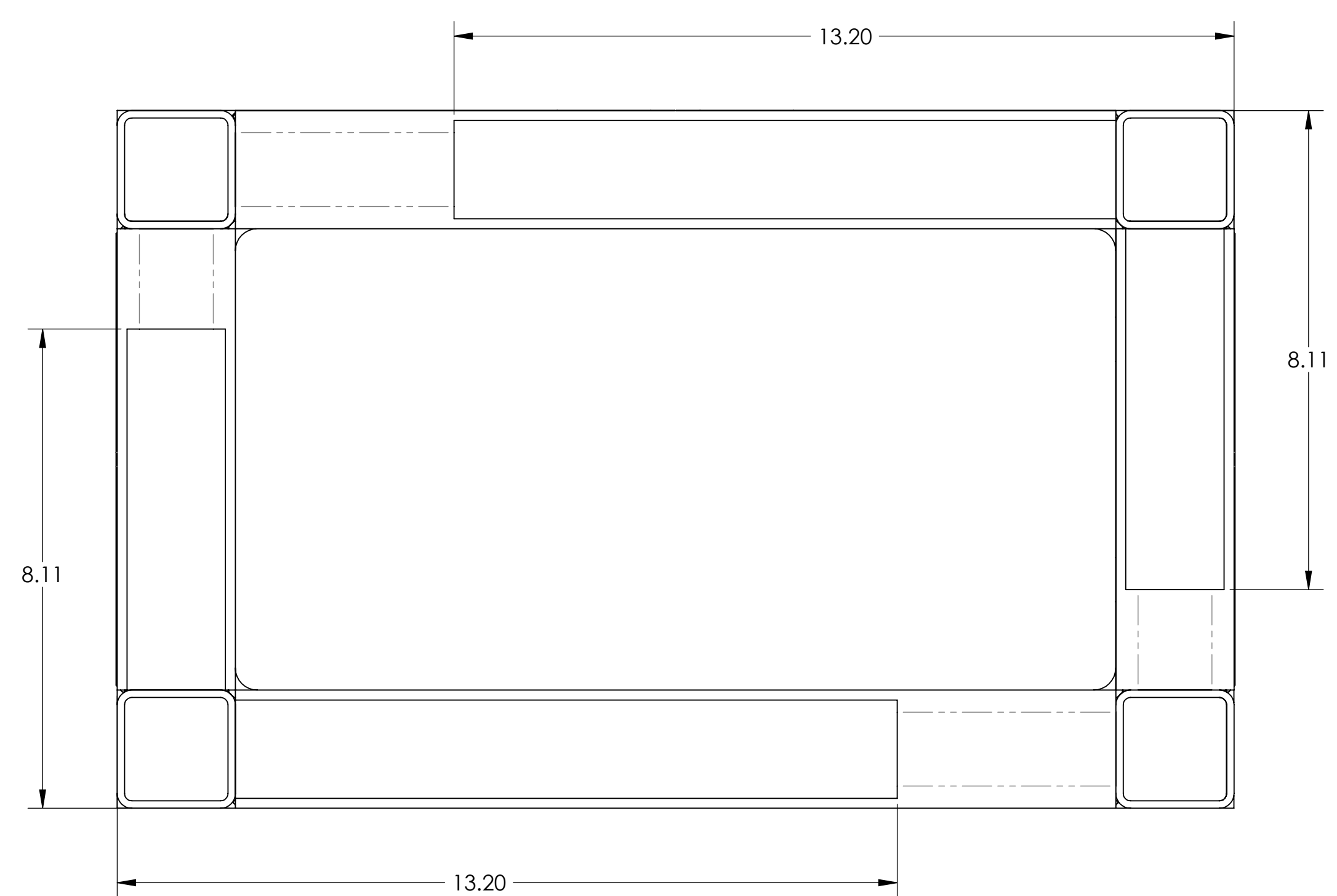

FRONT AND BACK VIEWS

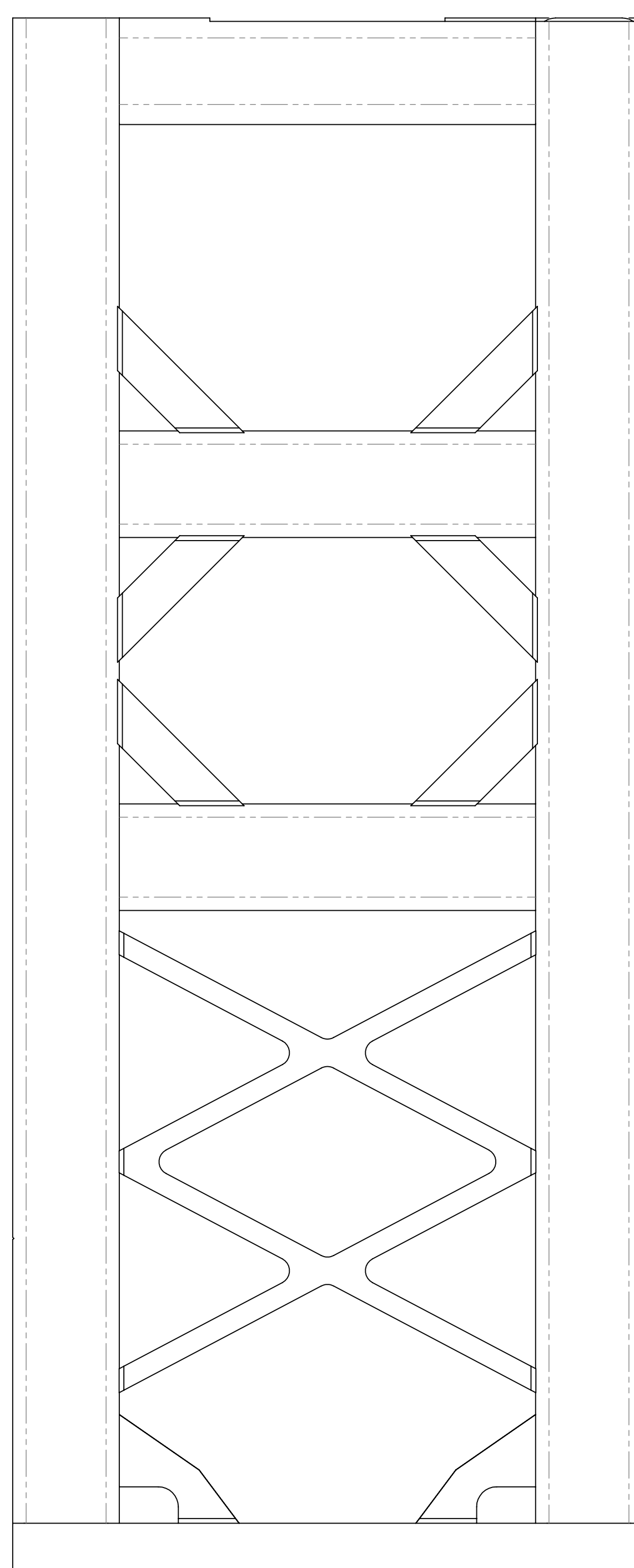

RIGHT AND LEFT VIEWS

MACHINING LAYOUT

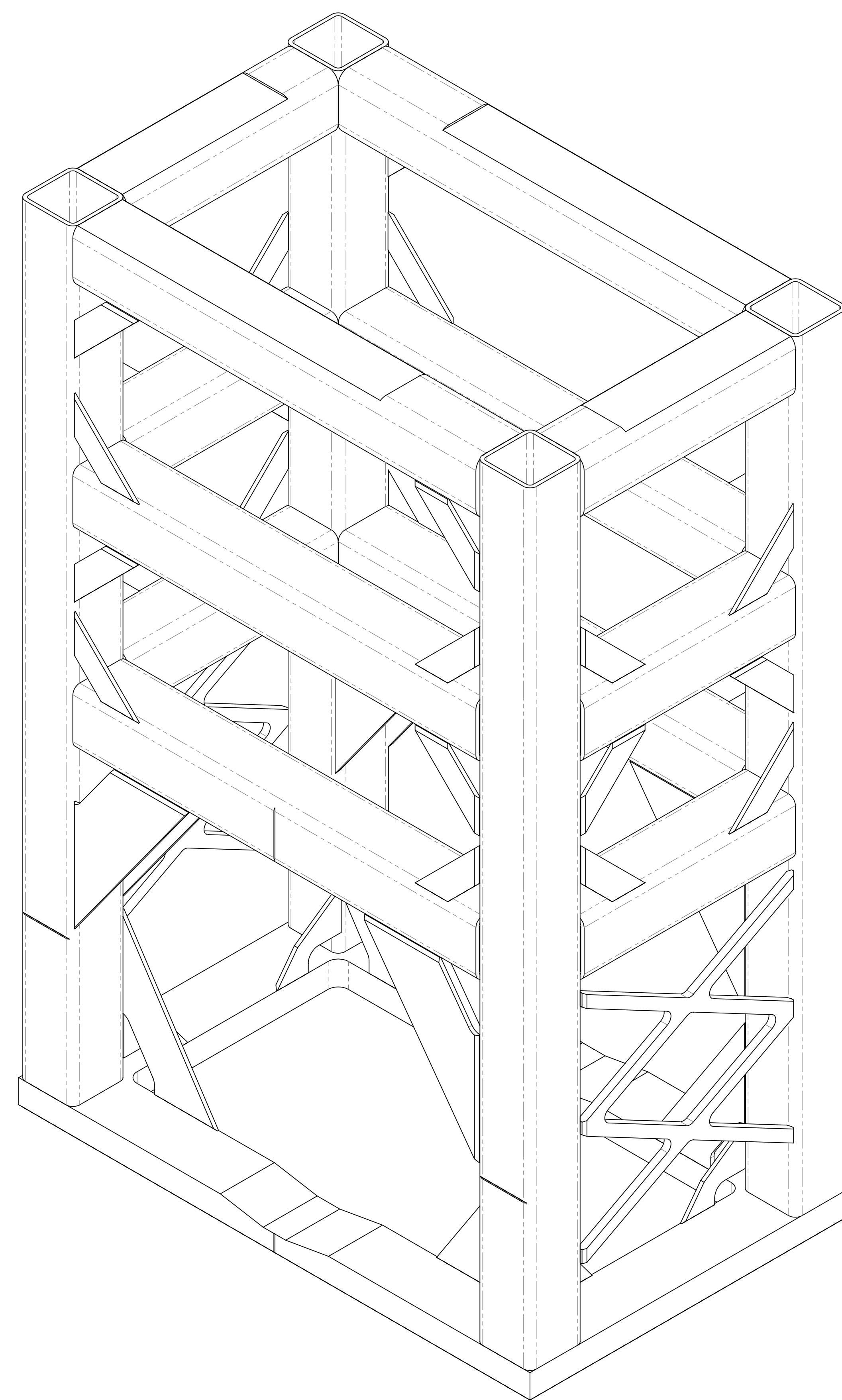

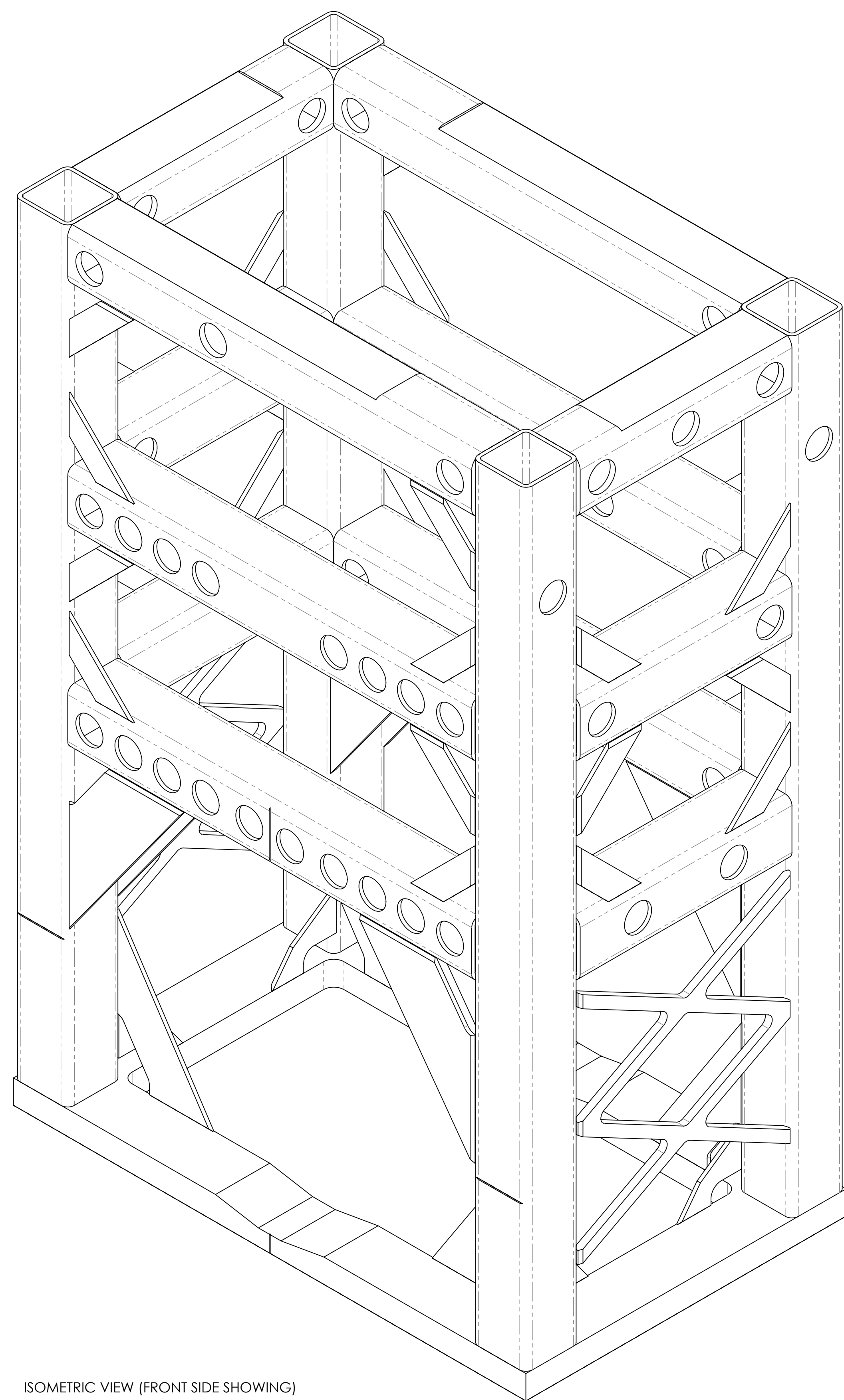

ISOMETRIC VIEW (FRONT SIDE SHOWING)

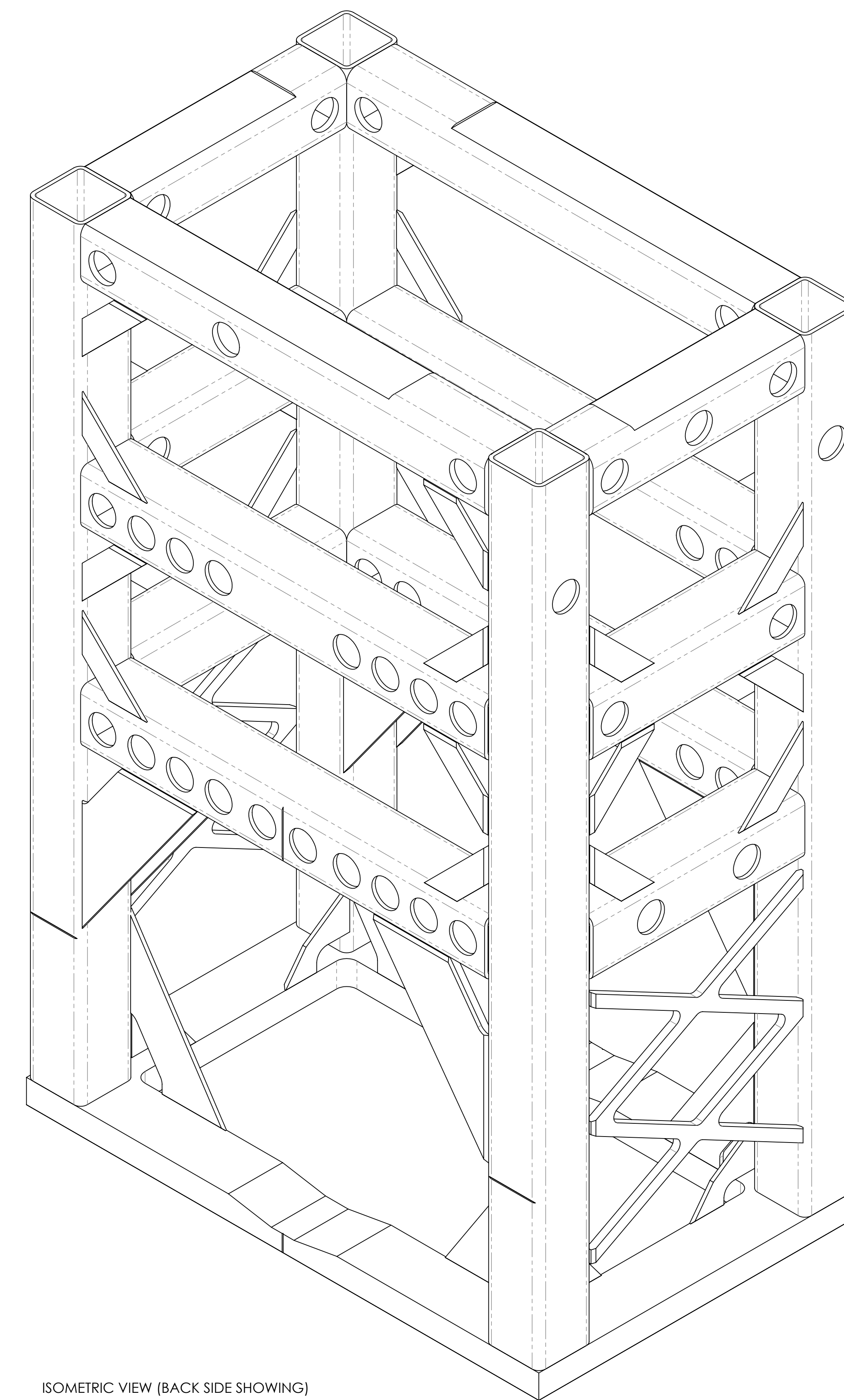

ISOMETRIC VIEW (BACK SIDE SHOWING)

ISOMETRIC VIEWS FOR LARGE HOLE PLACEMENT

D:\BAGZ\_Archived\_LIGO\_SUSEL\Archived\_WebContent\_PDF\DWGREV\_03\BAGZ\_PDF\REV\_14\001



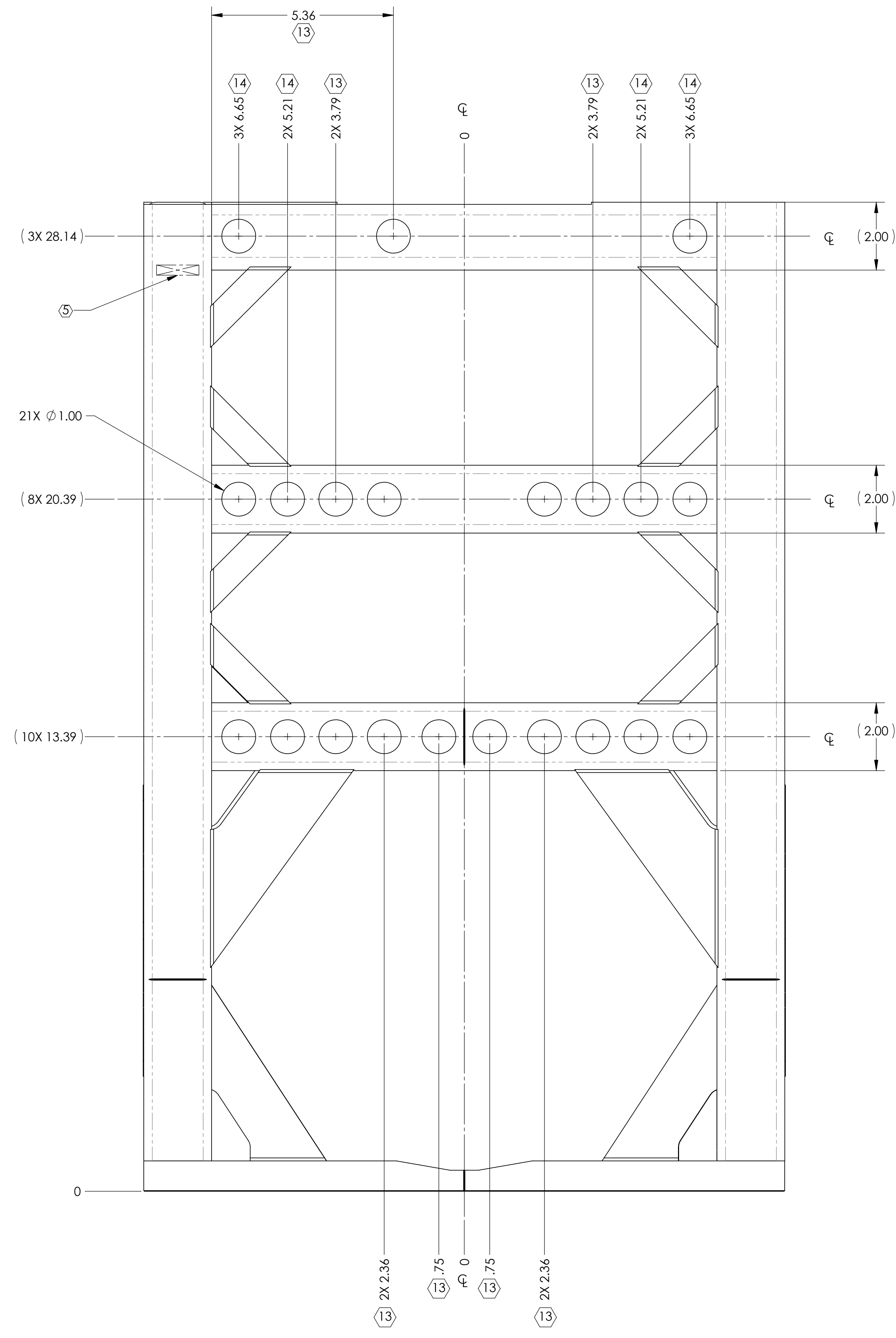

FRONT VIEW

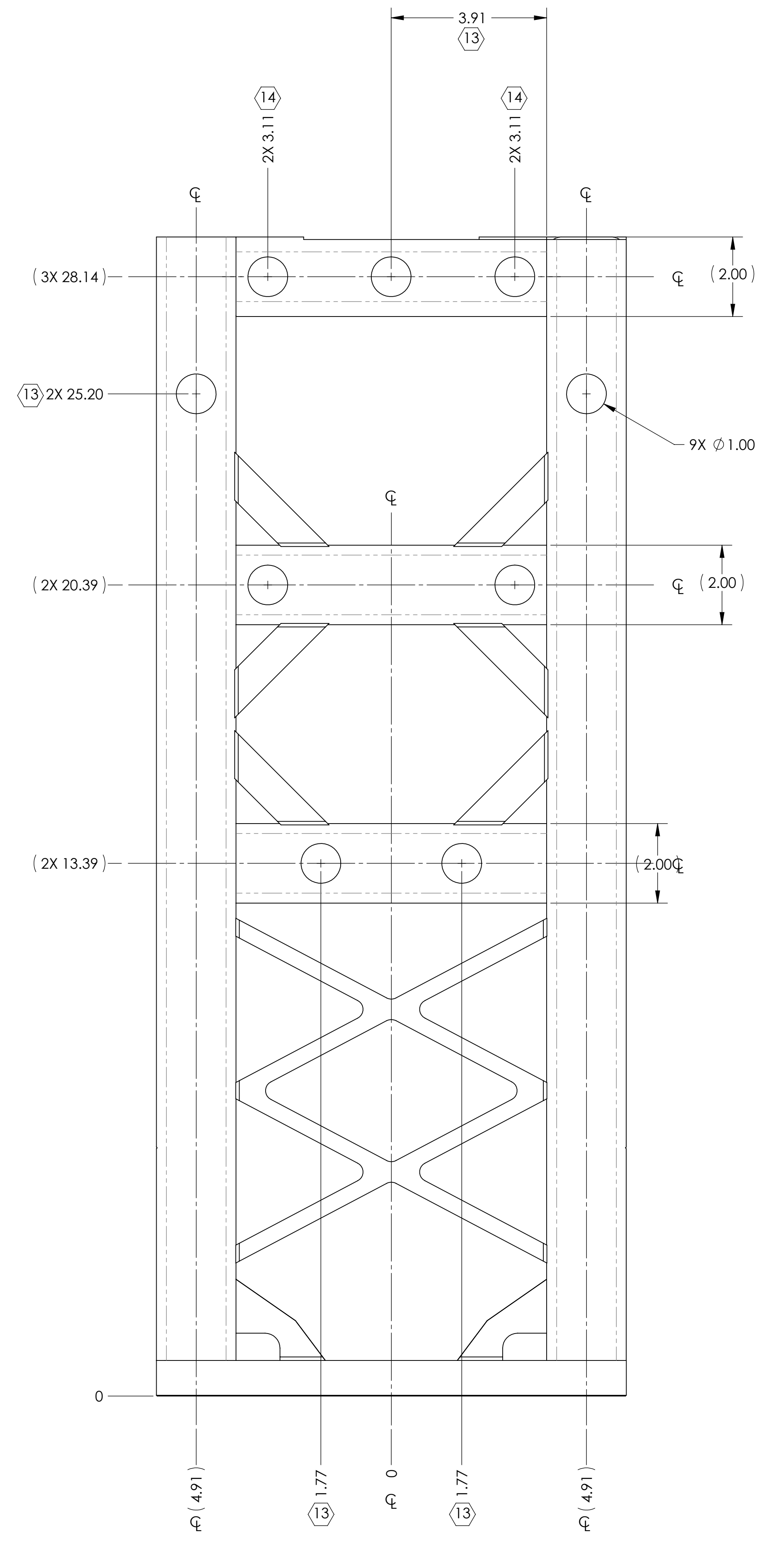

RIGHT AND LEFT VIEWS

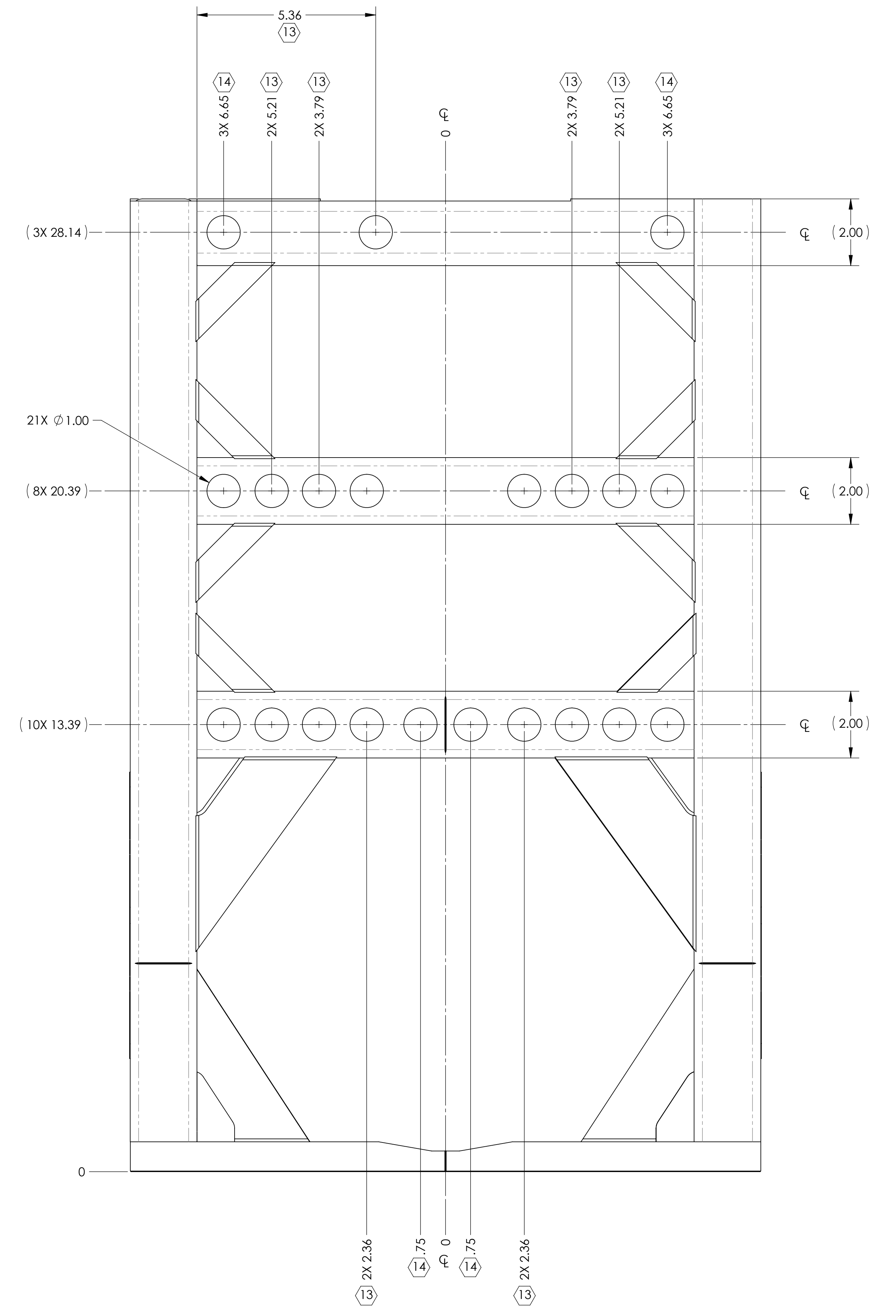

BACK VIEW

LARGE HOLE LAYOUT

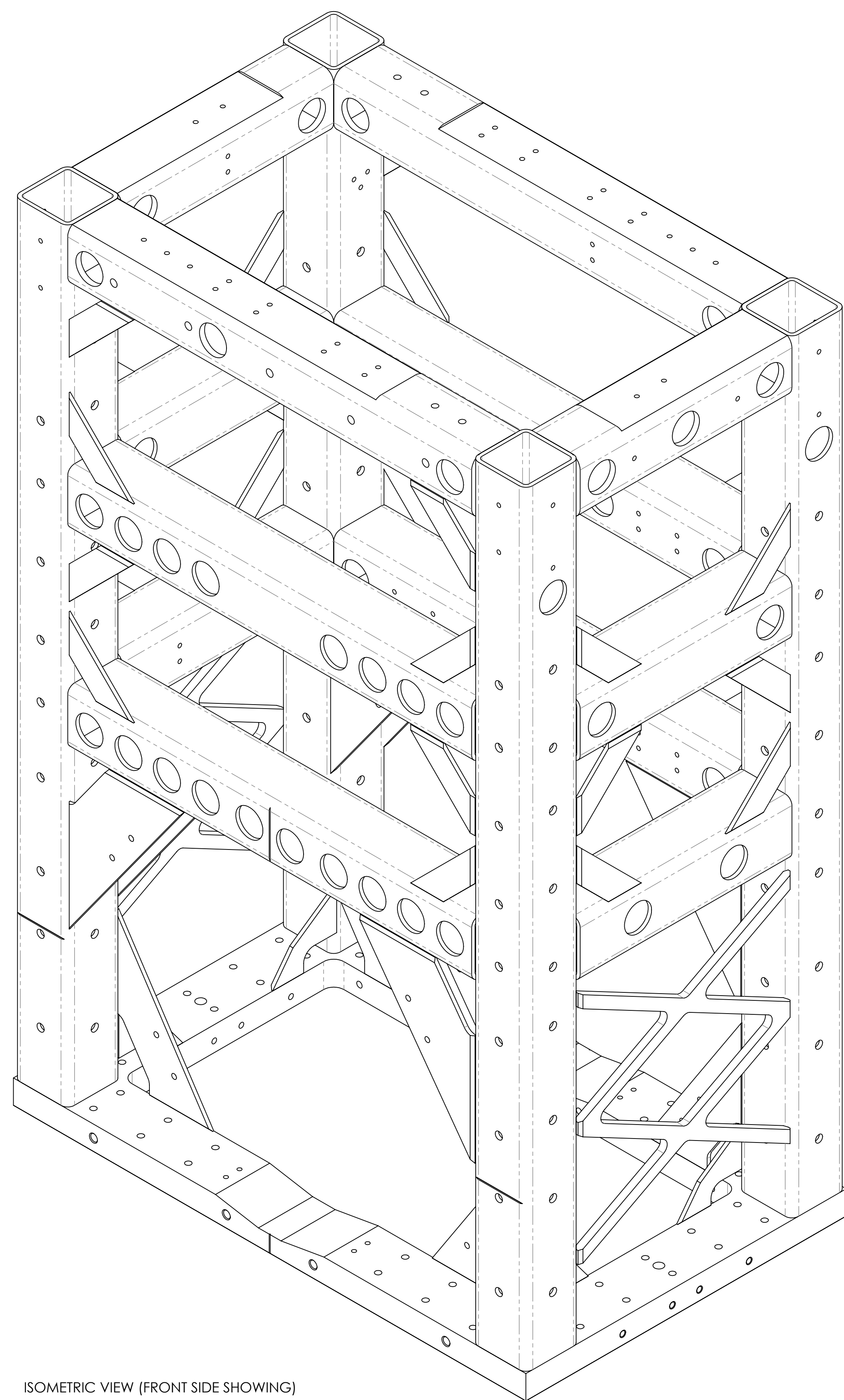

ISOMETRIC VIEW (FRONT SIDE SHOWING)

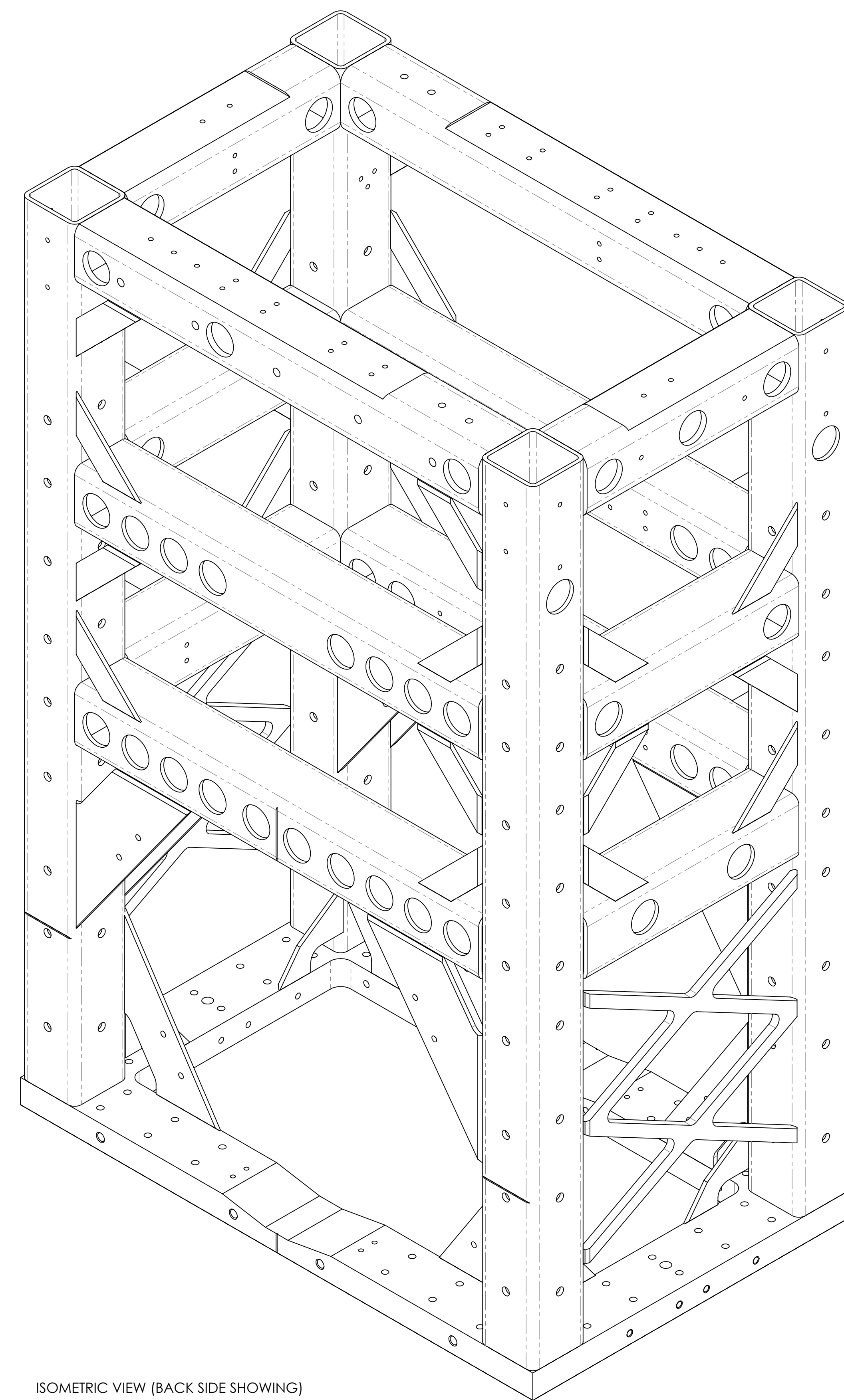

ISOMETRIC VIEW (BACK SIDE SHOWING)

ISOMETRIC VIEWS FOR LARGE HOLE PLACEMENT

D:\BAGZ\_Armed\JCC\JCC\_LITE\Booked\WorkItem\PART\DWG\REV. 03\BAGZ\_P01\REV. 14.001

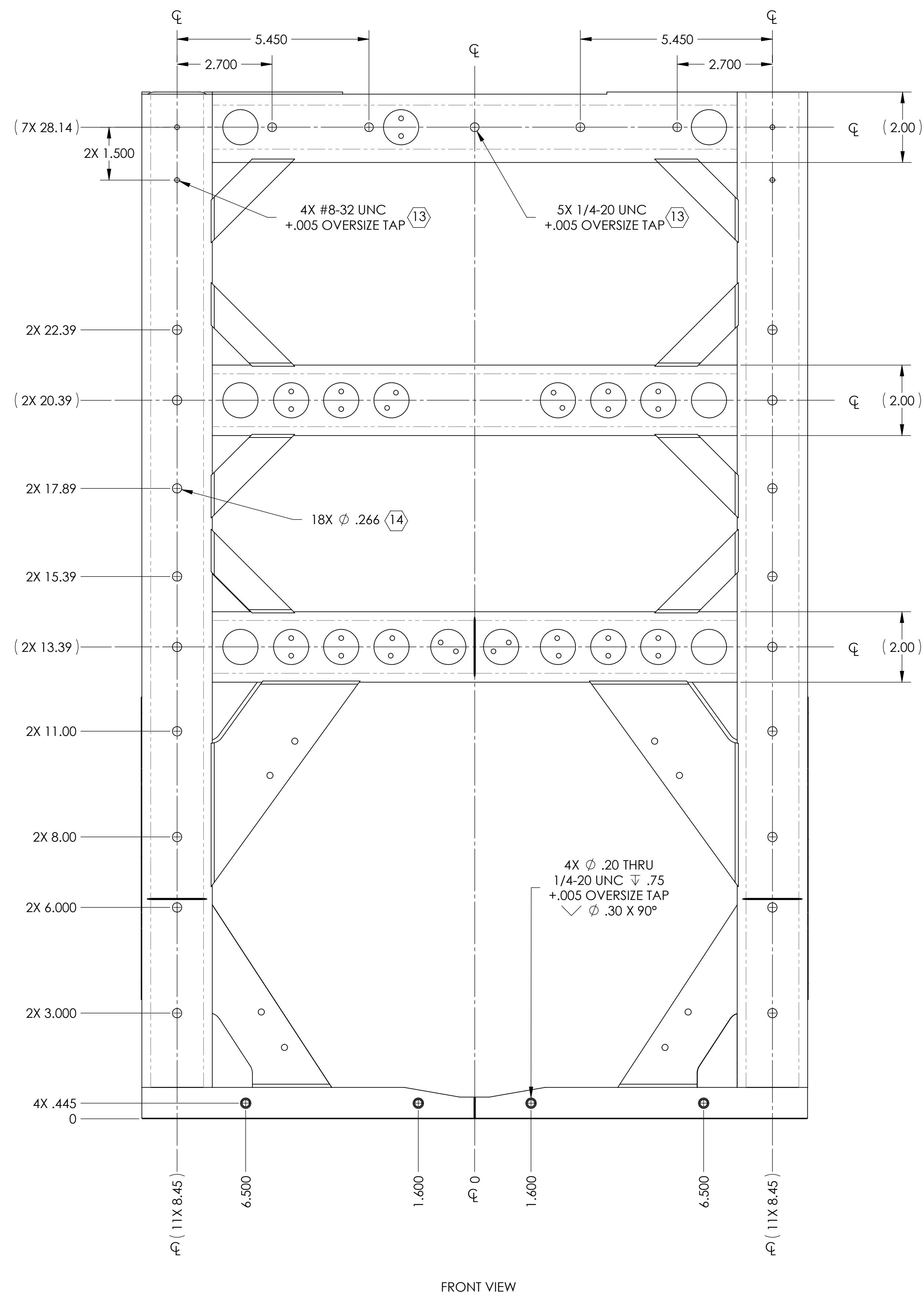
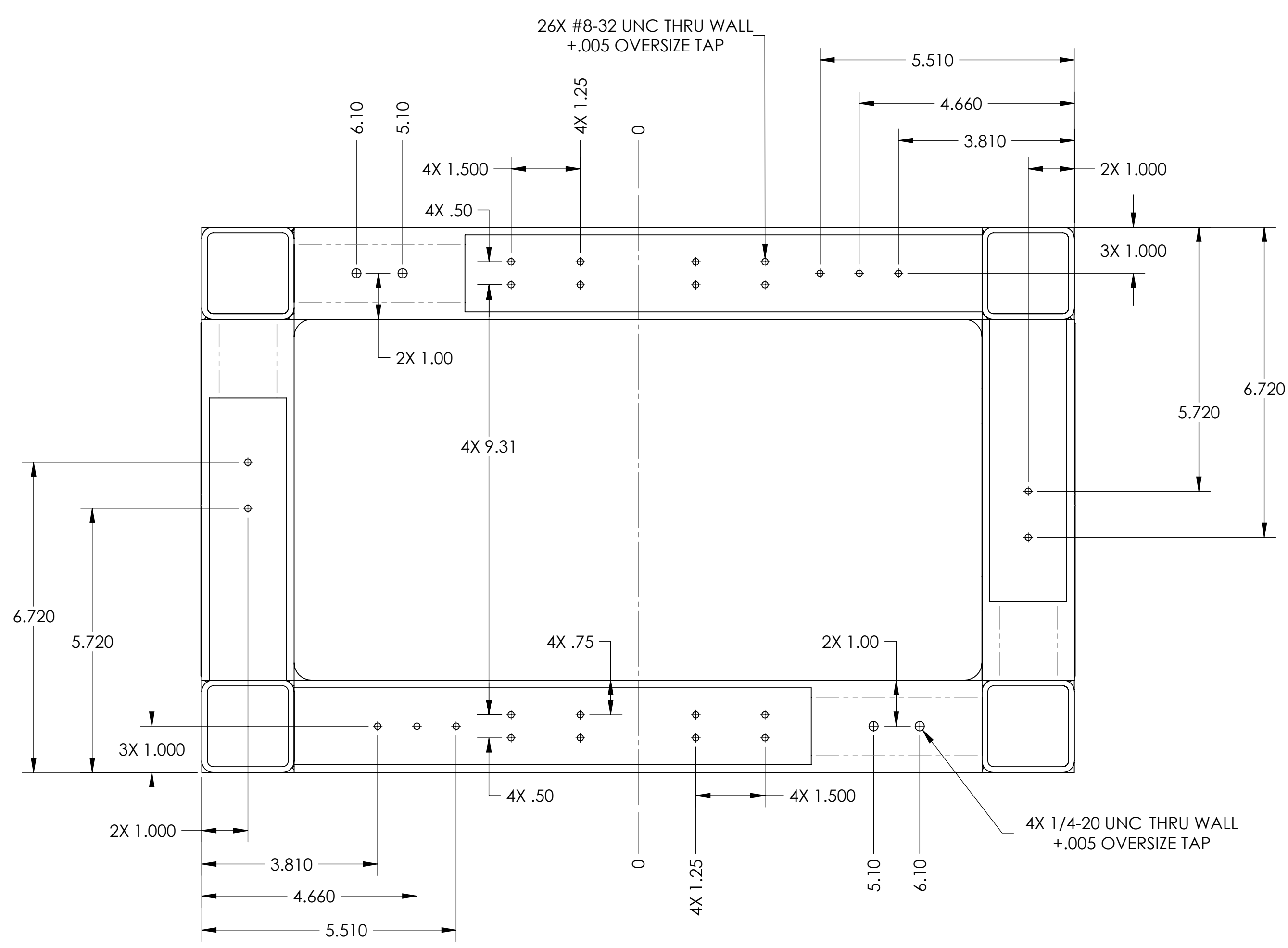

FRONT VIEW

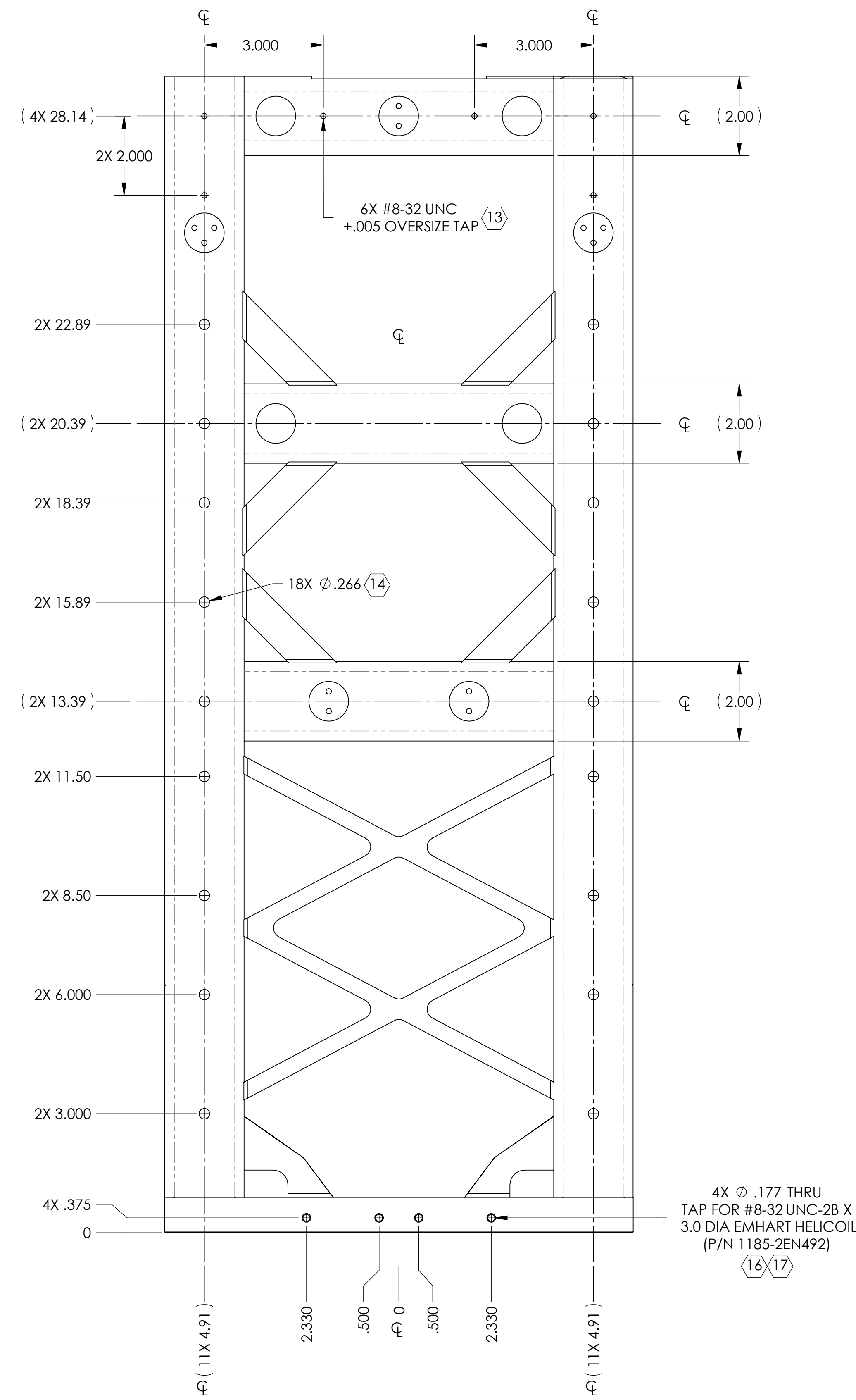

RIGHT AND LEFT VIEWS

SMALL HOLE LAYOUT

4X Ø .177 THRU  
TAP FOR #8-32 UNC-28 X  
3.0 DIA EMHART HELICOIL  
(P/N 1185-2EN492)  
(16/17)

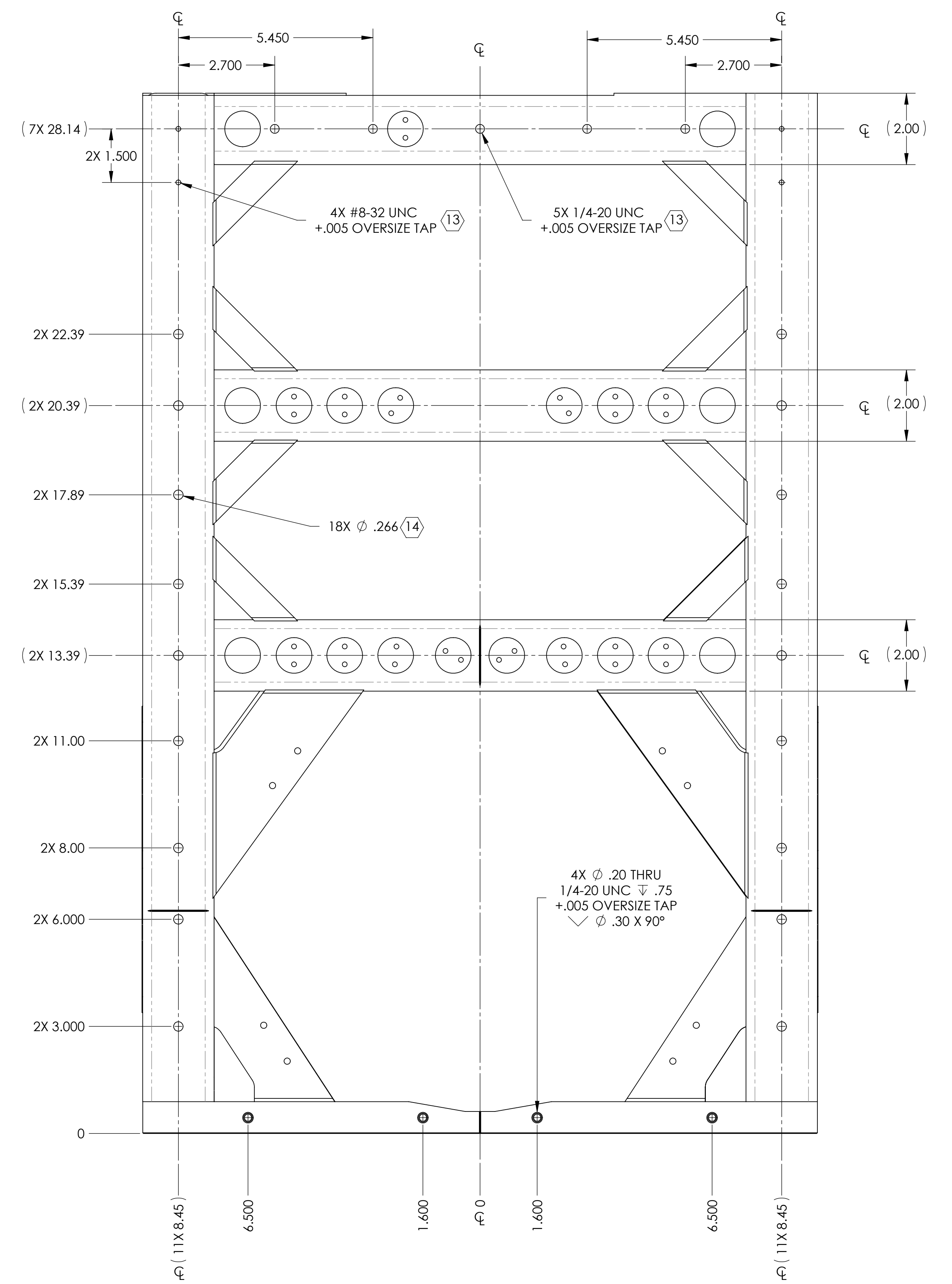

BACK VIEW

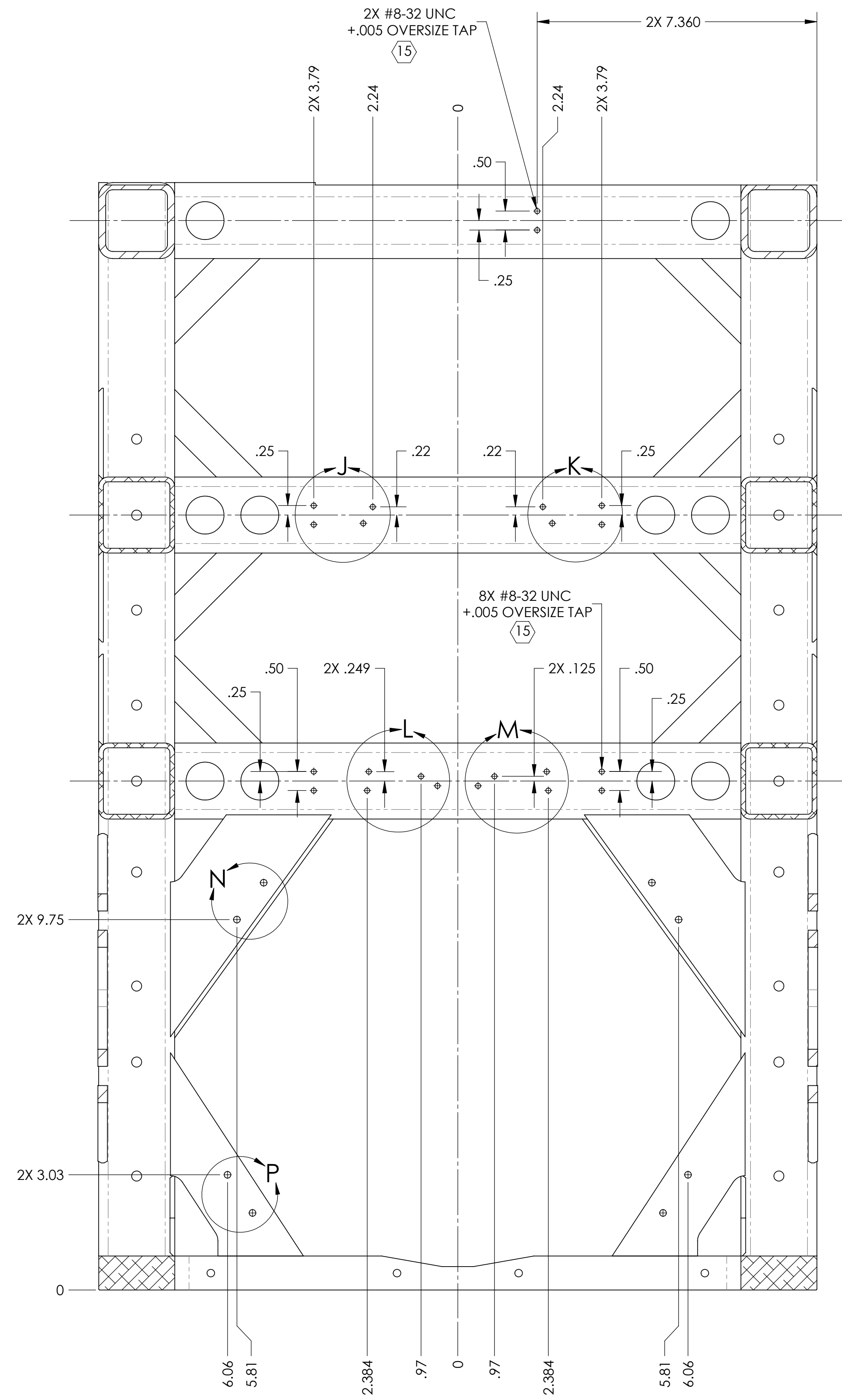

SECTION F-F  
FRONT INSIDE VIEW

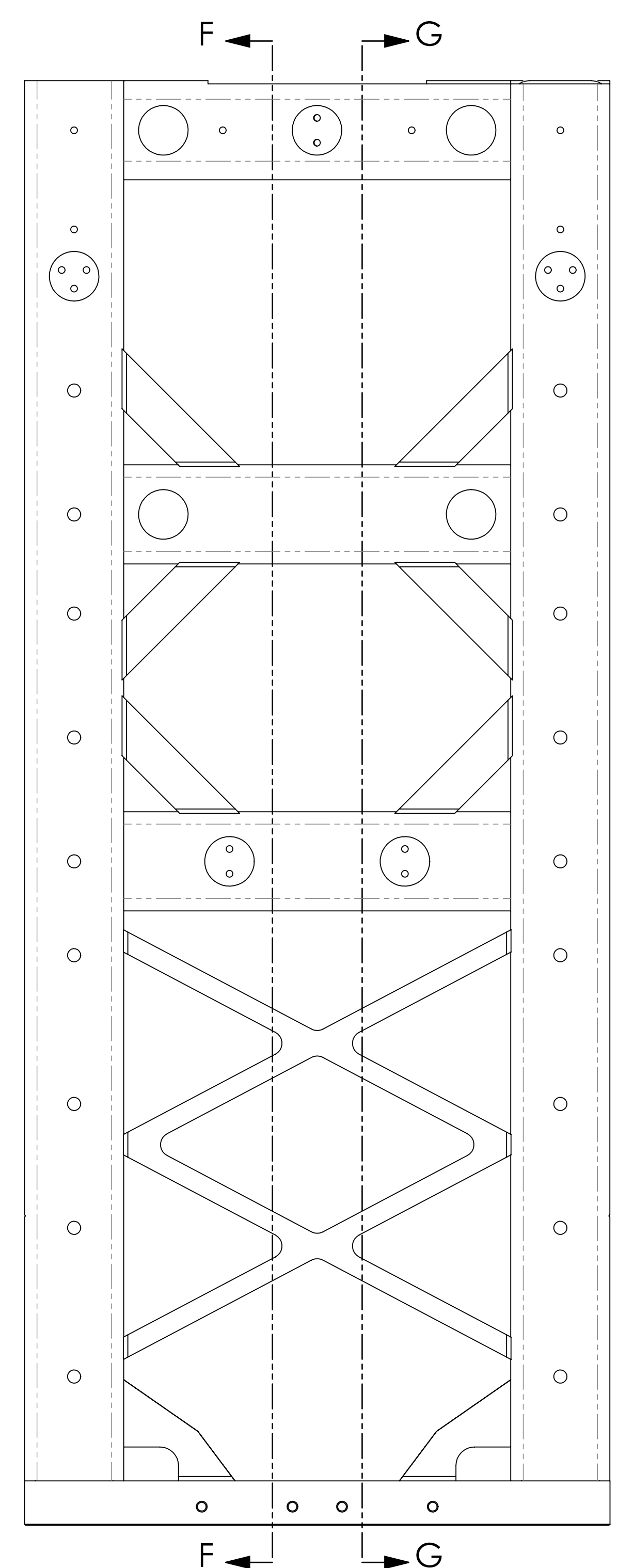

LEFT AND RIGHT VIEWS

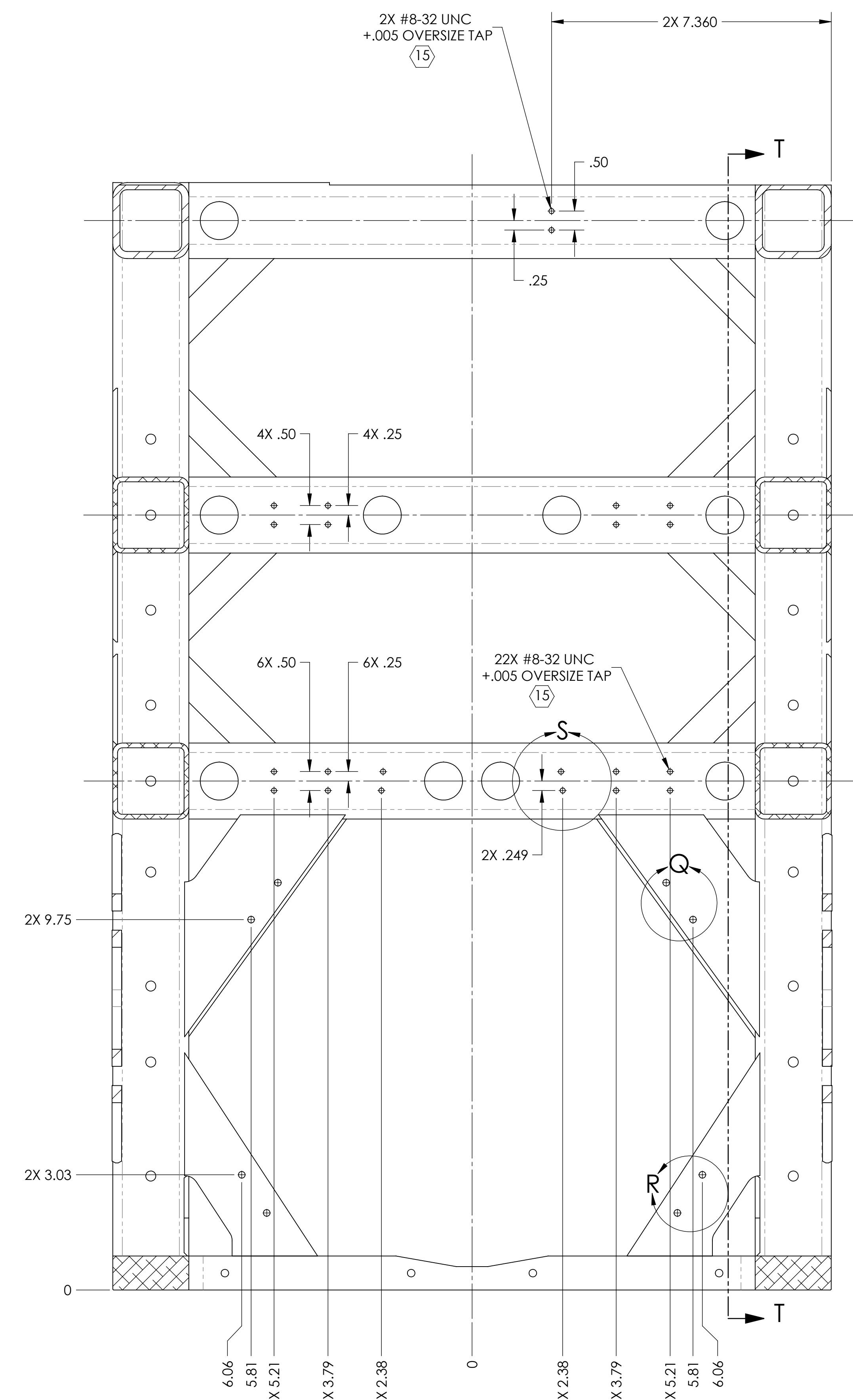

SECTION G-G  
BACK INSIDE VIEW

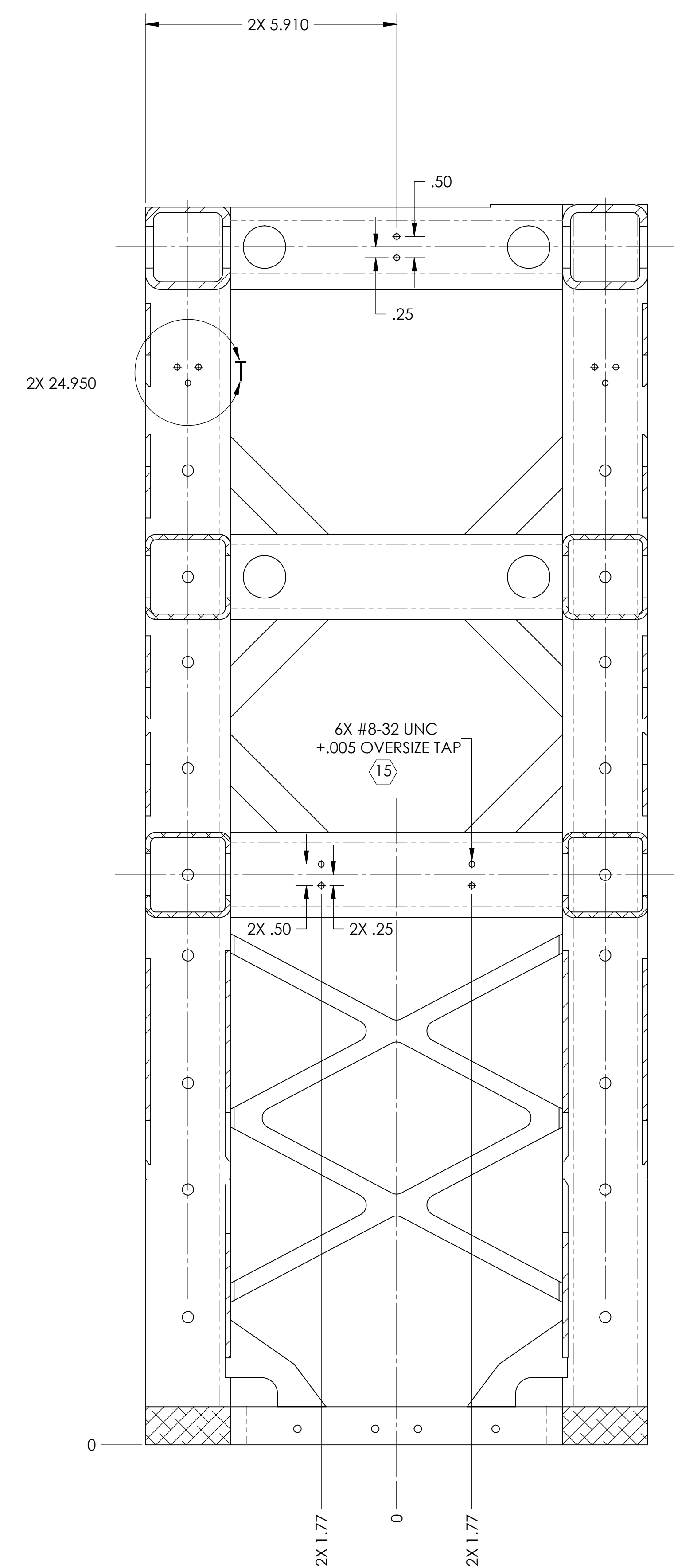

SECTION T-T  
LEFT AND RIGHT INSIDE VIEWS

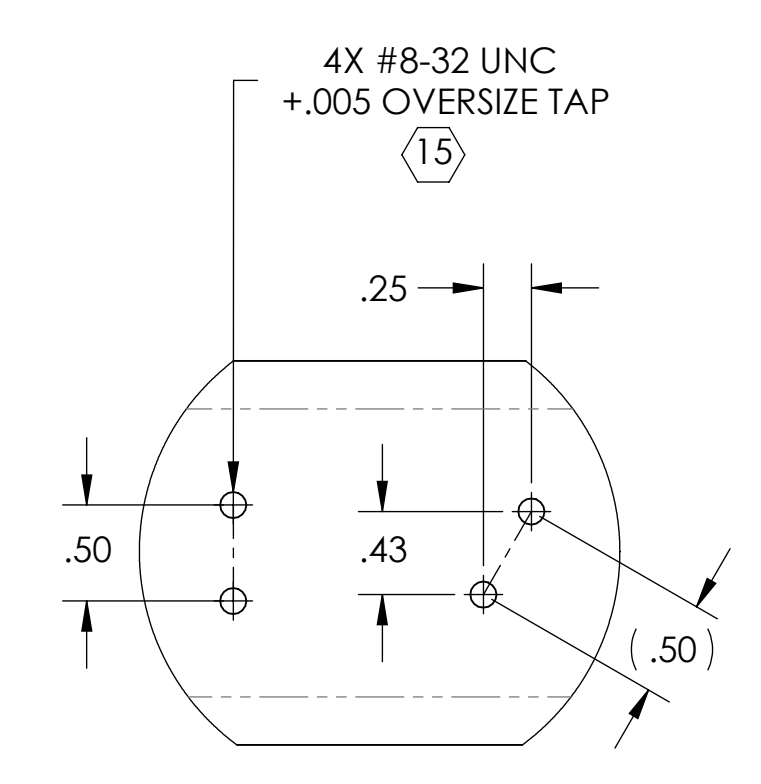
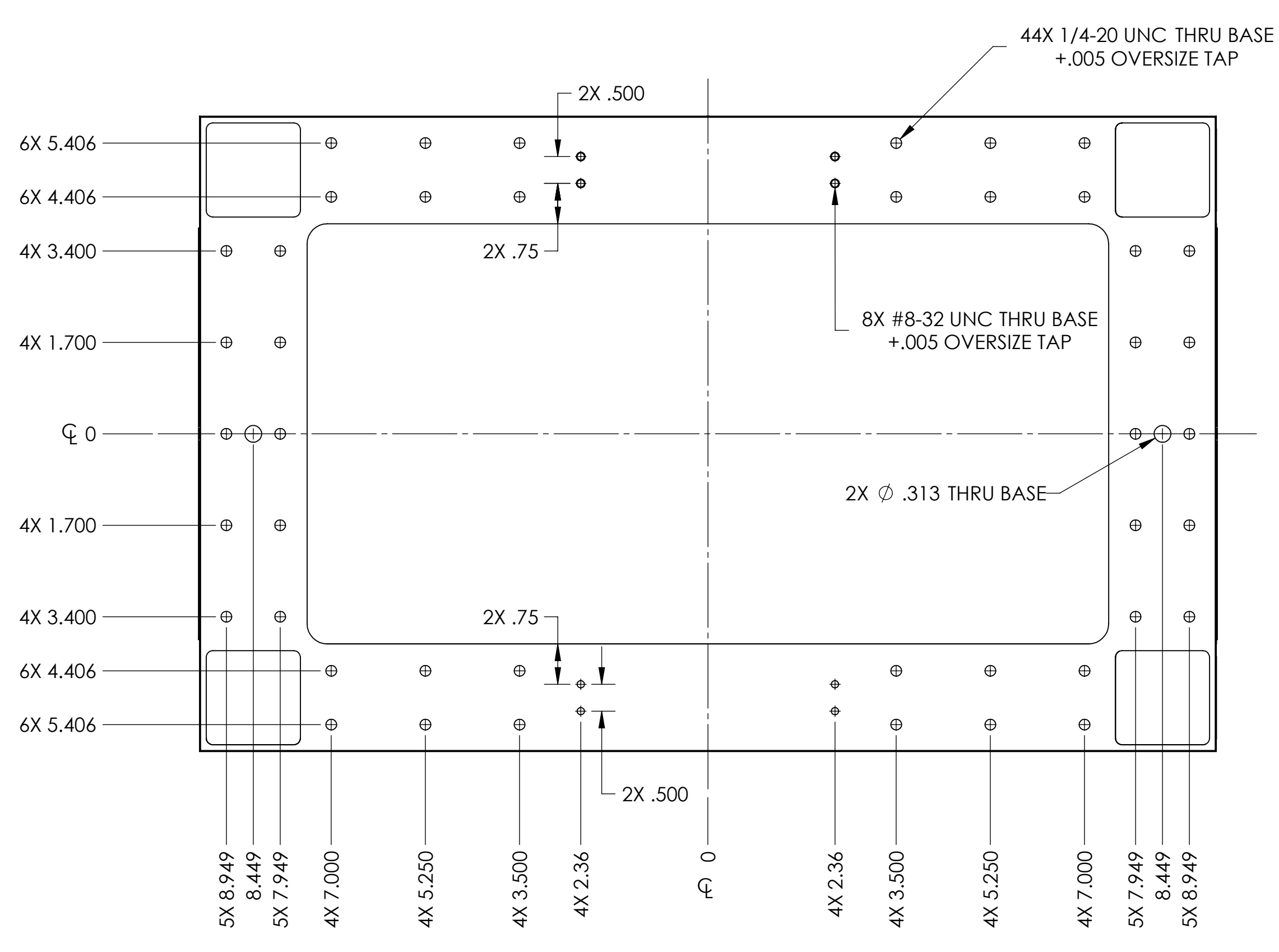

DETAIL J  
SCALE 1 : 1

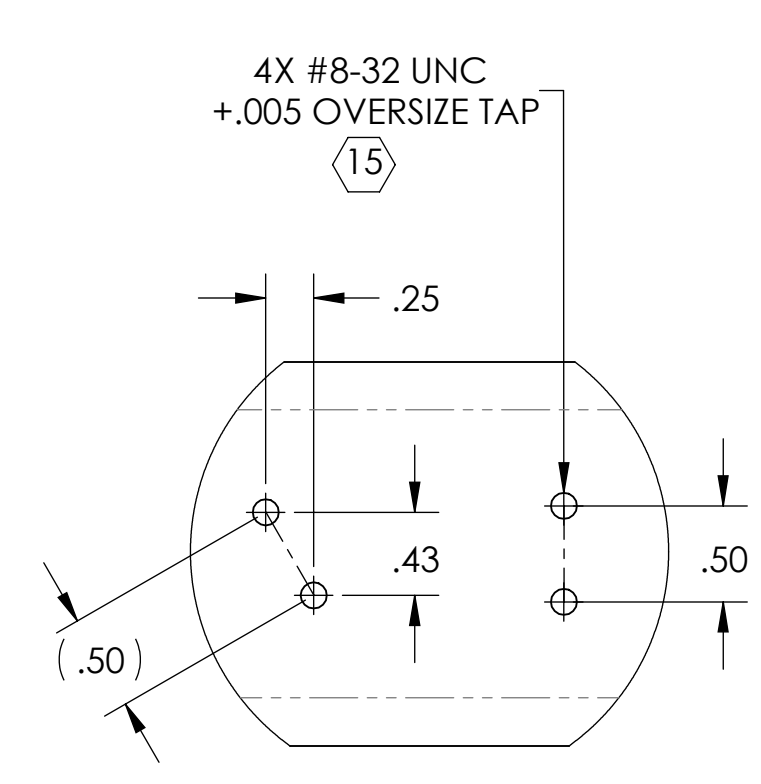

DETAIL K  
SCALE 1 : 1

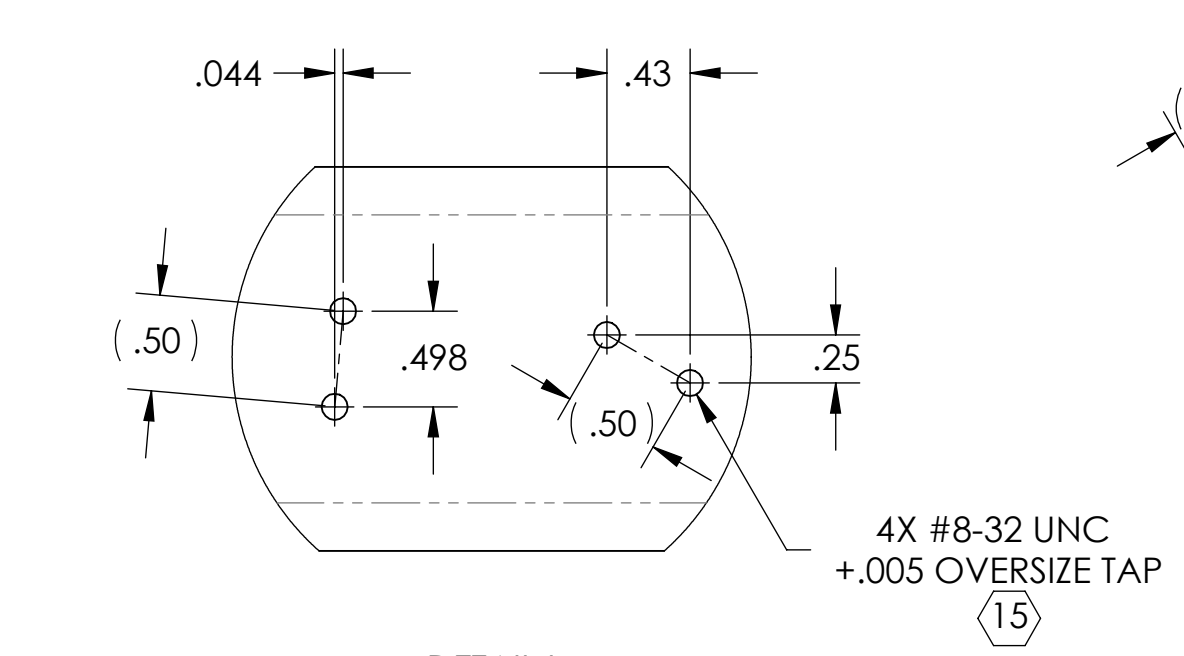

DETAIL L  
SCALE 1 : 1

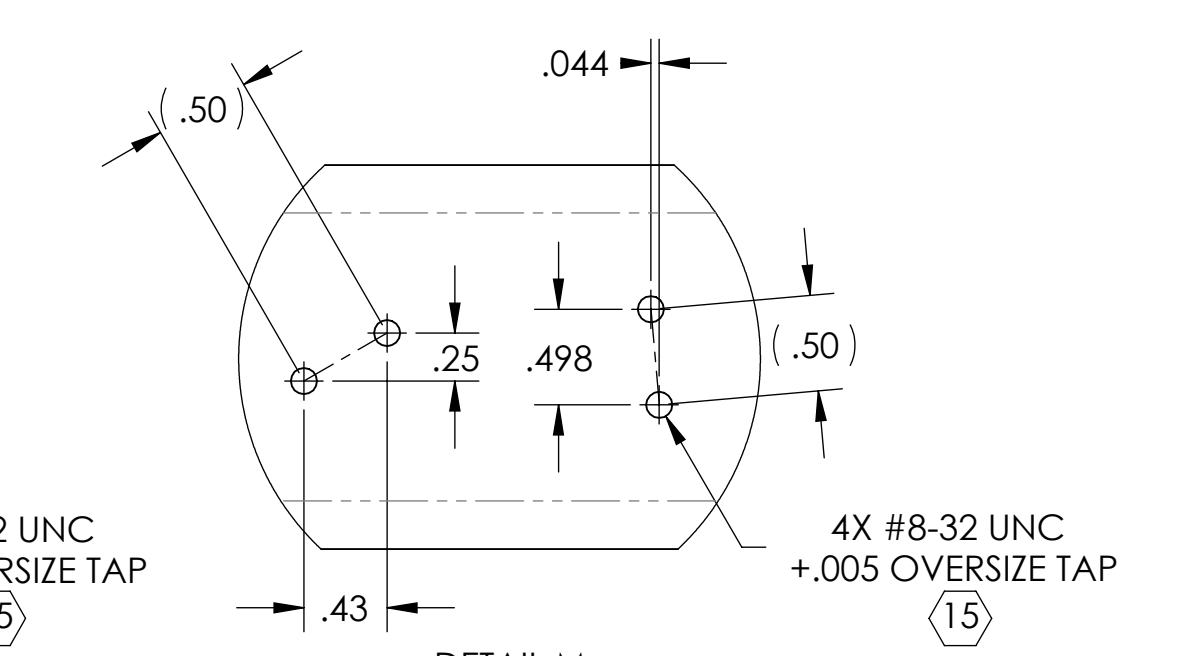

DETAIL M  
SCALE 1 : 1

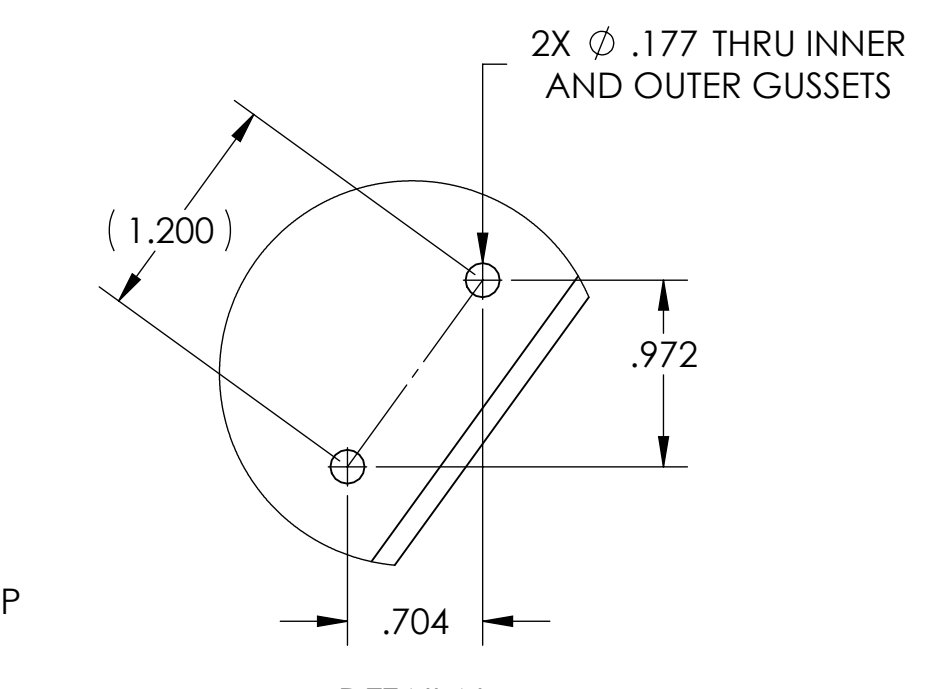

DETAIL N  
SCALE 1 : 1  
2 PLACES

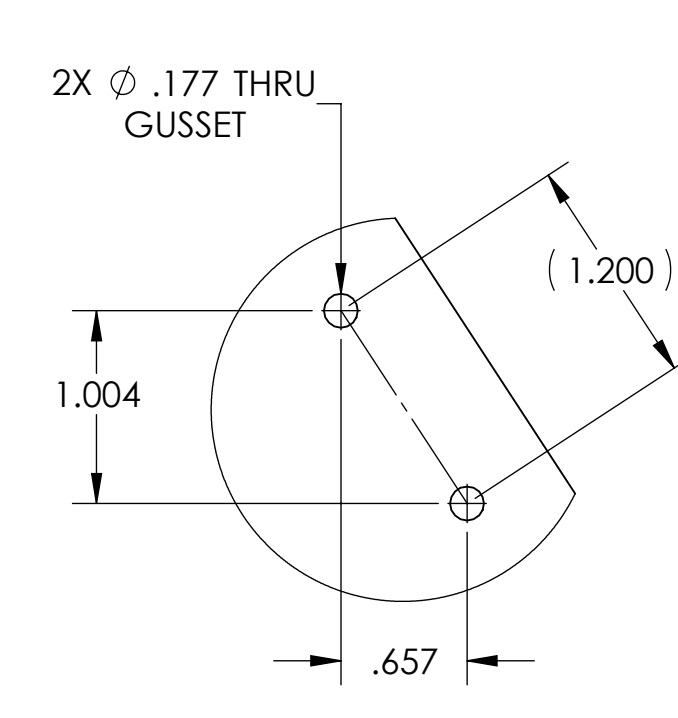

DETAIL P  
SCALE 1 : 1  
2 PLACES

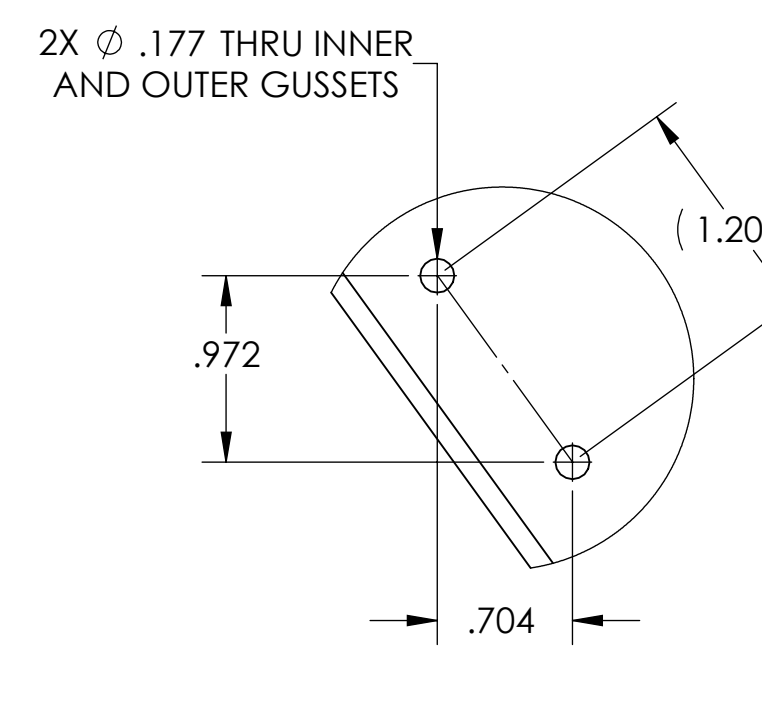

DETAIL Q  
SCALE 1 : 1  
2 PLACES

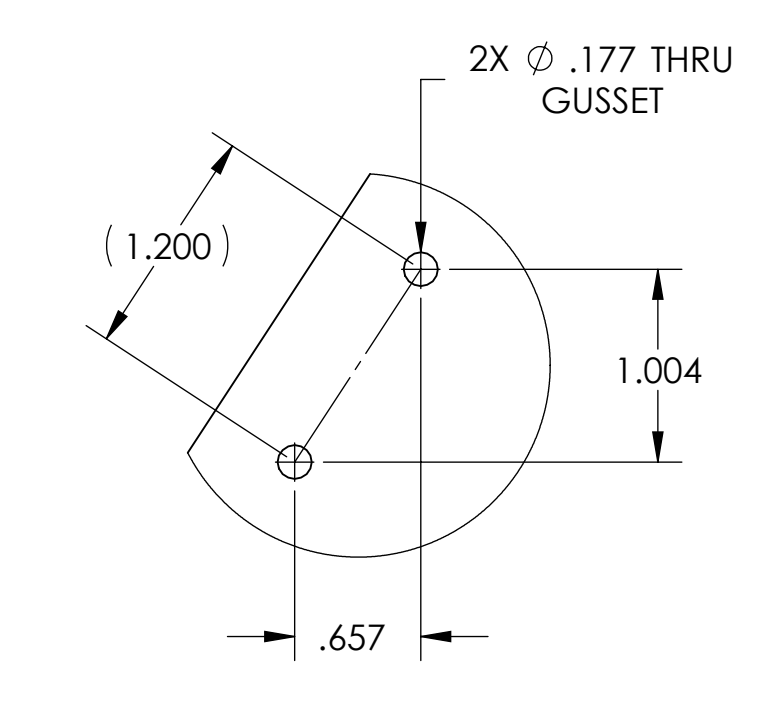

DETAIL R  
SCALE 1 : 1  
2 PLACES

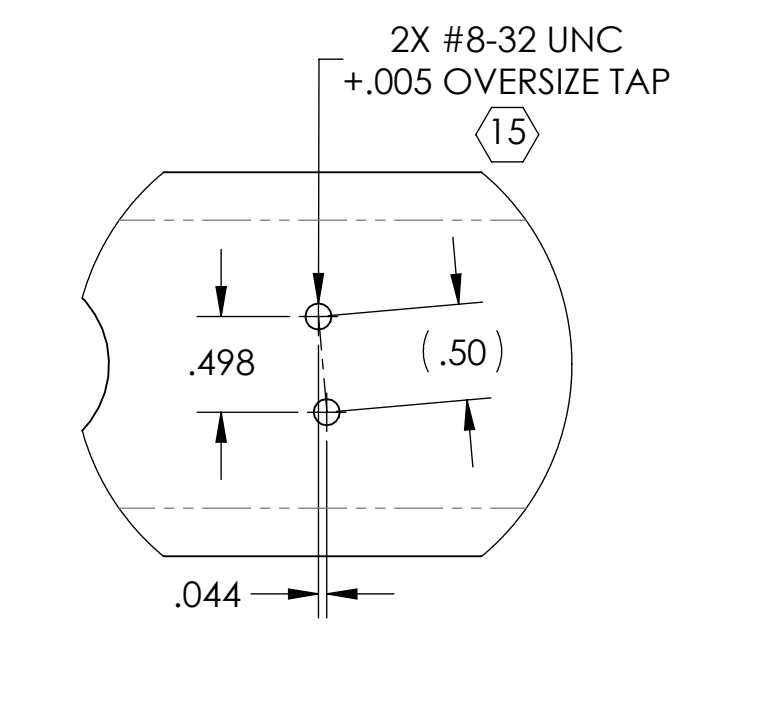

DETAIL S  
SCALE 1 : 1  
2 PLACES

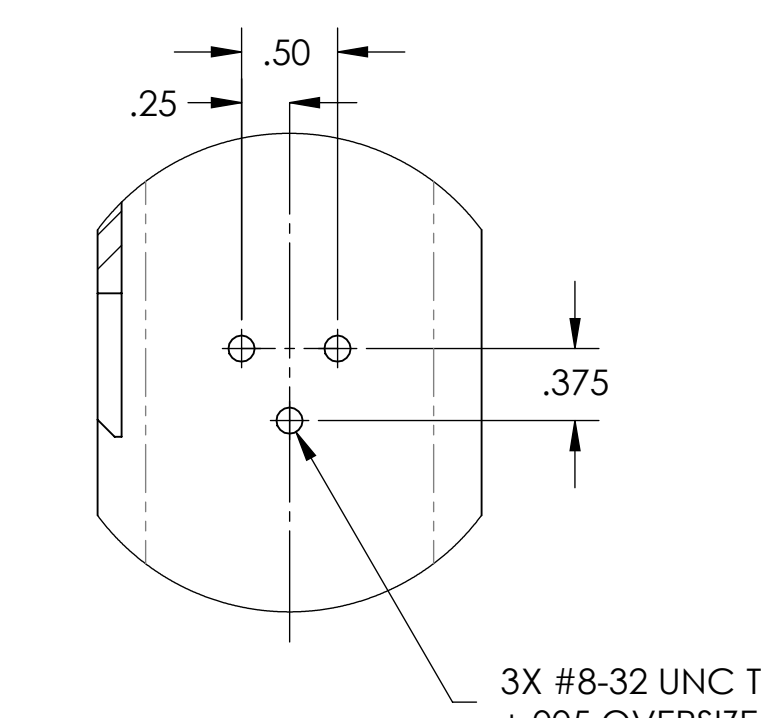

DETAIL T  
SCALE 1 : 1  
4 PLACES