

REV.	DATE	DCN #	DRAWING TREE #
A	28 MAR 2008	E080113-00	
v1	21 APR 2009	E0900107-v1	

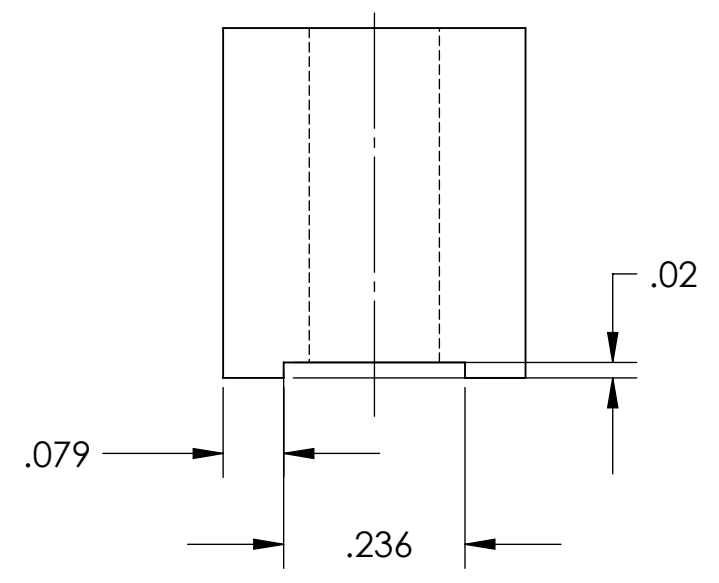
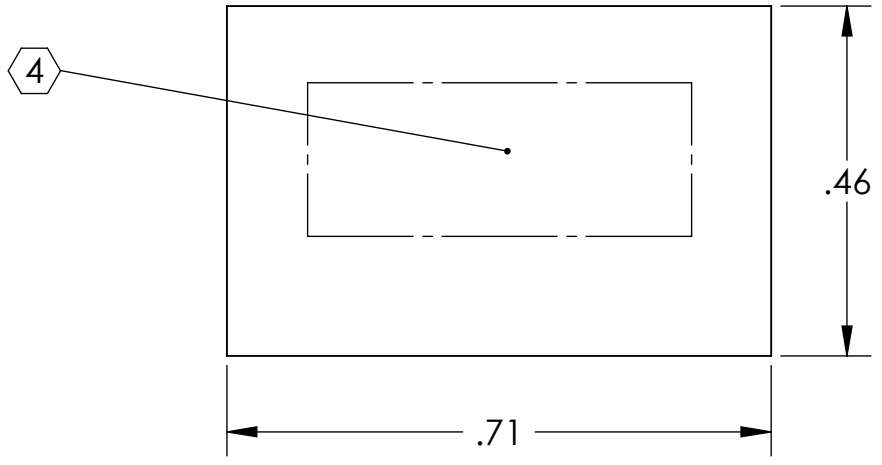
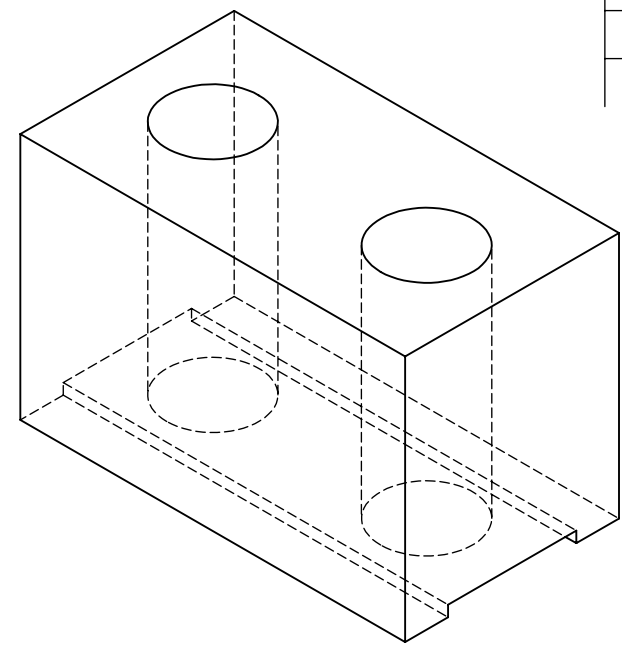
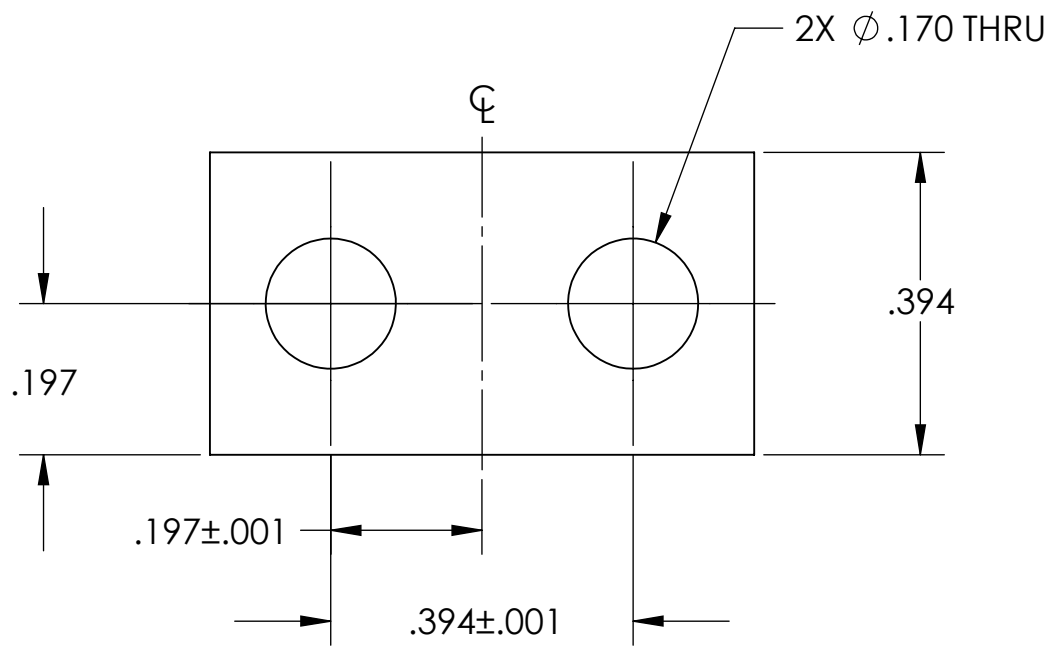

PARTS LIST															
<p><b>NOTES: (UNLESS OTHERWISE SPECIFIED)</b></p> <p>1. DO NOT SCALE FROM DRAWING.            2. REMOVE ALL SHARP EDGES, R.02 MAX.            3. ALL MACHINING FLUIDS SHALL BE WATER SOLUBLE AND FREE OF SULFUR, CHLORINE AND SILICONE.</p> <p>④ SCRIBE, ENGRAVE OR MECHANICALLY STAMP DRAWING (NO INKS OR DYES) PART NUMBER, REVISION ON NOTED SURFACE OF PART FOLLOWED ON THE NEXT LINE WITH A THREE DIGIT SERIAL NUMBER. SERIAL NUMBERS START AT 001 FOR THE FIRST ARTICLE AND PROCEED CONSECUTIVELY. USE .12" HIGH CHARACTERS, UNLESS THE SIZE OF THE PART DICTATES SMALL CHARACTERS. A VIBRATORY TOOL MAY BE USED. EXAMPLE:            D070031-v1            S/N 001</p>		<p>DIMENSIONS ARE IN INCHES</p> <p>TOLERANCES:            .XX ± 0.01            .XXX ± 0.005</p> <p>ANGULAR ± 0.5°</p>													
<p><b>MATERIAL</b>            302, 304 OR 316 SSTL</p>		<p><b>FINISH</b></p>													
<table border="1"> <thead> <tr> <th></th> <th>NAME</th> <th>DATE</th> </tr> </thead> <tbody> <tr> <td>DRAWN</td> <td>D. BRIDGES</td> <td>26 MAR 2008</td> </tr> <tr> <td>CHECKED</td> <td>M. MEYER</td> <td>27 MAR 2008</td> </tr> <tr> <td>APPROVED</td> <td></td> <td></td> </tr> </tbody> </table>			NAME	DATE	DRAWN	D. BRIDGES	26 MAR 2008	CHECKED	M. MEYER	27 MAR 2008	APPROVED			<p><b>SYSTEM</b> ADVANCED LIGO</p> <p><b>SUB-SYSTEM</b> SUS</p> <p><b>NEXT ASSY</b> D060502</p> <p><b>PART NAME</b>            LOWER BLADE CLAMP UPPER SIDE</p>	
	NAME	DATE													
DRAWN	D. BRIDGES	26 MAR 2008													
CHECKED	M. MEYER	27 MAR 2008													
APPROVED															
<p><b>SIZE</b> DWG. NO. D070031</p>		<p><b>REV.</b> v1</p>													
<p>SCALE: 4:1 PROJECTION:  SHEET 1 OF 1</p>															