

REV.	DATE	DCN #	DRAWING TREE #
A	25 MAR 2008	E080113	
B	9 APR 2008	E080154	

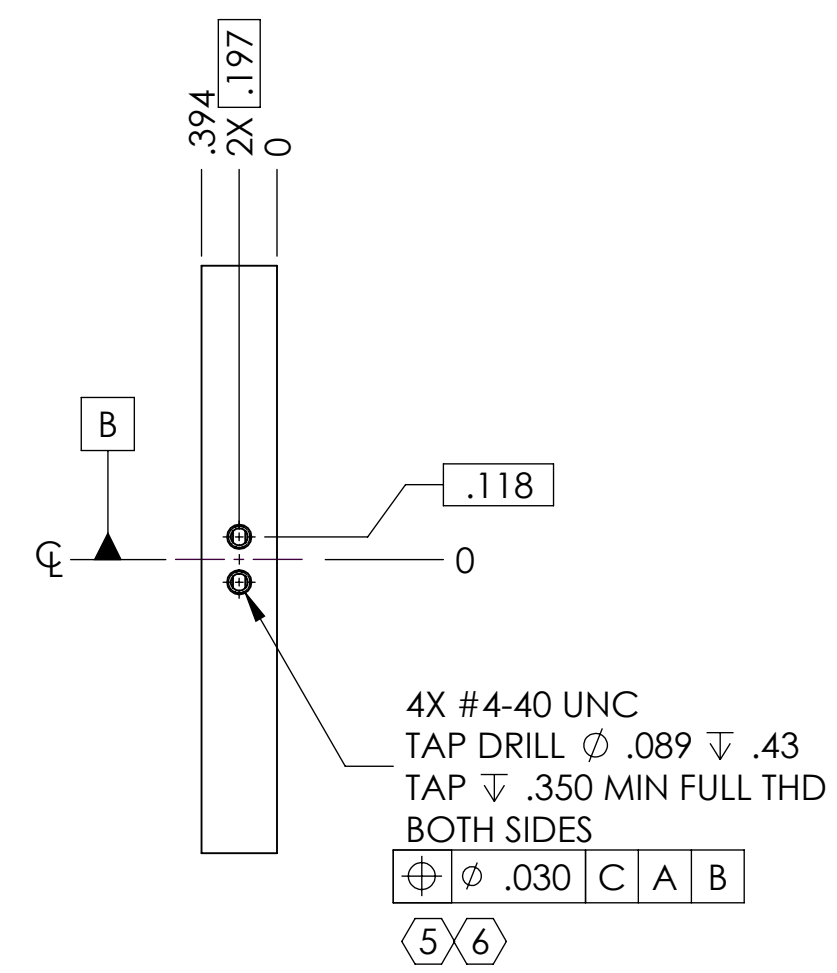
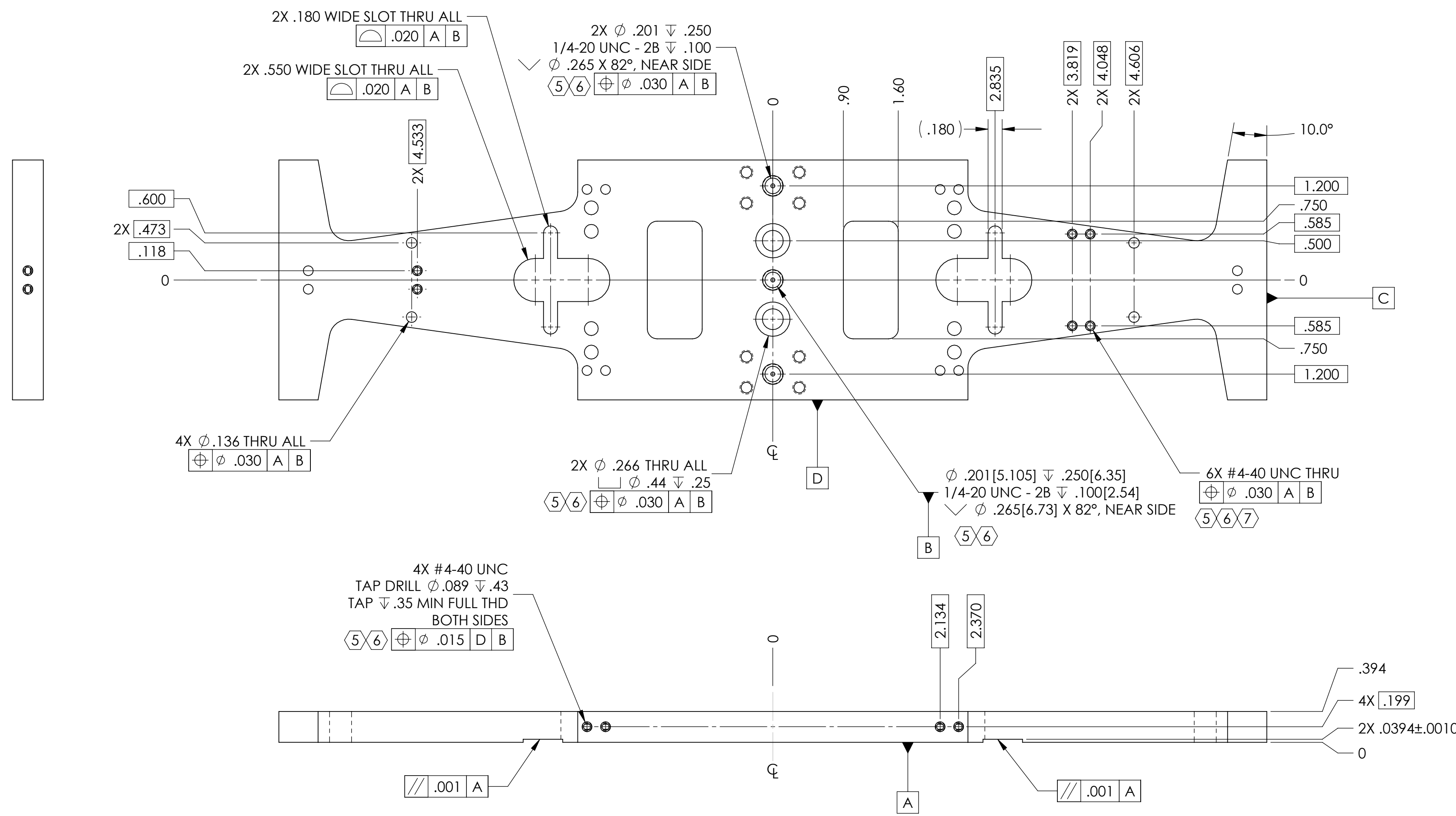
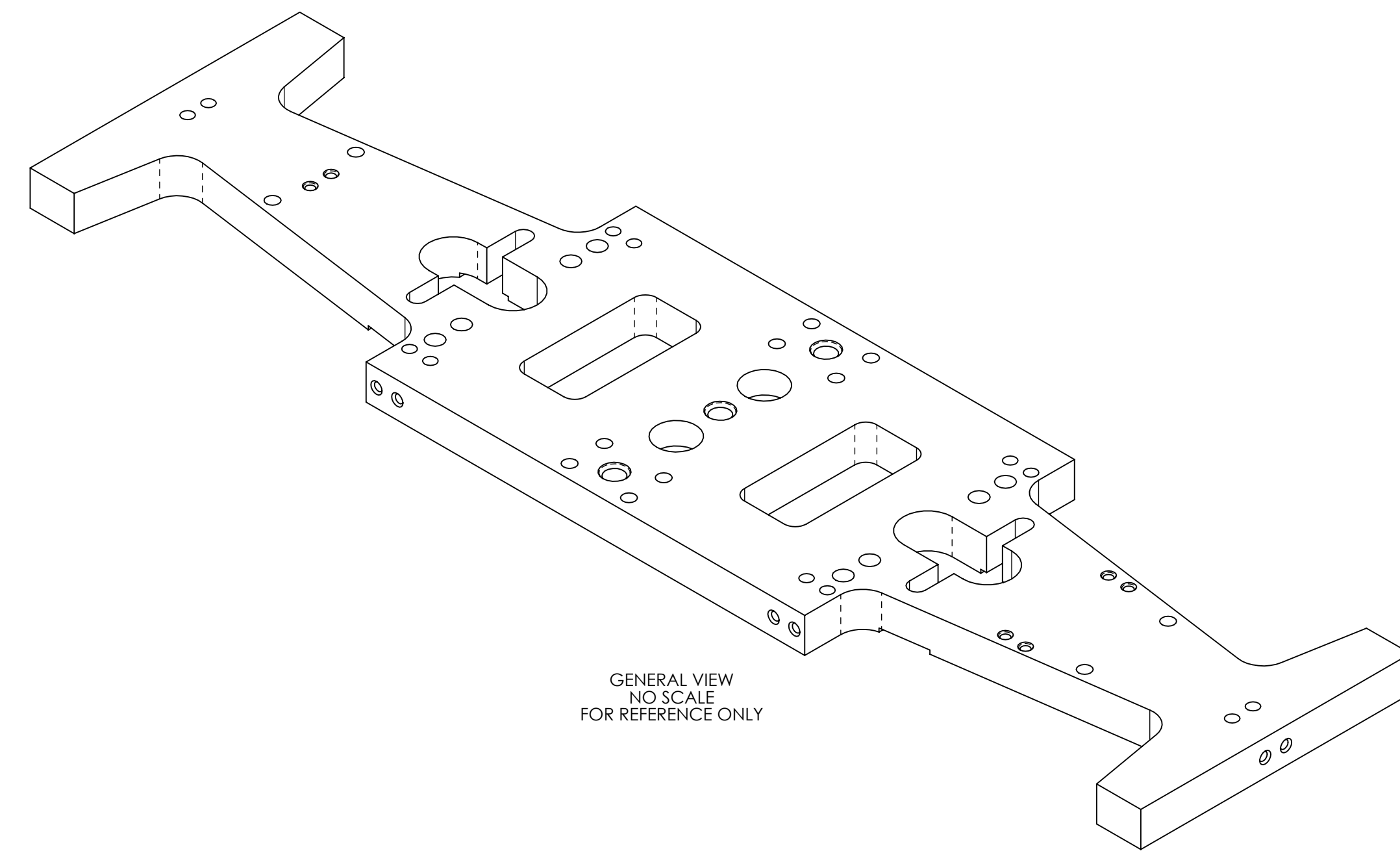
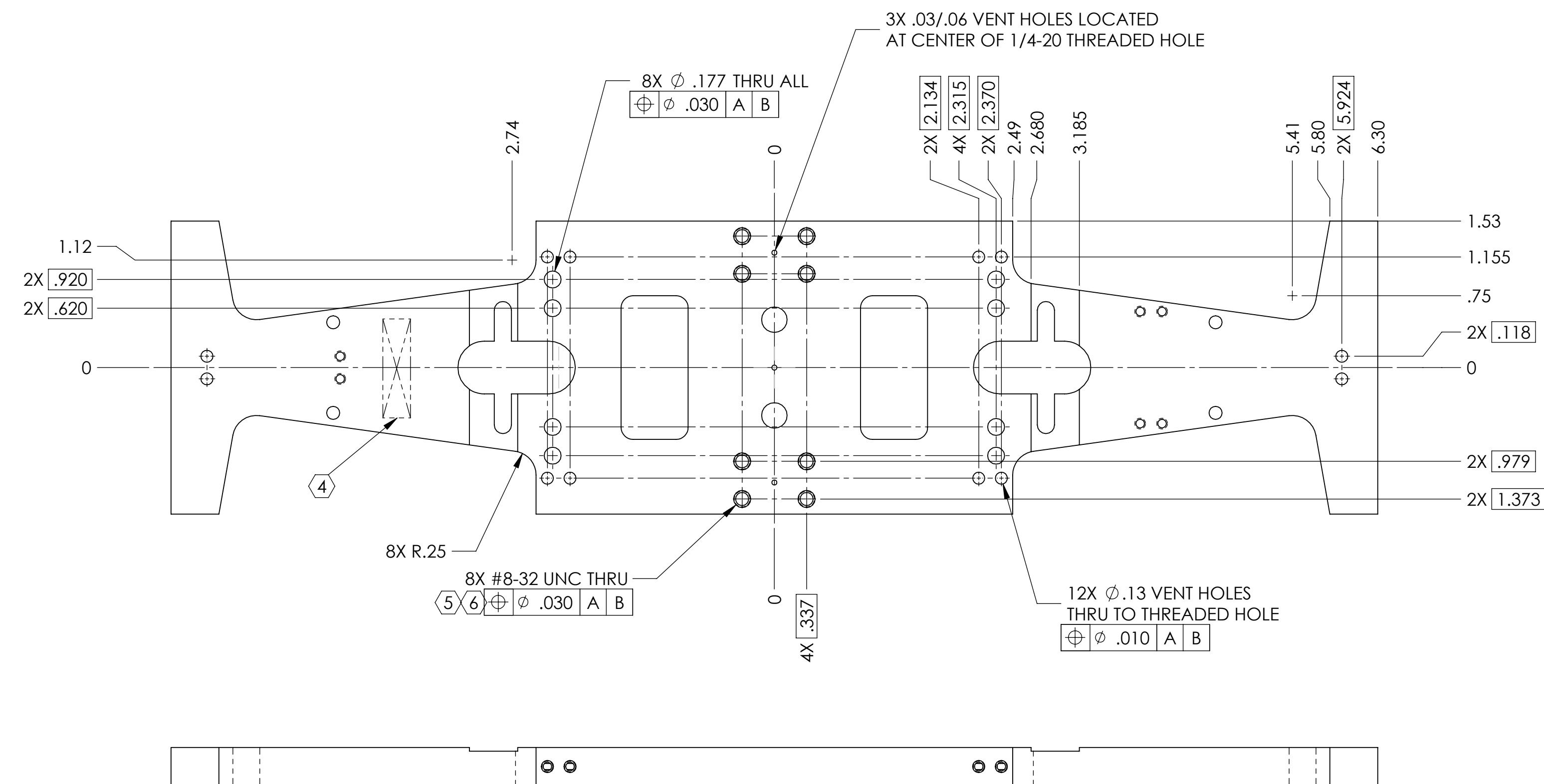

- ADDITIONAL NOTES:
- (5) ALL THREADED HOLES SHALL BE PRODUCED TO A .004 - .006 OVERSIZE CONDITION. TAPS WILL BE PROVIDED BY LIGO.
 - (6) COUNTERSINK 82° ALL TAPPED HOLES TO MAJOR DIAMETER +.015/- .000.
 - (7) PART IS SYMMETRICAL ABOUT TWO PLANES CENTERED AT DATUM B, EXCEPT FOR NOTED FEATURES. INTERPRET DRAWING ACCORDINGLY.
 - (8) RECORD MASS TO NEAREST GRAM ON INSPECTION REPORT AFTER FINAL MACHINING.

NOTES: (UNLESS OTHERWISE SPECIFIED)		PARTS LIST	
1. DO NOT SCALE FROM DRAWING. 2. REMOVE ALL SHARP EDGES, R.02 MAX. 3. ALL MACHINING FLUIDS SHALL BE WATER SOLUBLE AND FREE OF SULFUR, CHLORINE AND SILICONE.		DIMENSIONS ARE IN INCHES TOLERANCES: .XX ± .001 .XXX ± 0.005 ANGULAR ± 0.5°	
4. SCRIBE, ENGRAVE OR MECHANICALLY STAMP (NO INKS OR DYES) PART AND REV ON NOTED SURFACE OF PART FOLLOWED BY THE NEXT LINE WITH A THREE DIGIT SERIAL NO. SERIAL NOS. START AT .001 FOR THE FIRST ASSEMBLY AND PROCEED CONSECUTIVELY. USE 1/2" HIGH CHARACTERS, UNLESS THE SIZE OF THE PART DICTATES SMALLER CHARACTERS. A VIBRATORY TOOL MAY BE USED. EXAMPLE:		MATERIAL: AISI TYPE 303 SS FINISH: 32 μ inch PART NAME: MAIN SECTION, UPPER MASS, OMC NEXT ASSY: D060502	
DRAWN: C. ECHOLS CHECKED: M. MEYER APPROVED:		DATE: 13 FEB 2007 SITE: D DWG. NO.: D060491 SCALE: 1:1 PROJECTION:	
D060502-A 5/1/07		CALIFORNIA INSTITUTE OF TECHNOLOGY MASSACHUSETTS INSTITUTE OF TECHNOLOGY IGR, GLASGOW UNIVERSITY GEO 400 GROUP SYSTEM: ADVANCED LIGO SUB-SYSTEM: SUS SHEET 1 OF 1	