

LTR		ZONE		REVISIONS										DWN	CHK	ENGR	STRESS	MATL	THRM	ME	PROJ	QA	RELEASE DATE
A				INITIAL RELEASE																			

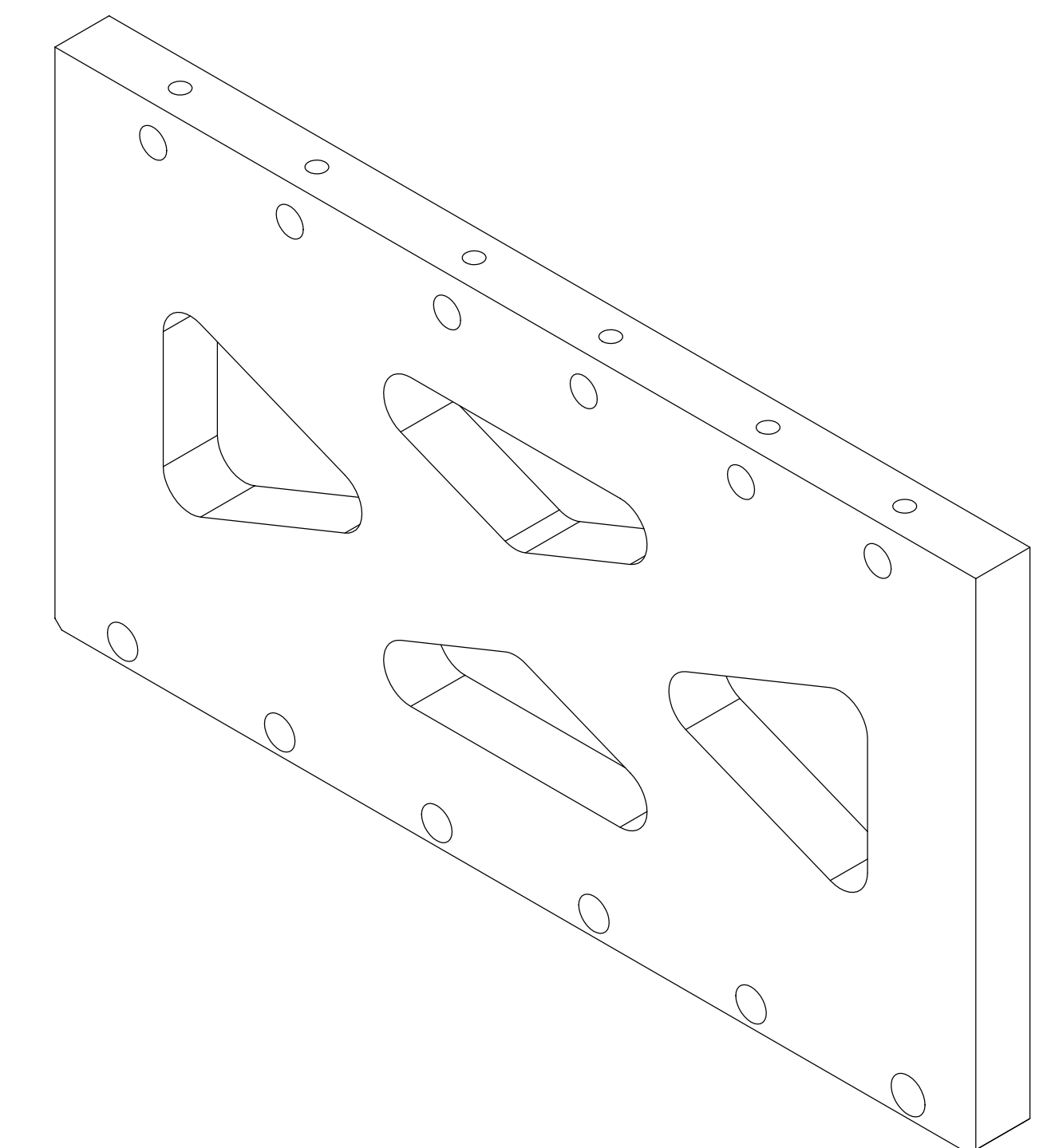
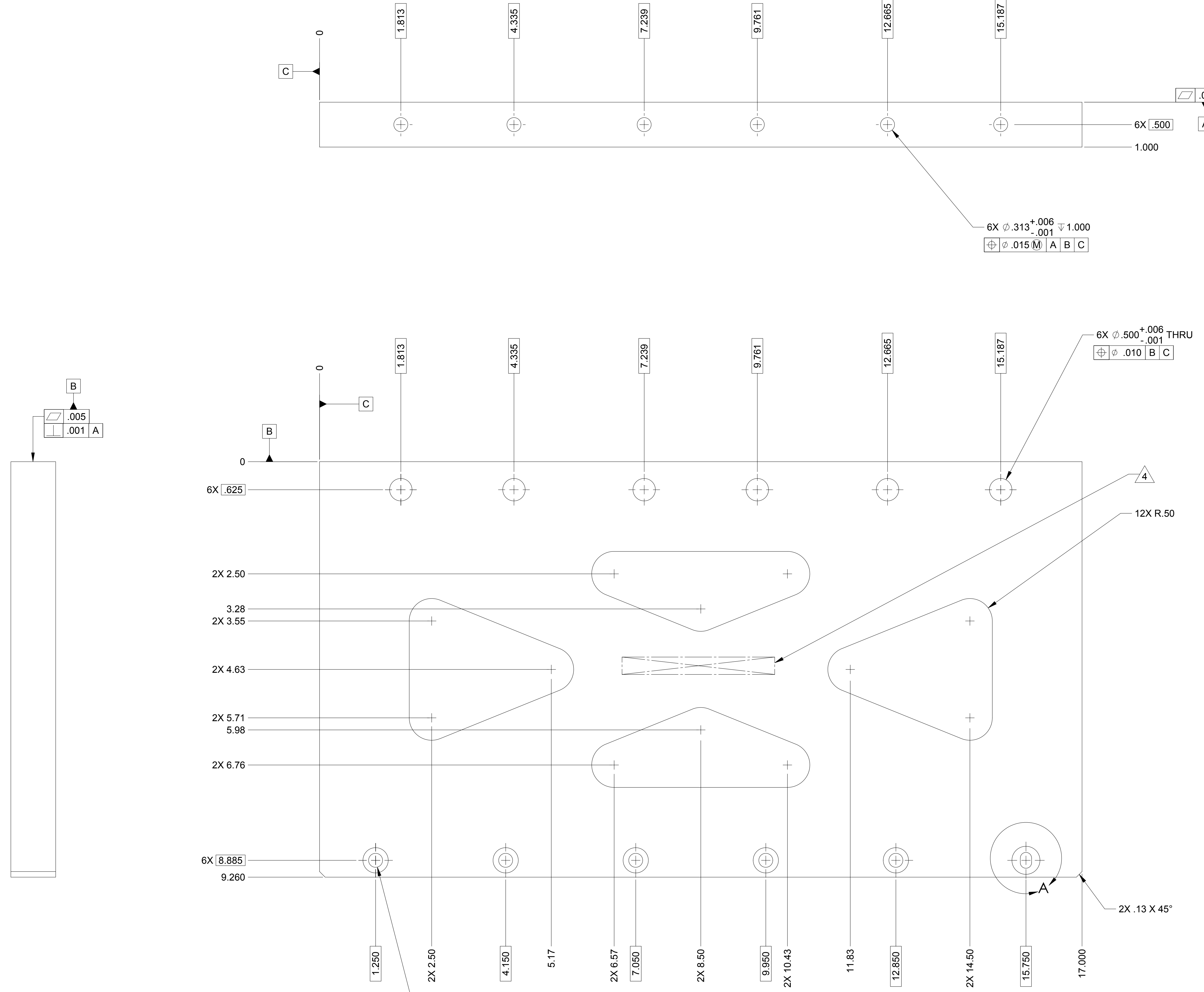

- NOTES: UNLESS OTHERWISE SPECIFIED.
- ALL PARTS SHALL BE MANUFACTURED IN ACCORDANCE WITH ASI SPECIFICATION 20008225 (LIGO E048225).
 - REMOVE ALL BURRS AND SHARP EDGES .005-.015.
 - MACHINE FILLET RADII .003-.015.
 - MARK PART AND SERIAL NUMBER IN LOCATION APPROXIMATELY AS SHOWN USING 0.13-INCH HIGH CHARACTERS IN ACCORDANCE WITH 20006886, TYPE I, CLASSES 4, 5, OR 6. SERIAL NUMBERS START AT 001 FOR FIRST PART AND PROCEED CONSECUTIVELY. PARTS TOO SMALL TO MARK SHALL BE IDENTIFIED IN ACCORDANCE WITH 20006886, TYPE II.
 - COUNTERSINK 82° ALL DRILLED HOLES .015-.030 DEEP BOTH SIDES.
 - RECORD WEIGHT TO NEAREST 0.1 LB ON INSPECTION REPORT AFTER FINAL MACHINING. ESTIMATED WEIGHT IS 12.5 LBS.

QTY	REGD	ITEM NO	REF DES	CAGE NO	PART OR IDENTIFYING NO	NOMENCLATURE OR DESCRIPTION	SPECIFICATION	MATERIAL OR NOTE	ZONE
						20007862-1			

CONTRACT NO		DIMENSIONS ARE IN INCHES		PARTS LIST	
		UNLESS OTHERWISE SPECIFIED	DECIMALS	ANGLES	125
		TOLERANCES	XX ±.03	XXX ±.010	±12°
		MACHINE FINISH	DO NOT SCALE DRAWING		
			INTERPRET DWG PER ASME Y14.5M, 1994		
		MATERIAL	AL ALY 6061-T651		
			AMS QQ-A-250/11		

FILE ATTACHMENTS	CONTRACT NO	ITEM NO	REF DES	CAGE NO	PART OR IDENTIFYING NO	NOMENCLATURE OR DESCRIPTION	SPECIFICATION	MATERIAL OR NOTE	ZONE
20007862.X_L	20007845	1388				PLATE, KEEL TABLE BRACE - STAGE 2			

SIZE	CAGE CODE	SCALE	UNCLASSIFIED	SHEET 1 OF 1
E	1KNU9	1:1		

THIS DOCUMENT MAY CONTAIN ITAR CONTROLLED INFORMATION AND/OR COMMERCE CONTROLLED INFORMATION EXPORT RESTRICTIONS MAY APPLY

DETAIL A
SCALE 2:1