

NOTES CONTINUED:

5. SCRIBE, ENGRAVE, OR MECHANICALLY STAMP (NO INKS OR DYES) DRAWING PART NUMBER, REVISION (AND VARIANT OR "TYPE" IF APPLICABLE) ON NOTED SURFACE OF PART FOLLOWED ON THE NEXT LINE WITH A THREE DIGIT SERIAL NUMBER. SERIAL NUMBERS START AT 101 FOR THE FIRST ARTICLE AND PROCEED CONSECUTIVELY. USE MINIMUM 0.12" HIGH CHARACTERS, UNLESS THE SIZE OF THE PART DICTATES SMALLER CHARACTERS. A VIBRATORY TOOL MAY BE USED.

6. APPROXIMATE WEIGHT = 0.289 LB.
7. MACHINE ALL SURFACES TO REMOVE OXIDES AND MILL FINISH. USE OF ABRASIVE REMOVAL TECHNIQUES IS NOT ALLOWED.
8. ALL PARTS SHALL BE MANUFACTURED IN ACCORDANCE WITH LIGO SPECIFICATION E0900364.

9. SCRIBE, ENGRAVE, OR MECHANICALLY STAMP (NO INKS OR DYES) AS MARKED ON NOTED SURFACE. USE .12" HIGH CHARACTERS.

10. DO NOT REMOVE SHARP EDGES.

REV.	DATE	DCN #	DRAWING TREE #
A	24 JUN 2004	E0400303-00	-
v1	21 APR 2009	E0900107-v1	-
v2	25 JUN 2010	E0900424	E0900353

D

D

C

C

B

B

A

A

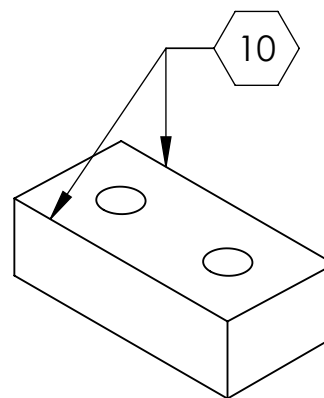
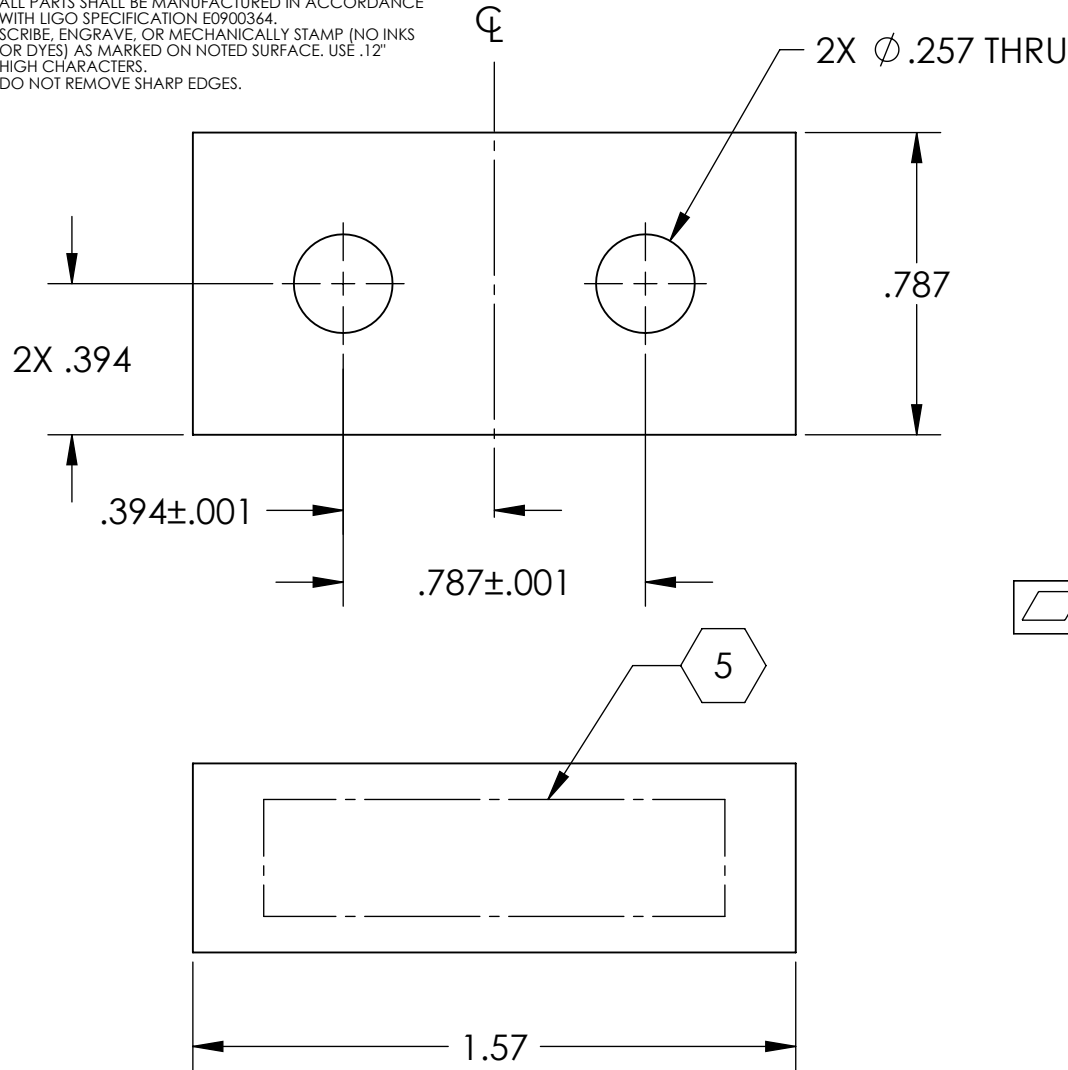

ISOMETRIC VIEW

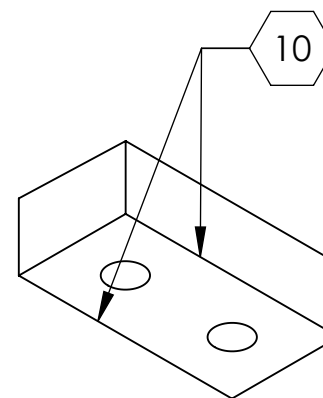

REVERSE ISOMETRIC VIEW

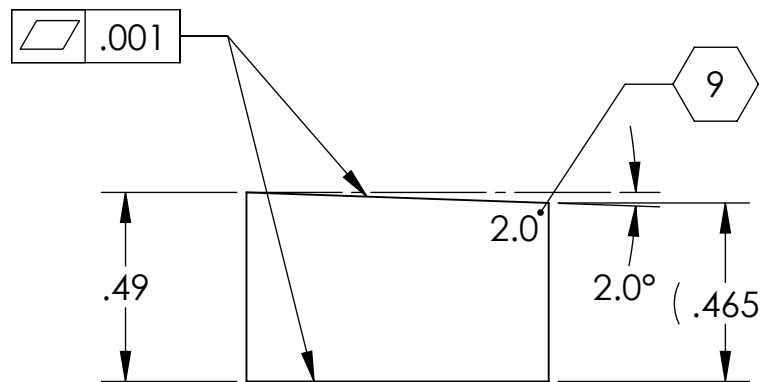

NOTES AND TOLERANCES: (UNLESS OTHERWISE SPECIFIED)

DIMENSIONS ARE IN INCHES

TOLERANCES:
.XX ± .03
.XXX ± .005

ANGULAR ± 0.2°

1. INTERPRET DRAWING PER ASME Y14.5-1994.
2. REMOVE ALL SHARP EDGES, R.02 MIN.
3. DO NOT SCALE FROM DRAWING.
4. ALL MACHINING FLUIDS MUST BE FULLY SYNTHETIC, FULLY WATER SOLUBLE AND FREE OF SULFUR, SILICONE, AND CHLORINE.

MATERIAL 304, 316 OR 302 SSSL
FINISH 32 μinch

LIGO CALIFORNIA INSTITUTE OF TECHNOLOGY
MASSACHUSETTS INSTITUTE OF TECHNOLOGY

SYSTEM **ADVANCED LIGO** SUB-SYSTEM **SUS**

NEXT ASSY **D020677**

PART NAME **UPPER BLADE CLAMP, LOWER SIDE 2.0 DEGREE**

DESIGNER	C. TORRIE	01 MAY 2002	SIZE	DWG. NO.	REV.
DRAFTER	B. MOORE	25 MAY 2010	A	D030463	v2
CHECKER	M. MEYER	01 JUN 2010	SCALE: 2:1	PROJECTION:	SHEET 1 OF 1
APPROVAL					