

REV.	DATE	DCN #	DRAWING TREE #
A	24 JUN 2004	E040303-00	
v1	21 APRIL 2009	E0900107-v1	

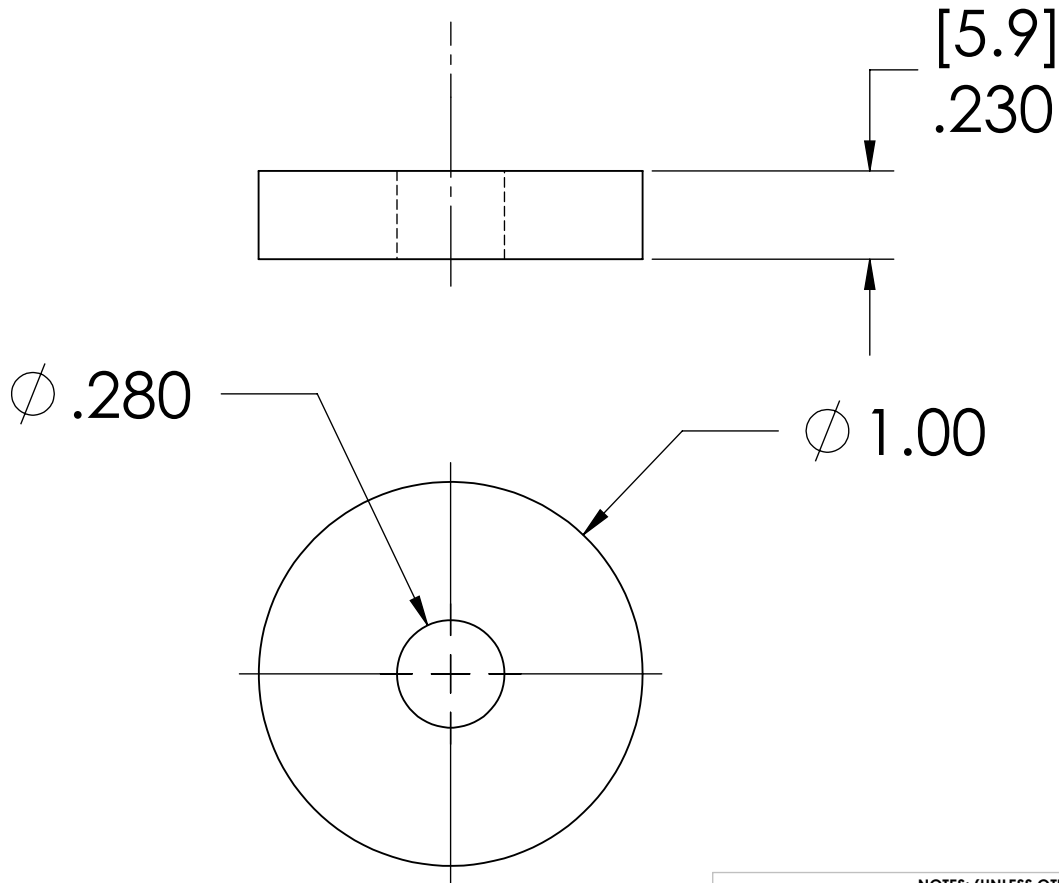

**NOTES: (UNLESS OTHERWISE SPECIFIED)**

1. DO NOT SCALE FROM DRAWING.
2. REMOVE ALL SHARP EDGES, R.02 MAX.
3. ALL MACHINING FLUIDS SHALL BE WATER SOLUBLE AND FREE OF SULFUR, CHLORINE AND SILICONE.
4. BAG ALL ITEMS INDIVIDUALLY AND TAG EACH BAG WITH THE DRAWING NUMBER AND REVISION e.g. D030078-00.

DIMENSIONS ARE IN INCHES [mm]

TOLERANCES:

.XX  $\pm 0.01$   
.XXX  $\pm 0.005$

ANGULAR  $\pm 0.5^\circ$

**MATERIAL**  
302, 304 OR 316 SSTL

**FINISH**

	NAME	DATE
<b>DRAWN</b>	C. TORRIE	28 JUN 2002
<b>CHECKED</b>	D. BRIDGES	25 APR 2008
<b>APPROVED</b>		



**SYSTEM** ADVANCED LIGO

**SUB-SYSTEM** SUS

**NEXT ASSY** MC: UPPER MASS

**PART NAME** UPPER MASS  
20g ADD ON MASS

**SIZE** A **DWG. NO.** D030078 **REV.** v1

**SCALE:** 2:1 **PROJECTION:** **SHEET 1 OF 1**