

REV.	DATE	DCN #	DRAWING TREE #
A	24 JUN 2004	E040303-00	
B	9 APR 2008	E080156-00	

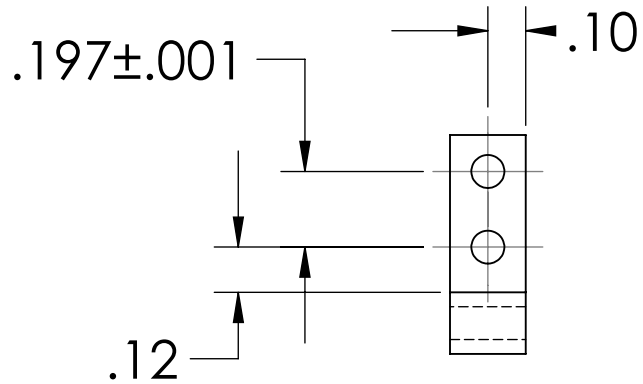

4X, 2-56 UNC-2B

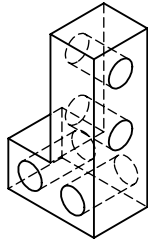
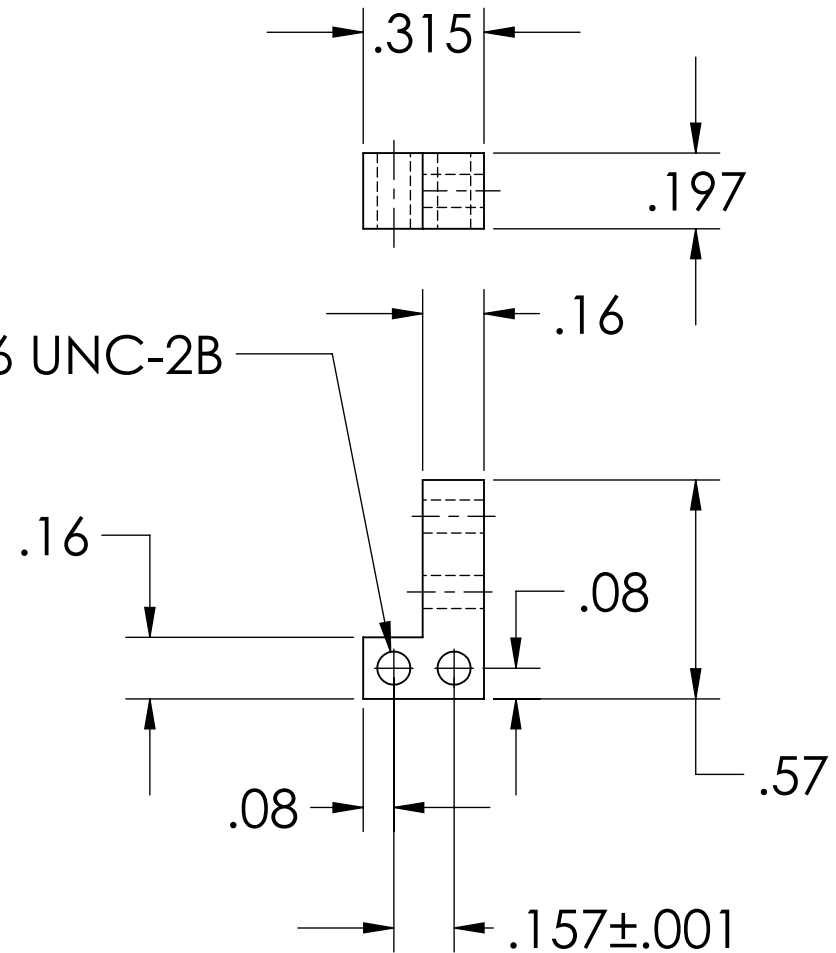

NOTES: (UNLESS OTHERWISE SPECIFIED)

- DO NOT SCALE FROM DRAWING.
- REMOVE ALL SHARP EDGES, R.02 MAX.
- ALL MACHINING FLUIDS SHALL BE WATER SOLUBLE AND FREE OF SULFUR, CHLORINE AND SILICONE.
- BAG ALL ITEMS INDIVIDUALLY AND TAG EACH BAG WITH THE PART NUMBER, REVISION AND QUANTITY.  
EXAMPLE: D020132-00  
QTY: TBD

DIMENSIONS ARE IN INCHES

TOLERANCES:

.XX ± 0.01

.XXX ± 0.005

ANGULAR ± 0.5 °

MATERIAL  
300 SERIES STAINLESS

FINISH

	NAME	DATE
DRAWN	C TORRIE	04/02
CHECKED	D BRIDGES	26 MAR 2008
APPROVED		



SYSTEM ADVANCED LIGO

SUB-SYSTEM SUS

NEXT ASSY MC UPPER MASS

PART NAME  
LOWER BLADE WIRE CLAMP

SIZE DWG. NO. D020132 REV. B

SCALE: NTS PROJECTION: SHEET 1 OF 1