

Serial Number: _____

Date: _____

Tech: _____

LASER INTERFEROMETER GRAVITATIONAL WAVE OBSERVATORY

-LIGO-

CALIFORNIA INSTITUTE OF TECHNOLOGY

MASSACHUSETTS INSTITUTE OF TECHNOLOGY

Document Type	DCC Number	December 19, 2008
	T080021-v2	
UK UIM Driver Pre-Production Prototype Test Plan		
J. Heefner		

Distribution of this draft:
This is an internal working note of the LIGO Laboratory

California Institute of Technology	Massachusetts Institute of Technology
LIGO Project – MS 18-33	LIGO Project – MS 20B-145
Pasadena, CA 91125	Cambridge, MA 01239
Phone (626) 395-2129	Phone (617) 253-4824
Fax (626) 304-9834	Fax (617) 253-7014
E-mail: info@ligo.caltech.edu	E-mail: info@ligo.mit.edu

www: <http://www.ligo.caltech.edu/>

Serial Number: _____

Date: _____

Tech: _____

1 Introduction

The tests described below will be utilized to test the Pre-production prototype of the AdL Quad Suspension UIM Coil Driver. These drivers are being designed and build by the UK group located at the University of Birmingham. The design requirements for the driver can be found in LIGO document number T060067-00-C, “AdL Quad Suspension UK Coil Driver Design Requirements”. The schematic for the UIM Coil Driver is LIGO document number D070481-03-K. The schematic for the Noise Monitor Board is LIGO document number D070480-03-K.

These tests are not comprehensive and will only be utilized to verify that the driver meets the design requirements. It is assumed that the drivers have been thoroughly tested by the University of Birmingham prior to shipment.

2 Test Equipment

- Stanford Research SR785 analyzer
- Voltmeter
- Oscilloscope
- Board Schematics- TBD

3 Tests

The tests are broken into the same categories used in the design requirements document, noise, dynamic range and monitors/controls. The tests for each of these categories are described in the sections below.

3.1 Dynamic Range and Transfer Function Tests

Each channel of the UIM coil driver is equipped with three relays that are used to change the response from a very high dynamic range high noise to a low dynamic range, low noise response. In reality, these relays (K1, K3 and K4) are switched in one at a time, but in the interest of conserving test time only the extremes of the four possible modes are tested. The high dynamic range mode does not have any of the relays energized and the low noise mode has all relays energized. The tests for each of these two modes are described in the sections that follow. Note that it has been assumed that the actual response of each individual mode has been tested by the UK group prior to delivery of the unit. The transfer function for each mode of operation is measured by injecting a signal into the test input of a channel and measuring the current through a 20 ohm resistor connected across the corresponding channel output. Measurements are made for frequencies from 0.1Hz to 10KHz. A block diagram of the test setup is shown in the figure below.

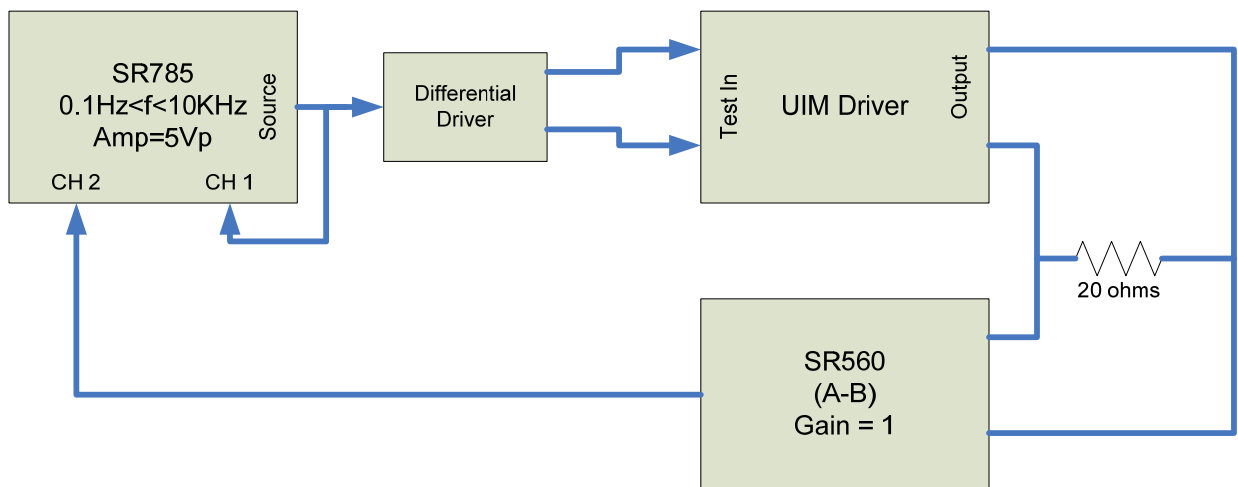

Serial Number: _____

Date: _____

Tech: _____

3.1.1 High Dynamic Range Mode

In the high dynamic range mode, relays K1, K3 and K4 are NOT energized. The nominal response of the coil driver this mode is a zero at 60Hz and a pole at 325Hz and is shown in the plot below. Note that the transfer function is in units of volts in to amps output into a 20 ohm load.

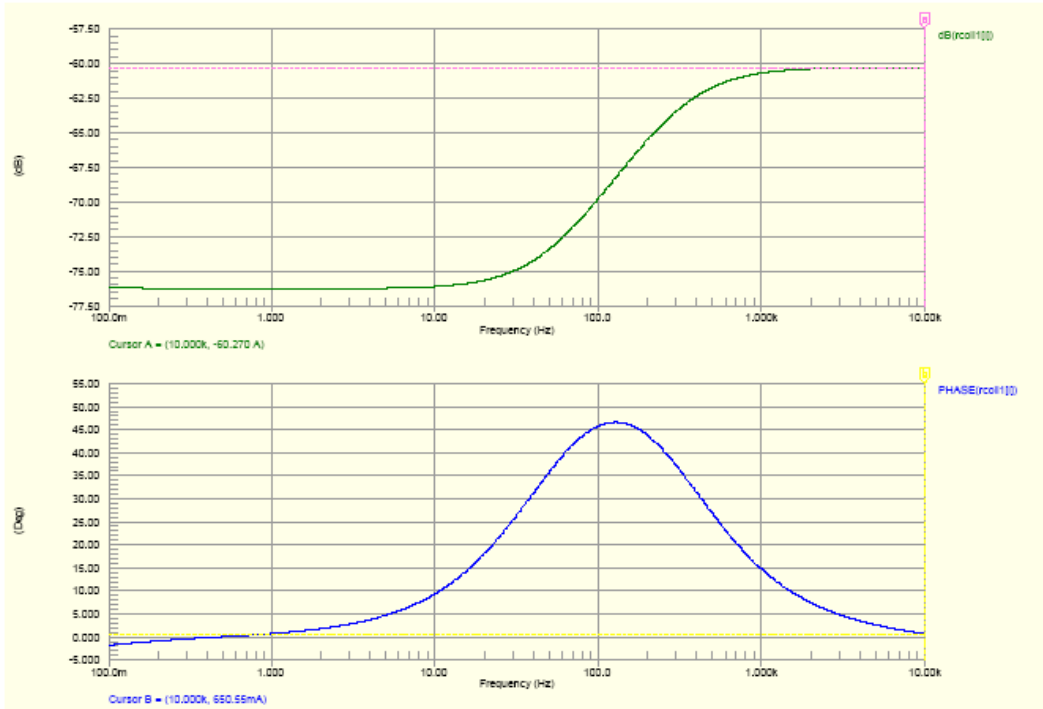

Figure 1: High Dynamic Range Transfer Function

In the tables below, record the measured magnitude and phase of the response for each channel. In addition, save the transfer function for one representative channel to disk and record the file name in space provided below.

Table 1: Channel 1 Transfer Function Measurements

Freq (Hz)	Nominal Gain (dBamps/Volt)	Nominal Phase (Degrees)	Actual Gain (dBamps/Volt)	Actual Phase (Degrees)
0.1	-76.2	-1.8		
1	-76.2	0.7		
10	-76.2	9.4		
100	-69.8	45.8		
1K	-60.7	14.8		
10K	-60.3	0.7		

Table 2: Channel 2 Transfer Function Measurements

Freq (Hz)	Nominal Gain (dBamps/Volt)	Nominal Phase (Degrees)	Actual Gain (dBamps/Volt)	Actual Phase (Degrees)
0.1	-76.2	-1.8		

Serial Number: _____

Date: _____

Tech: _____

1	-76.2	0.7		
10	-76.2	9.4		
100	-69.8	45.8		
1K	-60.7	14.8		
10K	-60.3	0.7		

Table 3: Channel 3 Transfer Function Measurements

Freq (Hz)	Nominal Gain (dBamps/Volt)	Nominal Phase (Degrees)	Actual Gain (dBamps/Volt)	Actual Phase (Degrees)
0.1	-76.2	-1.8		
1	-76.2	0.7		
10	-76.2	9.4		
100	-69.8	45.8		
1K	-60.7	14.8		
10K	-60.3	0.7		

Table 4: Channel 4 Transfer Function Measurements

Freq (Hz)	Nominal Gain (dBamps/Volt)	Nominal Phase (Degrees)	Actual Gain (dBamps/Volt)	Actual Phase (Degrees)
0.1	-76.2	-1.8		
1	-76.2	0.7		
10	-76.2	9.4		
100	-69.8	45.8		
1K	-60.7	14.8		
10K	-60.3	0.7		

File Name for transfer function measurement (High Dynamic Range Mode): _____

3.1.2 Low Noise Mode

In the acquire mode, relay K1, K3 and K4 are energized. The nominal response of the coil driver in low noise mode is three poles at 1Hz, three zeros at 10Hz, one zero at 60Hz and one pole at 325Hz. The nominal response is shown in the plot below. Note that the transfer function is in units of volts in to amps output into a 20 ohm load.

Serial Number: _____

Date: _____

Tech: _____

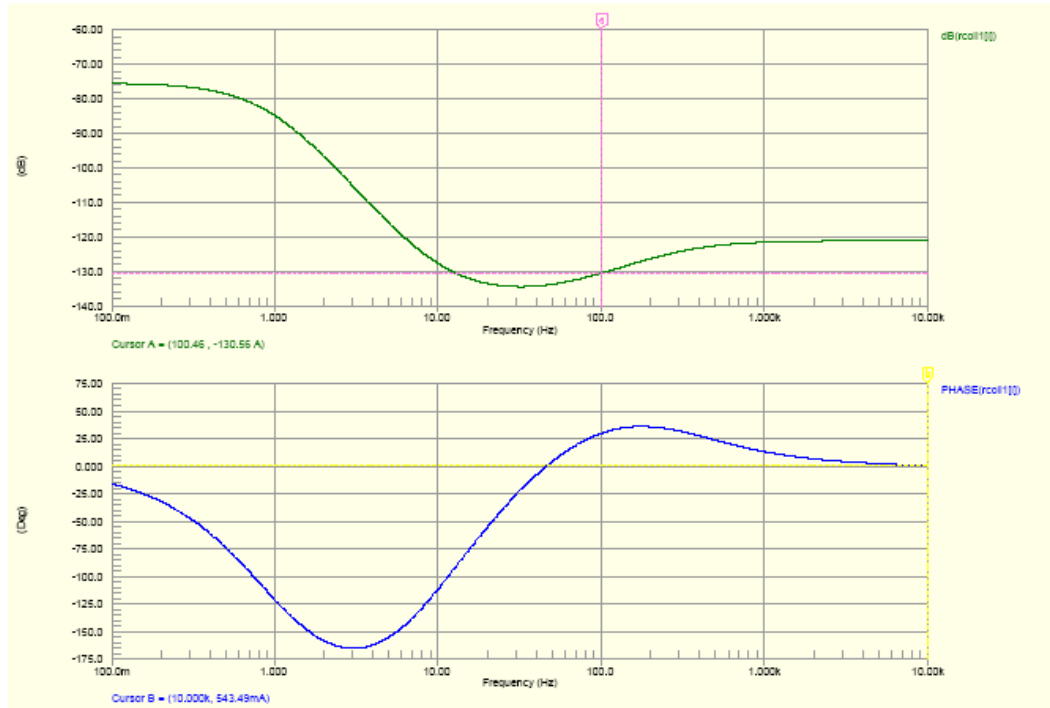

Figure 2: Low Noise Transfer Function

In the tables below, record the measured magnitude and phase of the response for each channel. In addition, save the transfer function for one representative channel to disk and record the file name in space provided below.

Table 5: Channel 1 Transfer Function Measurements

Freq (Hz)	Nominal Gain (dBamps/Volt)	Nominal Phase (Degrees)	Actual Gain (dBamps/Volt)	Actual Phase (Degrees)
0.1	-75.5	-16.1		
1	-84.9	-120.8		
10	-127.8	-111.2		
100	-130.5	29.9		
1K	-121.6	13.2		
10K	-121.2	0.5		

Table 6: Channel 2 Transfer Function Measurements

Freq (Hz)	Nominal Gain (dBamps/Volt)	Nominal Phase (Degrees)	Actual Gain (dBamps/Volt)	Actual Phase (Degrees)
0.1	-75.5	-16.1		
1	-84.9	-120.8		
10	-127.8	-111.2		
100	-130.5	29.9		
1K	-121.6	13.2		
10K	-121.2	0.5		

Serial Number: _____

Date: _____

Tech: _____

Table 7: Channel 3 Transfer Function Measurements

Freq (Hz)	Nominal Gain (dBamps/Volt)	Nominal Phase (Degrees)	Actual Gain (dBamps/Volt)	Actual Phase (Degrees)
0.1	-75.5	-16.1		
1	-84.9	-120.8		
10	-127.8	-111.2		
100	-130.5	29.9		
1K	-121.6	13.2		
10K	-121.2	0.5		

Table 8: Channel 4 Transfer Function Measurements

Freq (Hz)	Nominal Gain (dBamps/Volt)	Nominal Phase (Degrees)	Actual Gain (dBamps/Volt)	Actual Phase (Degrees)
0.1	-75.5	-16.1		
1	-84.9	-120.8		
10	-127.8	-111.2		
100	-130.5	29.9		
1K	-121.6	13.2		
10K	-121.2	0.5		

File Name for transfer function measurement (Low Noise Mode): _____

Channel Number for saved file: _____

3.1.3 Dynamic Range Tests

The maximum output current requirement for the driver is $\pm 2\text{mA}_{\text{rms}}$ for frequencies less than 1Hz. The tests below will verify that the design meets this requirement. In addition the chassis and components will be checked for overheating. The tests for all channels should be conducted simultaneously and each test step/reading should be held for a minimum of 5 minutes to allow the temperature of the chassis and components to stabilize. In the tables below, record the output current versus input voltage (DC), note any component heating and if possible the temperature of the component. Output current should be measured across the 20 ohm load resistor connected to the channel under test. In an effort to save test setup and execution time, this test may be conducted in conjunction with the current monitor testing described in section 3.4.3 below.

Table 9: Channel 1 Output Current vs. Input Voltage

Input Voltage	Nominal Output Current (mA)	Actual Output Current (mA)	Notes
+1V	0.17		
-1V	-0.17		
+5V	0.84		
-5V	-0.84		
+10V	1.67		
-10V	-1.67		
+20V	3.35		
-20V	-3.35		

Serial Number: _____

Date: _____

Tech: _____

Table 10: Channel 2 Output Current vs. Input Voltage

Input Voltage	Nominal Output Current (mA)	Actual Output Current (mA)	Notes
+1V	0.17		
-1V	-0.17		
+5V	0.84		
-5V	-0.84		
+10V	1.67		
-10V	-1.67		
+20V	3.35		
-20V	-3.35		

Table 11: Channel 3 Output Current vs. Input Voltage

Input Voltage	Nominal Output Current (mA)	Actual Output Current (mA)	Notes
+1V	0.17		
-1V	-0.17		
+5V	0.84		
-5V	-0.84		
+10V	1.67		
-10V	-1.67		
+20V	3.35		
-20V	-3.35		

Table 12: Channel 4 Output Current vs. Input Voltage

Input Voltage	Nominal Output Current (mA)	Actual Output Current (mA)	Notes
+1V	0.17		
-1V	-0.17		
+5V	0.84		
-5V	-0.84		
+10V	1.67		
-10V	-1.67		
+20V	3.35		
-20V	-3.35		

3.2 Noise Tests

The most stringent noise requirement for the UIM Driver comes at 10Hz where the output noise current from the driver needs to be less than $3 \text{ pA}/\sqrt{\text{Hz}}$. Measuring the actual noise current into the 20 ohm load resistor is a very difficult measurement, so the noise current must be implied by measuring the output noise voltage of the driver using test points on the board (TP7 and TP11). The total series impedance in the output of the driver including the 20 ohm load is 7.8 Kohms at 10Hz. This means that the output voltage noise measured between TP7 and TP11 needs to be less than $23.4 \text{ nV}/\sqrt{\text{Hz}}$ at 10Hz. A plot of the simulated noise versus frequency is shown in the figure below.

Serial Number: _____

Date: _____

Tech: _____

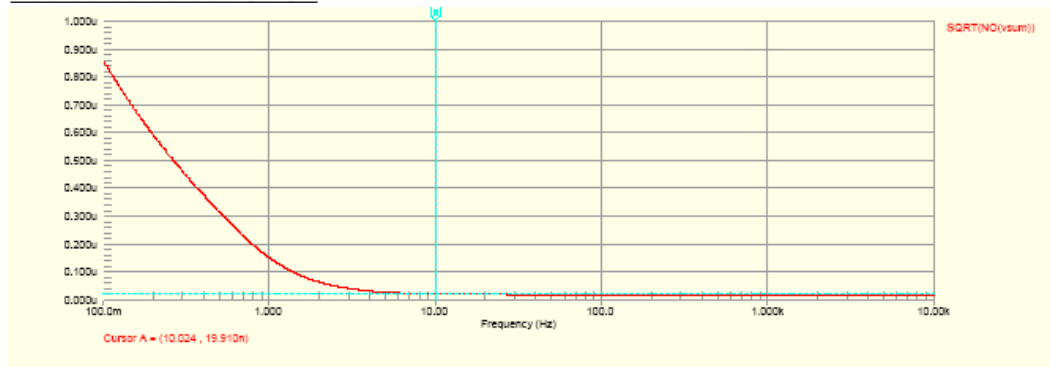

Figure 3: Output Noise as measured between TP7 and TP11

The simulation predicts that the noise at 10Hz should be approximately $20\text{nV}/\sqrt{\text{Hz}}$. In the table below, record the output noise at 10Hz measured between TP7 and TP11 for each channel. The inputs to the channel under test should be tied to circuit ground and relays K1, K3 and K4 should be energized (Low Noise Mode). In addition, save the noise data for one representative channel to disk and record the file name in space provided below. The frequency range for the saved file should be from 0.1Hz to 100Hz.

Channel Number	Measured Noise at 10Hz
1	
2	
3	
4	

File Name for noise measurement (Low Noise Mode): _____

Channel Number for saved file: _____

3.3 Crosstalk Tests

In this set of tests the crosstalk from one channel to another is measured. The measurement is made by measuring the transfer function from the input of one channel to the noise monitor output of adjacent channels. The noise monitor is used because it is a convenient measurement point and it provides a high gain, AC coupled measurement of the voltage output of the channel. The test setup is shown in the figure below. The driver channels should be setup for Low Noise operation, i.e. relays K1, K3 and K4 for all channels energized.

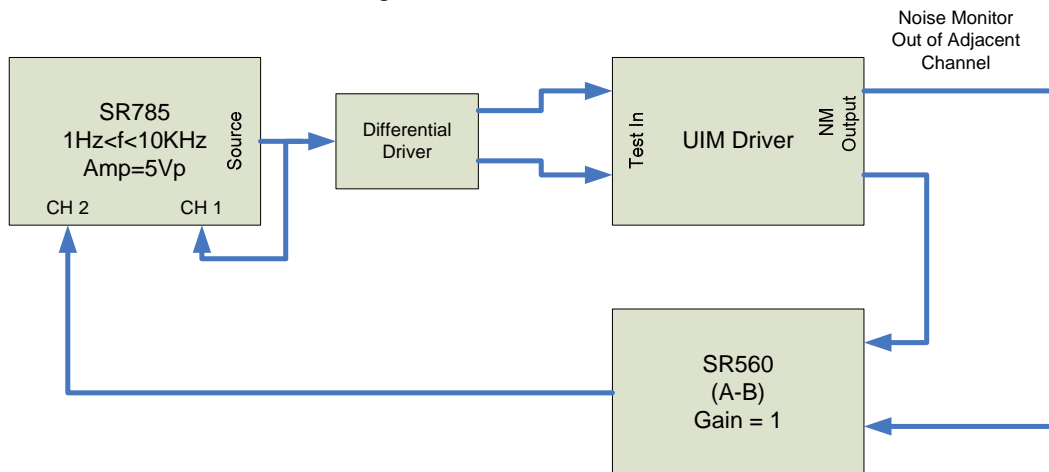

Serial Number: _____

Date: _____

Tech: _____

The inputs to the unused driver channels should be tied to circuit ground, the coil driver outputs should be loaded with 20 ohms and the transfer function from each channel to the noise monitor output of the adjacent channels should be measured. The transfer function showing the highest cross coupling should be stored to a file. The file name is recorded in the space below.

File Name for Crosstalk Measurement: _____

Input and output channel numbers for saved file: _____

3.4 Monitors, Controls and Circuit Protection

3.4.1 Noise Monitor Transfer Function Tests

The noise monitor board in the driver chassis provides a low-noise, AC coupled monitor of the voltage output of each channel. The nominal transfer function of the monitor is 4 zeros at DC, 4 poles at 5Hz and 2 poles at 5KHz which are added to the response of the driver channel. These tests measure the transfer function from the input of a particular driver channel to the corresponding noise monitor output. The coil driver output should be load with 20 ohms during the tests. The test setup for the measurements is the same as that for the crosstalk measurements with the exception that the noise monitor used is the monitor for the channel under test. Relays K1, K3 and K4 should be energized during the tests. The figure below shows the response nominal response.

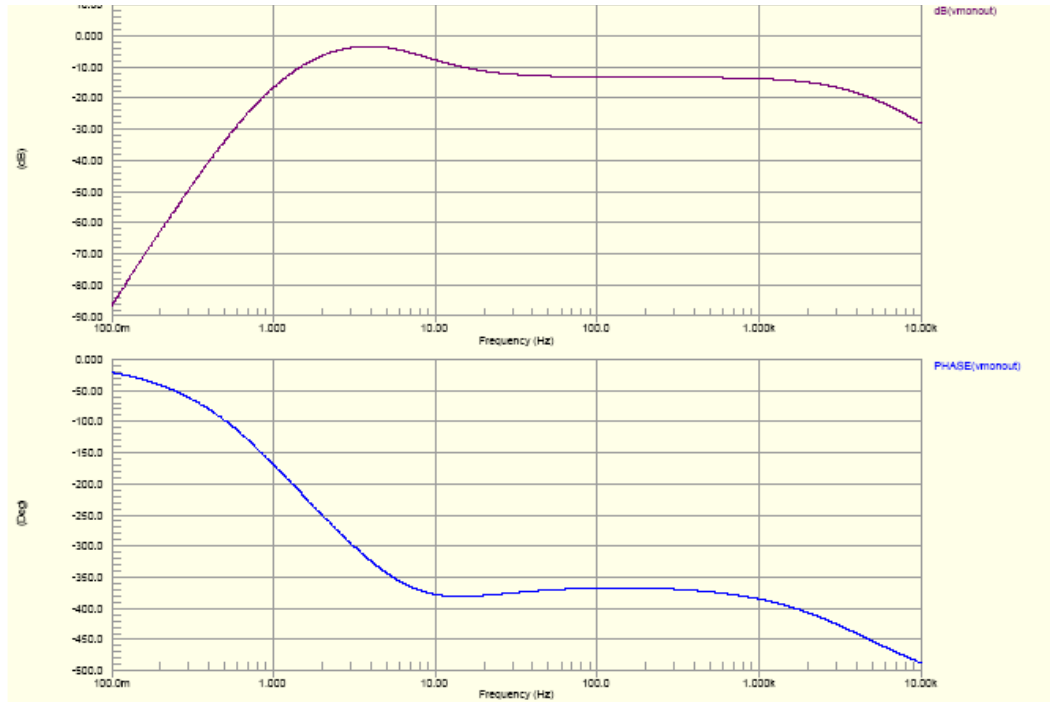

Figure 4: Transfer Function from Input to Noise Monitor Output (Low Noise Mode)

In the tables below, record the measured magnitude and phase of the response for each channel. In addition, save the transfer function for one representative channel to disk and record the file name in space provided below.

Table 13: Channel 1 Noise Monitor Transfer Function Measurements

Freq (Hz)	Nominal Gain (dBV/Volt)	Nominal Phase	Actual Gain (dBV/Volt)	Actual Phase (Degrees)
-----------	-------------------------	---------------	------------------------	------------------------

Serial Number: _____

Date: _____

Tech: _____

		(Degrees)		
0.1	-86.6	-20.9		
1	-16.5	-168.9		
10	-7.7	-377.6		
100	-13.2	-367.3		
1K	-13.7	-385.0		
10K	-28.1	-487.1		

Table 14: Channel 2 Noise Monitor Transfer Function Measurements

Freq (Hz)	Nominal Gain (dBV/Volt)	Nominal Phase (Degrees)	Actual Gain (dBV/Volt)	Actual Phase (Degrees)
0.1	-86.6	-20.9		
1	-16.5	-168.9		
10	-7.7	-377.6		
100	-13.2	-367.3		
1K	-13.7	-385.0		
10K	-28.1	-487.1		

Table 15: Channel 3 Noise Monitor Transfer Function Measurements

Freq (Hz)	Nominal Gain (dBV/Volt)	Nominal Phase (Degrees)	Actual Gain (dBV/Volt)	Actual Phase (Degrees)
0.1	-86.6	-20.9		
1	-16.5	-168.9		
10	-7.7	-377.6		
100	-13.2	-367.3		
1K	-13.7	-385.0		
10K	-28.1	-487.1		

Table 16: Channel 4 Noise Monitor Transfer Function Measurements

Freq (Hz)	Nominal Gain (dBV/Volt)	Nominal Phase (Degrees)	Actual Gain (dBV/Volt)	Actual Phase (Degrees)
0.1	-86.6	-20.9		
1	-16.5	-168.9		
10	-7.7	-377.6		
100	-13.2	-367.3		
1K	-13.7	-385.0		
10K	-28.1	-487.1		

File Name for Noise Monitor Measurement: _____

Channel number for saved file: _____

3.4.2 Noise Monitor Output Noise Tests

The noise monitor circuit has been designed to monitor the output noise voltage of the driver in the lowest noise mode of operation and specifically at 10Hz. The gain of the noise monitor circuit is approximately 42dB and as stated in the driver noise test circuit section above, the output noise of the driver is better than 23.4nV/√Hz at 10Hz. Therefore, the output noise of the monitor circuit must be less than 2.9uV/√Hz at 10Hz when it is connected to the driver and the driver inputs are terminated as in the tests above. In the table below, record the output noise at 10Hz. The inputs to the channel

Serial Number: _____

Date: _____

Tech: _____

under test should be tied to circuit ground and relays K1, K3 and K4 should be energized (Low Noise Mode). In addition, save the noise data for one representative channel to disk and record the file name in space provided below. The frequency range for the saved file should be from 0.1Hz to 100Hz.

Channel Number	Measured Noise at 10Hz
1	
2	
3	
4	

File Name for noise measurement: _____

Channel Number for saved file: _____

3.4.3 Output Voltage and Current Monitor Tests

The monitor board connected to the UIM Driver board inside the chassis provides continuous monitors of the output voltage and current (FC) and rms current (SC) for each channel. These monitors are tested in this section. These tests can be conducted in conjunction with the dynamic range tests described in section 3.1.3 of this document. In the tables below, record the current and voltage monitor output for each input voltage.

Table 17: Channel 1 Monitor Output Tests

Input Voltage	Nominal Voltage Monitor	Nominal Current Monitor (FC)	Nominal rms Current Mon (SC)	Actual Voltage Monitor (Volts)	Actual Current Monitor (Volts)	Actual Current rms Monitor (Volts)
+1V	0.443	0.442	0.442			
-1V	-0.443	-0.442	0.442			
+5V	2.22	2.21	2.21			
-5V	-2.22	-2.21	2.21			
+10V	4.43	4.42	4.42			
-10V	-4.43	-4.42	4.42			
+20V	8.87	8.84	8.84			
-20V	-8.87	-8.84	8.84			

Table 18: Channel 2 Monitor Output Tests

Input Voltage	Nominal Voltage Monitor	Nominal Current Monitor (FC)	Nominal rms Current Mon (SC)	Actual Voltage Monitor (Volts)	Actual Current Monitor (Volts)	Actual Current rms Monitor (Volts)
+1V	0.443	0.442	0.442			
-1V	-0.443	-0.442	0.442			
+5V	2.22	2.21	2.21			
-5V	-2.22	-2.21	2.21			
+10V	4.43	4.42	4.42			
-10V	-4.43	-4.42	4.42			
+20V	8.87	8.84	8.84			
-20V	-8.87	-8.84	8.84			

Serial Number: _____

Date: _____

Tech: _____

Table 19: Channel 3 Monitor Output Tests

Input Voltage	Nominal Voltage Monitor	Nominal Current Monitor (FC)	Nominal rms Current Mon (SC)	Actual Voltage Monitor (Volts)	Actual Current Monitor (Volts)	Actual Current rms Monitor (Volts)
+1V	0.443	0.442	0.442			
-1V	-0.443	-0.442	0.442			
+5V	2.22	2.21	2.21			
-5V	-2.22	-2.21	2.21			
+10V	4.43	4.42	4.42			
-10V	-4.43	-4.42	4.42			
+20V	8.87	8.84	8.84			
-20V	-8.87	-8.84	8.84			

Table 20: Channel 4 Monitor Output Tests

Input Voltage	Nominal Voltage Monitor	Nominal Current Monitor (FC)	Nominal rms Current Mon (SC)	Actual Voltage Monitor (Volts)	Actual Current Monitor (Volts)	Actual Current rms Monitor (Volts)
+1V	0.443	0.442	0.442			
-1V	-0.443	-0.442	0.442			
+5V	2.22	2.21	2.21			
-5V	-2.22	-2.21	2.21			
+10V	4.43	4.42	4.42			
-10V	-4.43	-4.42	4.42			
+20V	8.87	8.84	8.84			
-20V	-8.87	-8.84	8.84			