

REV	DATE	APPROVAL	DESCRIPTION
00	10/27/2008	A. STEIN	PROTOTYPE RELEASE.

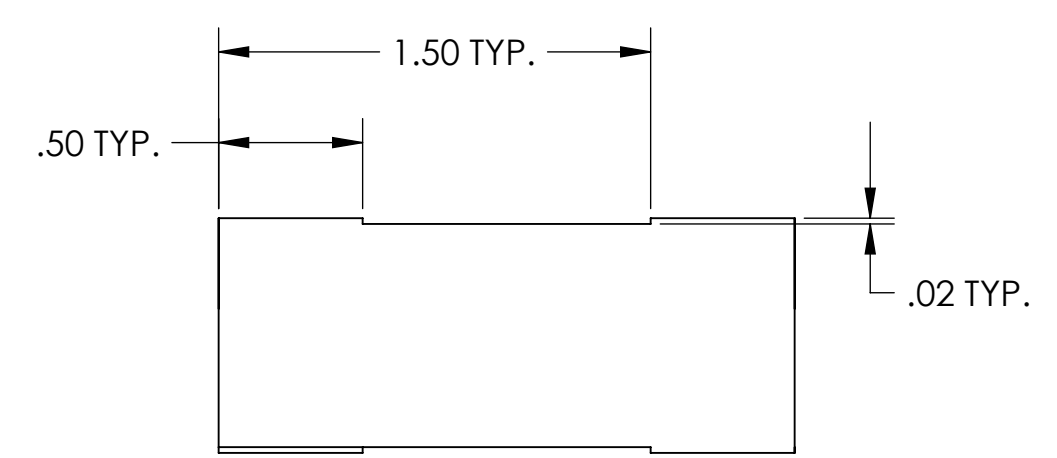
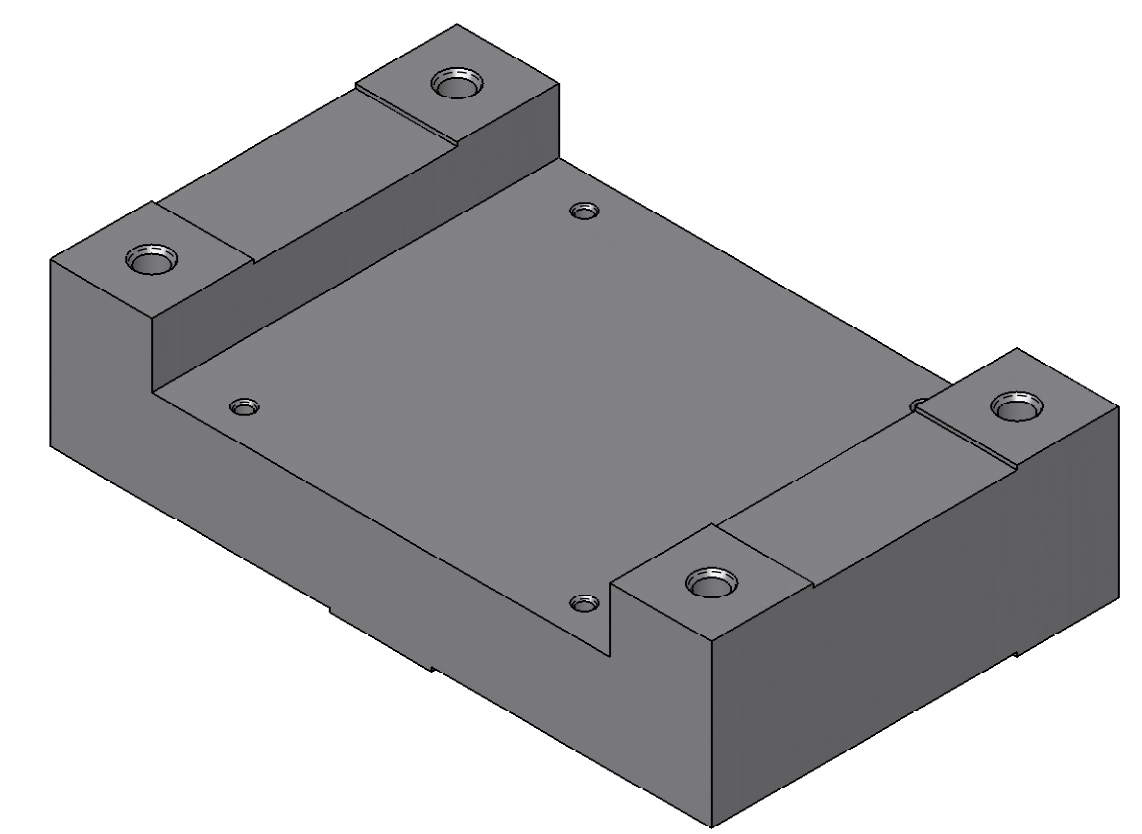
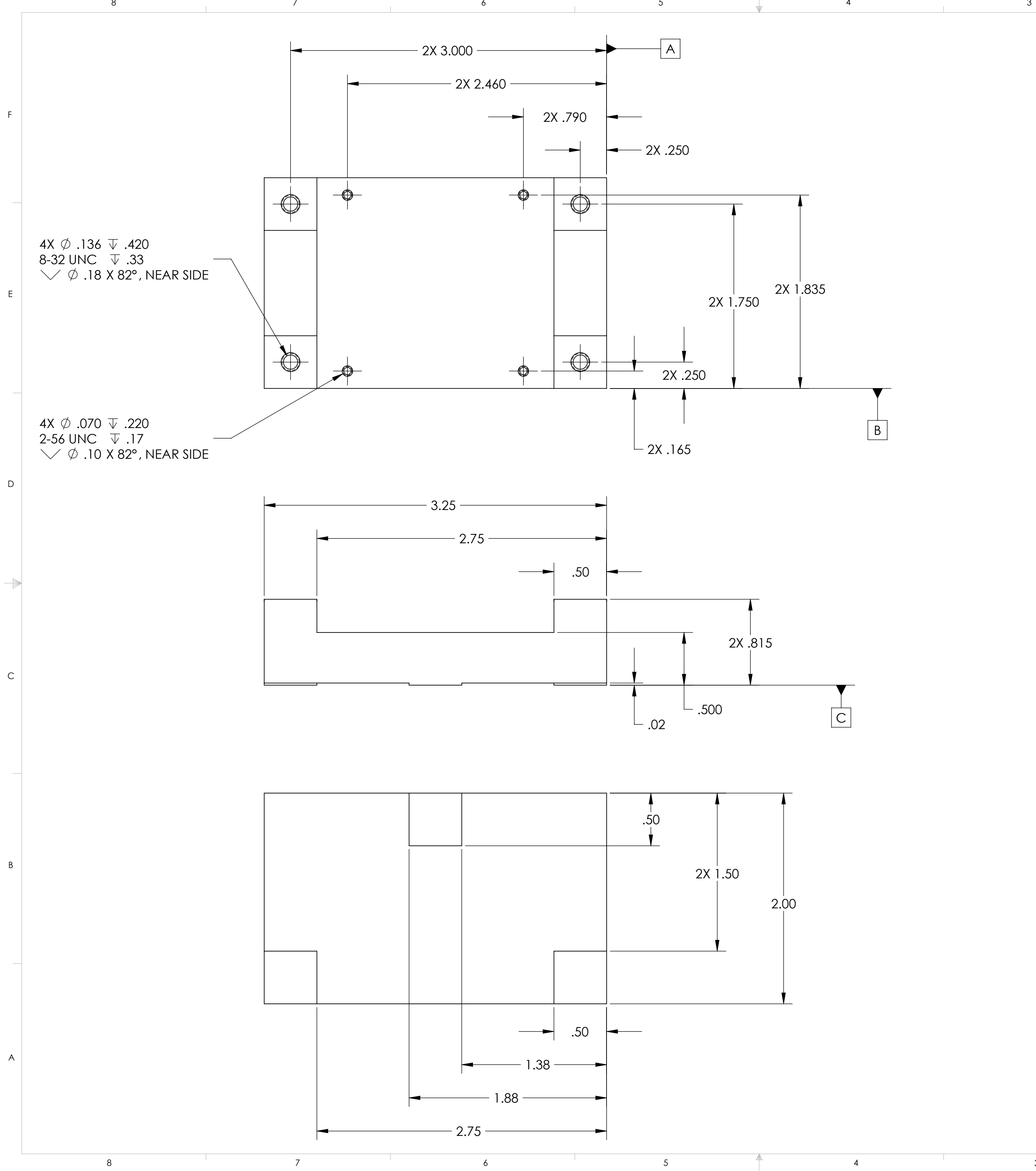

NOTES: (UNLESS OTHERWISE SPECIFIED)

- DO NOT SCALE FROM DRAWING.
- REMOVE ALL SHARP EDGES. LEAVE .005 X 45° MIN CHAMFER, OR .005 MIN RADIUS.
- ALL MACHINING FLUIDS MUST BE WATER SOLUBLE AND FREE OF SULFUR, CHLORINE AND SILICONE. E.G. MILACRON CIMTECH 410.
- CLEAN THOROUGHLY TO REMOVE ALL OIL, DIRT, AND CHIPS.

DIMENSIONS ARE IN INCHES

TOLERANCES:
 XX ± 0.015
 XXX ± 0.005

ANGULAR ± 0.5°

MATERIAL 6061-T6

FINISH NONE

DRAWN A. STEIN 10/27/2008

CHECKED

APPROVED

LIGO CALIFORNIA INSTITUTE OF TECHNOLOGY
 MASSACHUSETTS INSTITUTE OF TECHNOLOGY
 IGR, GLASGOW UNIVERSITY GEO 600 GROUP

SYSTEM ADVANCED LIGO

SUB-SYSTEM SEI

NEXT ASSY D080676

PART NAME ADE SENSOR MOUNT

SIZE C **DWG. NO.** D080674 **REV.** 00

SCALE: 3:2 **PROJECTION:** **SHEET 1 OF 1**