

REV.	DATE	DCN #	DRAWING TREE #
v1	11th Nov 2008	LIGO-E080530-v1	
v2	Feb - 20 - 2009	LIGO-E0900044-v1	
v3	Mar-26-2009	LIGO-E0900095-v1	
v4	28 MAY 2010	E1000188	
v5	06 DEC 2019	E1900200-v3	

SUBSTRATE IS SHOWN IN SUSPENDED STATE WITH VERTICAL WEDGE (THICK SIDE DOWN). THE ARROWED LINE IS SHOWN ON THE THIN SIDE, AND AS STATED POINTS TO SURFACE 'S1'.

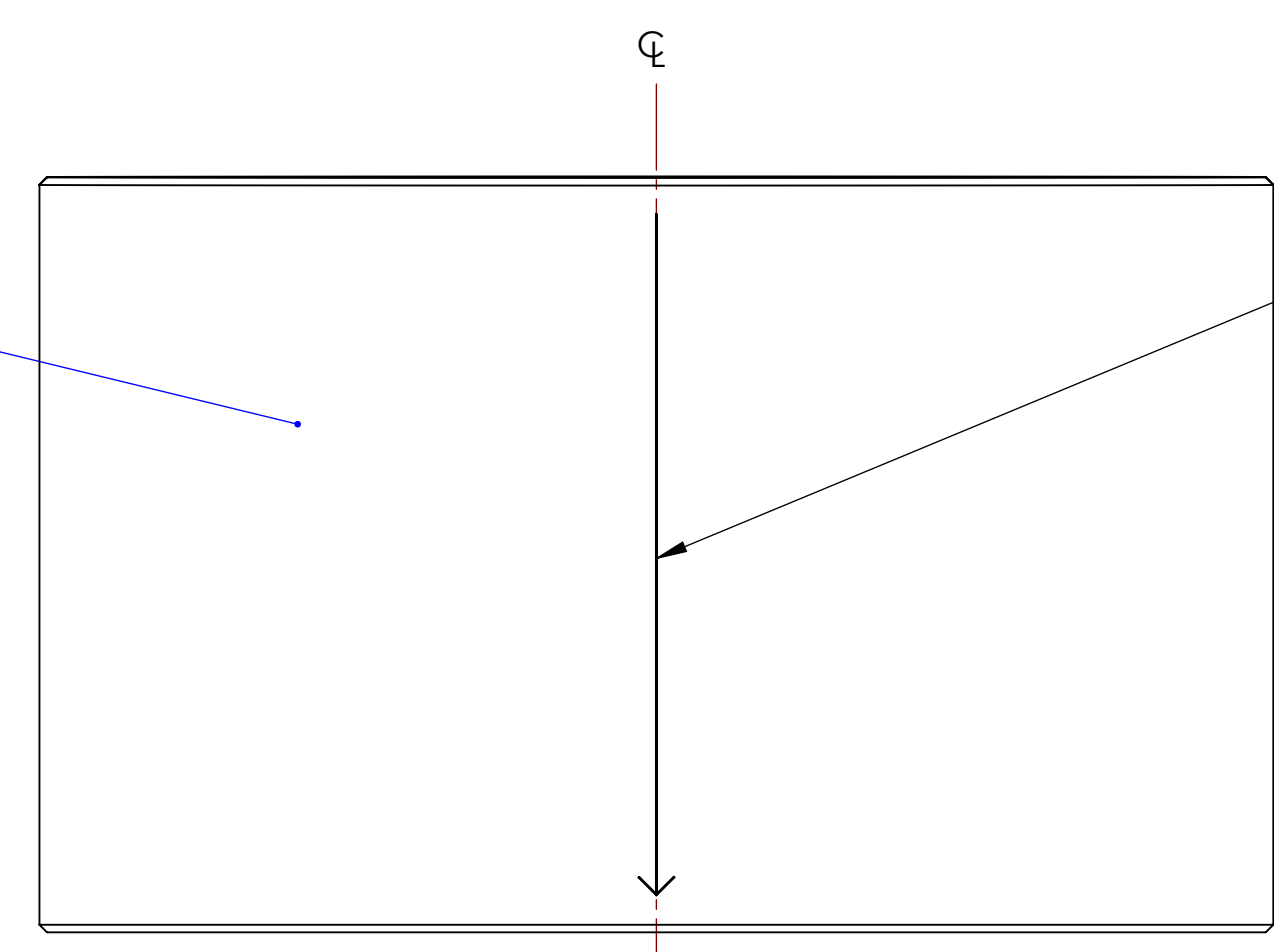
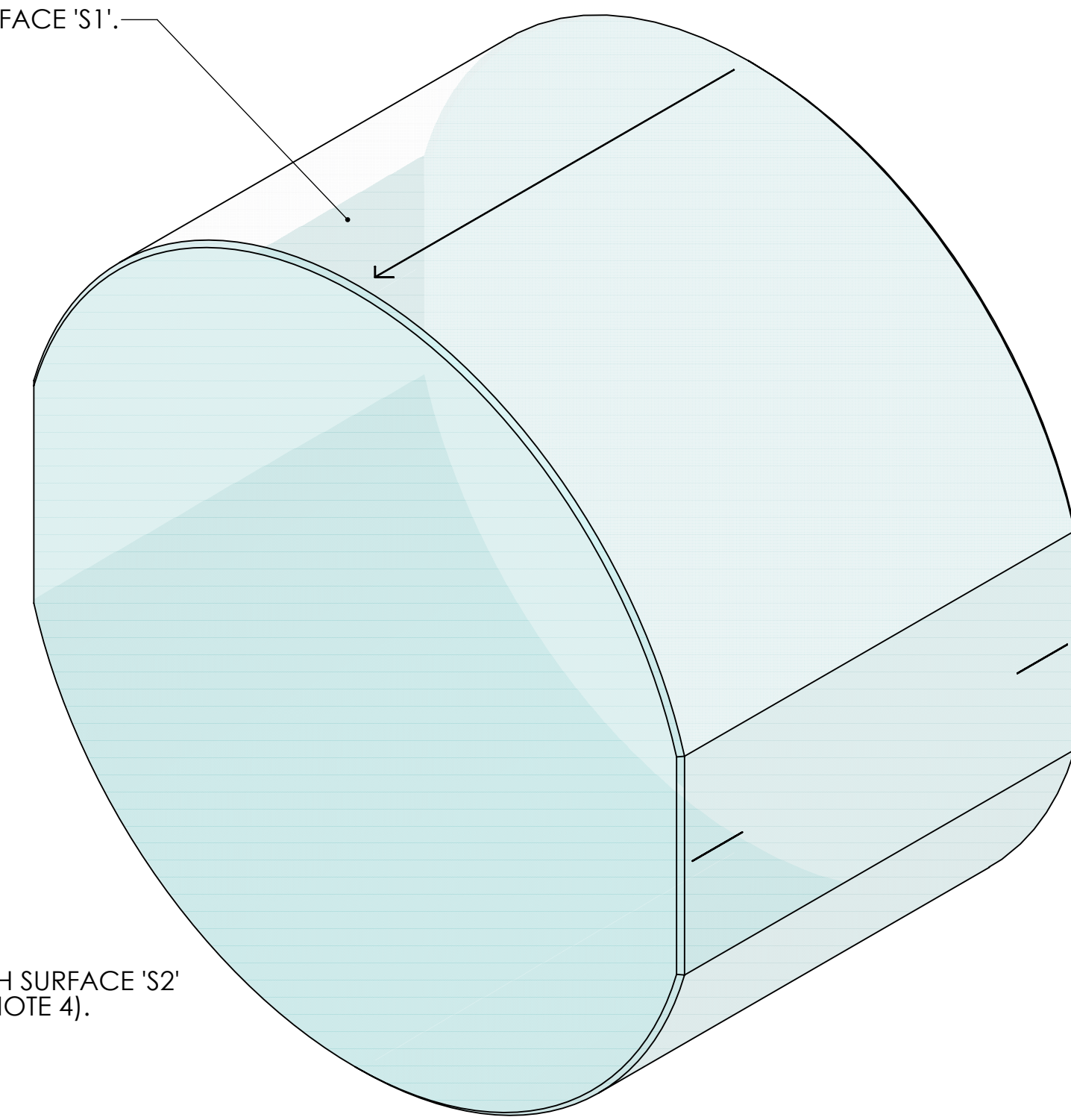

TOP VIEW

ETCH OR GRIND LEGIBLE REFERENCE GROOVE (0.25mm ± 0.05mm WIDE) ALONG ϕ WITHIN ±1° CLOCKING ANGLE (WITH RESPECT TO DATUM FEATURE -A-), PARALLEL TO THE CYLINDRICAL AXIS (DEFINED BY DATUM FEATURE -A-), WITH ARROW POINTING TO SURFACE 'S1' WITHIN ±0.1mm

BARREL (SIDE) AND BEVEL POLISH (SEE NOTE 3)

0.6 C (REFER TO NOTE 8.)

2X, 29.0 ± 0.5 ON BOTH FLATS

2X, 6.0

Ø 340.00 ± 0.25
0.1
0.25 C

S6 POLISH SURFACE 'S6' (SEE NOTE 3).

POLISH SURFACE 'S1' (SEE NOTE 4).

S2 POLISH SURFACE 'S2' (SEE NOTE 4).

ETCH OR GRIND SERIAL NUMBER, APPROX. WHERE SHOWN, LETTERING APPROX. 4mm HIGH (SEE NOTE 7 FOR FURTHER DETAILS)

POLISH CROSS HATCHED AREA SEE NOTE 6 (REPEAT ON SURFACE 'S3').

POLISH SURFACE 'S4' SEE NOTE 5 (REPEAT ON SURFACE 'S3')

4X, R5 TYP

2X, 2.0 ± 0.2 x 45° ± 5° CHAMFER, ALL AROUND

10.0
32.5
65.0

S5 POLISH SURFACE 'S5' (SEE NOTE 3).

(2.0)

200.0^{+0.5}_{-1.0}

(2X, 95 TYP)

90.0°

0.25 C

0.25 B
0.25 C

326.5^{+0.0}_{-0.6}
0.2 A

BARREL (SIDE) AND BEVEL POLISH (SEE NOTE 3)

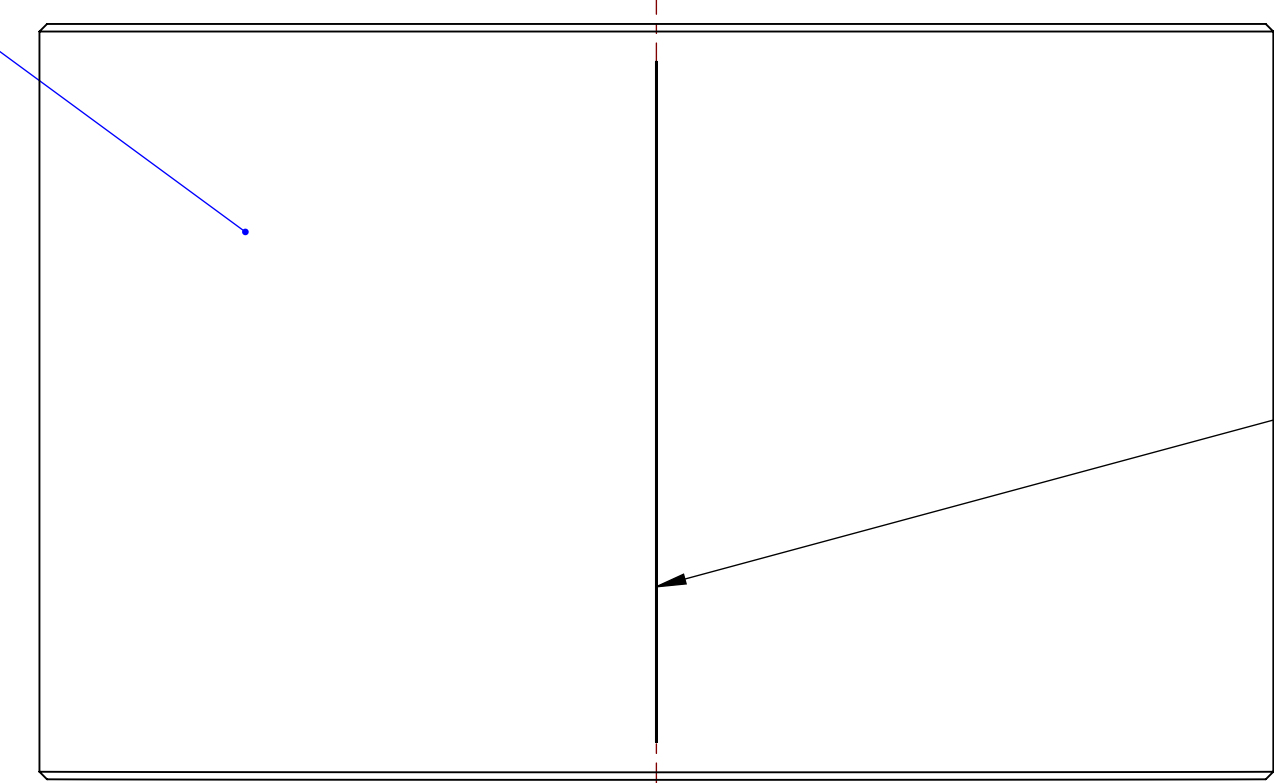

BOTTOM VIEW

ETCH OR GRIND LEGIBLE REFERENCE GROOVE (0.25mm ± 0.05mm WIDE) ALONG ϕ WITHIN ±1° CLOCKING ANGLE (WITH RESPECT TO DATUM FEATURE -A-), PARALLEL TO THE CYLINDRICAL AXIS (DEFINED BY DATUM FEATURE -A-), WITHIN ±0.1mm

2X, ETCH OR GRIND LEGIBLE REFERENCE GROOVE (WIDTH 0.25mm ± 0.05mm) ALONG ϕ , PARALLEL TO THE CYLINDRICAL AXIS (DEFINED BY DATUM FEATURE -A-), REPEAT ON SURFACE 'S4' WITHIN ±0.1mm

.07°^{+0.03}_{-0.00}
WEDGE ANGLE

MANUFACTURE NOTES:

- DO NOT SCALE FROM DRAWING.
- INTERPRET DRAWING AS PER ANSI Y14.5M 1994.
- BARREL (SIDE) AND BEVEL POLISH PER E080512.
- FINISH SURFACES 'S1' AND 'S2' AS PER E080512.
- FINISH (FLAT) SURFACES 'S3' AND 'S4' AS PER E080512.
- FINISH CROSS HATCHED AREA ON 'S3' & 'S4' AS PER E080512.
- REFER TO E080512 FOR MORE INFORMATION ON SERIAL NUMBER.
- INTENDED TO CAPTURE ALLOWABLE WEDGE ANGLE CLOCKING TOLERANCE OF ±5°.
- APPLY COATING PER E0900068.

PARTS LIST

DIMENSIONS ARE IN MILLIMETERS		LIGO CALIFORNIA INSTITUTE OF TECHNOLOGY MASSACHUSETTS INSTITUTE OF TECHNOLOGY	
TOLERANCES:		SYSTEM	ADVANCED LIGO
X ± 0.1		SUB-SYSTEM	COC
XX ± 0.05		NEXT ASSY	ETM
ANGULAR ± 0.1°			
MATERIAL:	REF E080047-v1	PART NAME	ETM SUBSTRATE

NAME	DATE	SIZE	DWG. NO.	REV.	
DRAWN	C. TORRE	14 Nov 08	D	D080658	v5
CHECKED	D. COYNE	19 Nov 08			
CHECKED	F. GOSWAMI	18 Nov 08			
APPROVED	D. COYNE	17 Dec 08			