

REV.	DATE	DCN #	DRAWING TREE #
v1	11th Nov 2008	LIGO-E080530-v1	

SUBSTRATE IS SHOWN IN SUSPENDED STATE WITH VERTICAL WEDGE (THICK SIDE DOWN). THE ARROWED LINE IS SHOWN ON THE THIN SIDE, AND AS STATED POINTS TO SURFACE 'S1'.

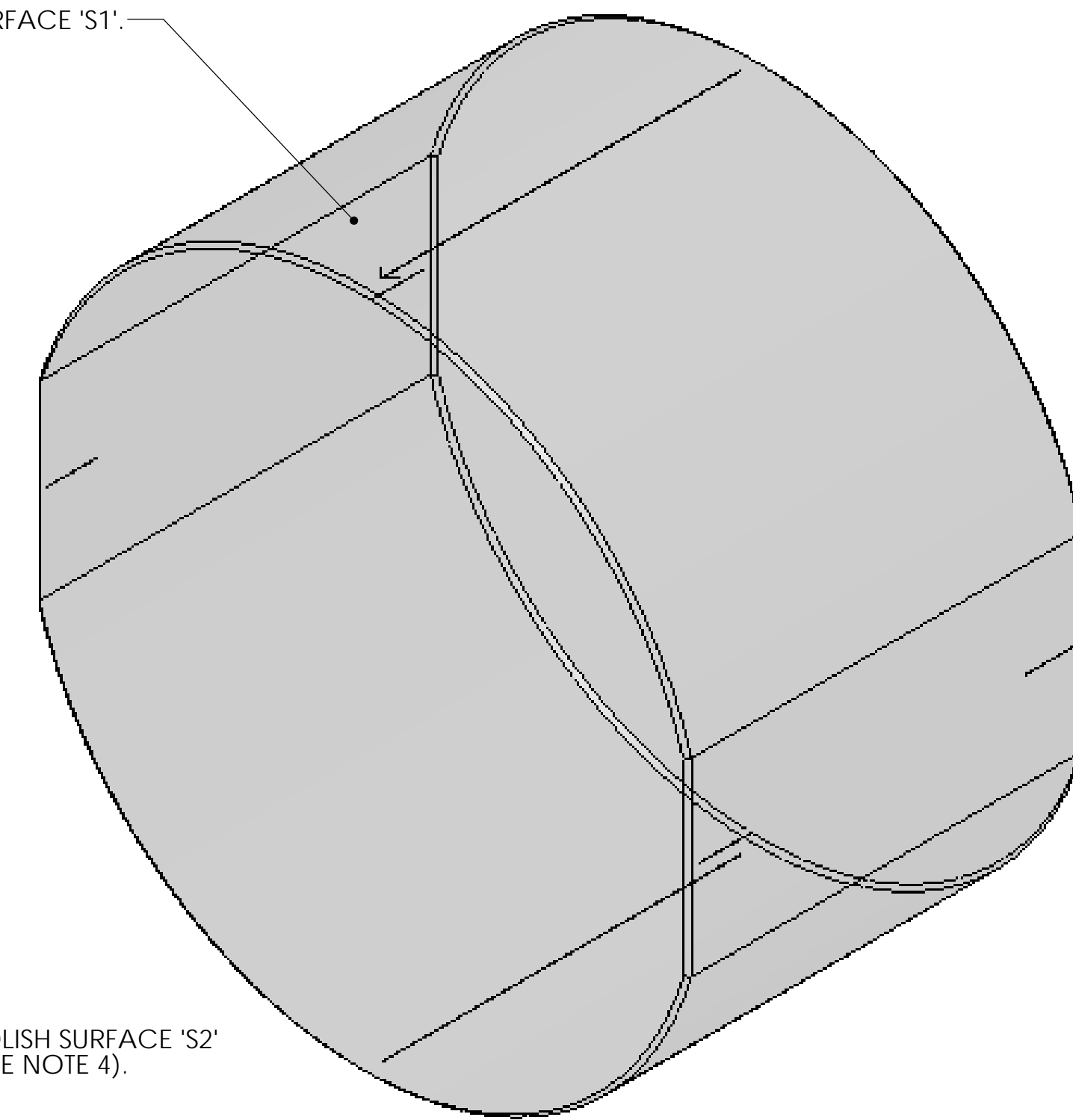

BARREL (SIDE) AND BEVEL POLISH (SEE NOTE 3)

ETCH OR GRIND LEGIBLE REFERENCE GROOVE (0.25mm ± 0.05mm WIDE) ALONG ϕ WITHIN ±1° CLOCKING ANGLE (WITH RESPECT TO DATUM FEATURE -A-), PARALLEL TO THE CYLINDRICAL AXIS (DEFINED BY DATUM FEATURE -A-) WITH ARROW POINTING TO SURFACE 'S1' WITHIN ±0.1mm

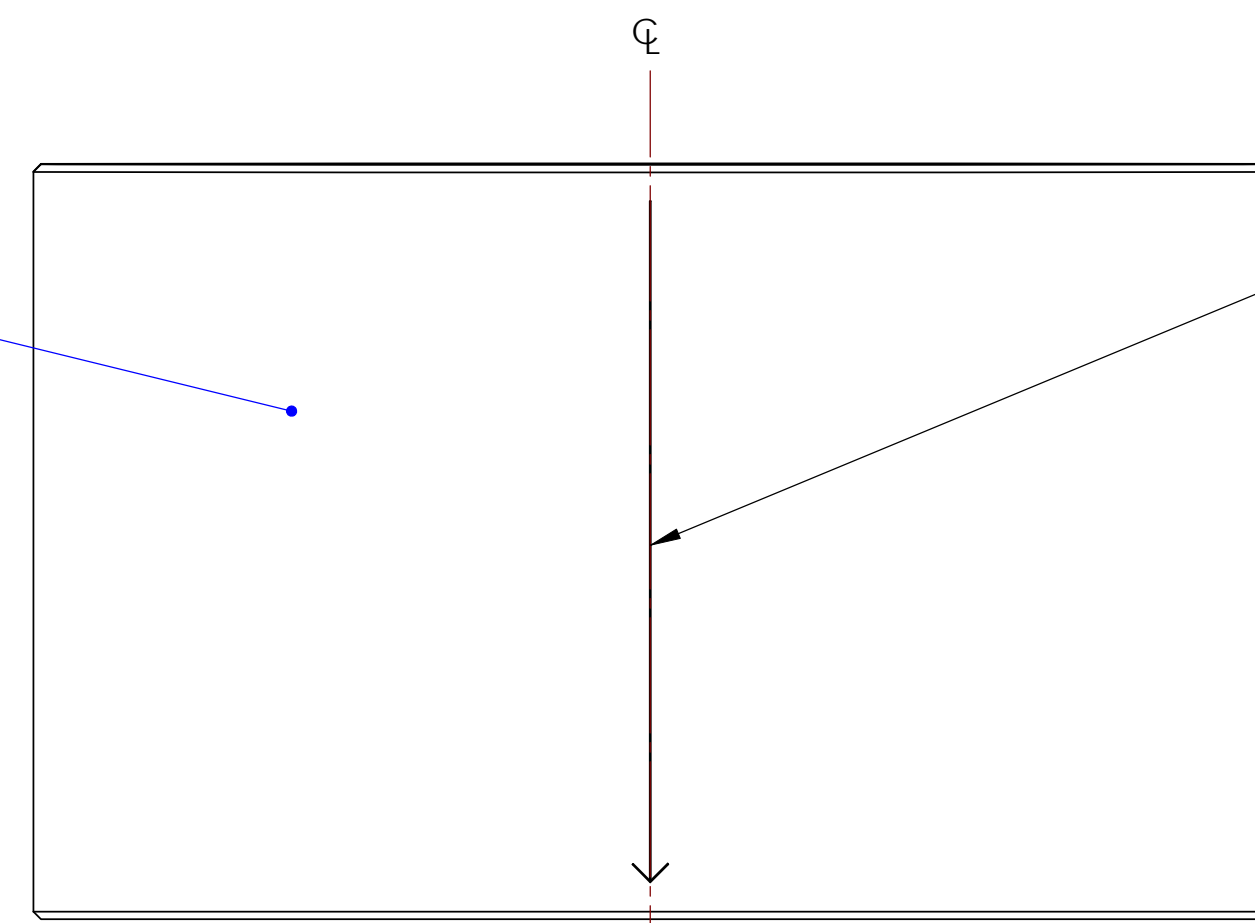

TOP VIEW

0.6 C (REFER TO NOTE 8.)

2X, 29.0 ± 0.5 ON BOTH FLATS

2X, 6.0

Ø 340.00 ± 0.25
0.1
0.25 C

S6 POLISH SURFACE 'S6' (SEE NOTE 3).

POLISH SURFACE 'S1' (SEE NOTE 4).

S2 POLISH SURFACE 'S2' (SEE NOTE 4).

(2X, 95 TYP)

90.0°

0.25 C

0.25 B
0.25 C

POLISH CROSS HATCHED AREA SEE NOTE 6 (REPEAT ON SURFACE 'S3').

POLISH SURFACE 'S4' SEE NOTE 5 (REPEAT ON SURFACE 'S3').

4X, R5 TYP

S5 POLISH SURFACE 'S5' (SEE NOTE 3).

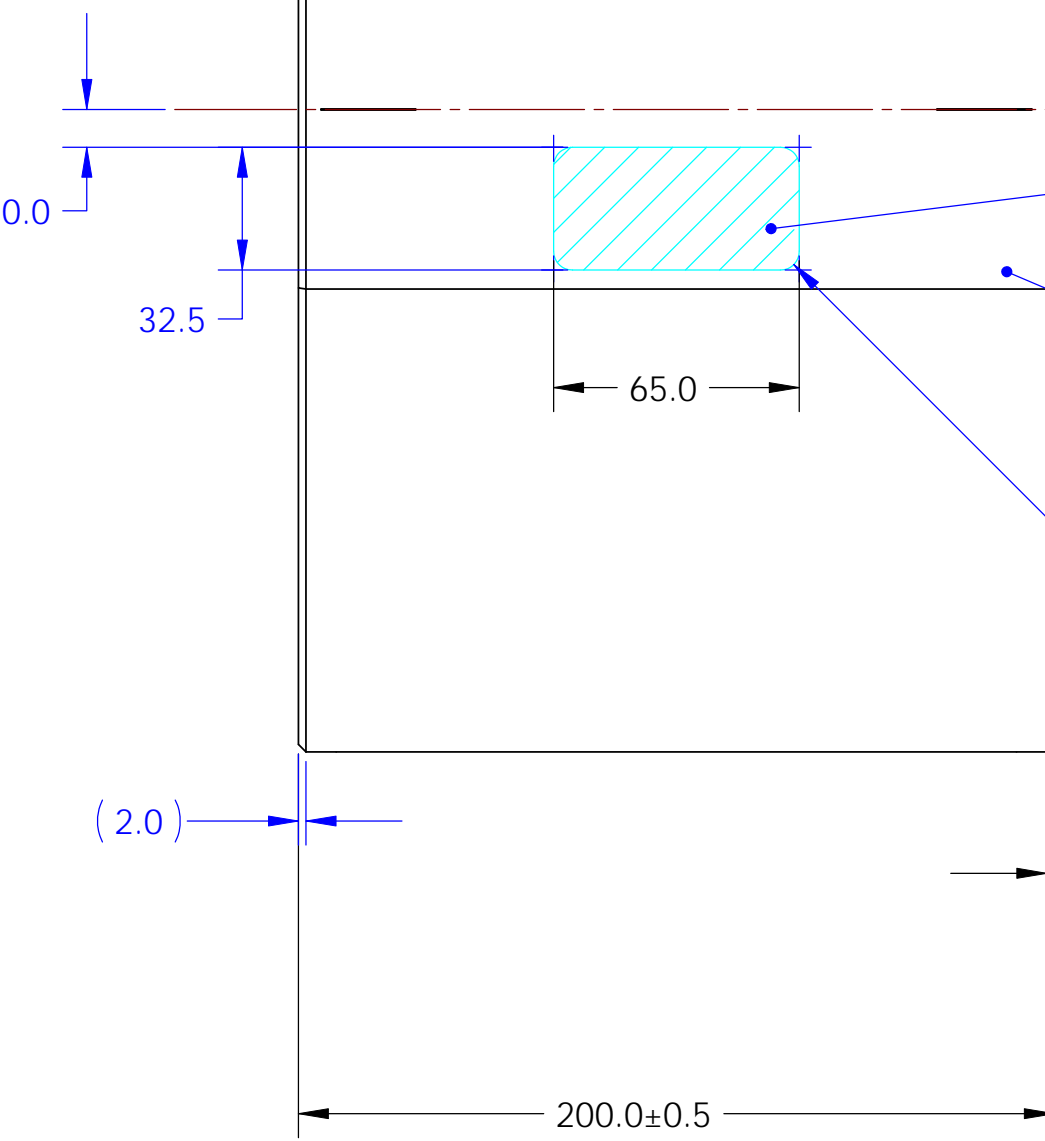

0.07° +0.03° -0.00°
WEDGE ANGLE

BARREL (SIDE) AND BEVEL POLISH (SEE NOTE 3)

2X, ETCH OR GRIND LEGIBLE REFERENCE GROOVE (WIDTH 0.25mm ± 0.05mm) ALONG ϕ , PARALLEL TO THE CYLINDRICAL AXIS (DEFINED BY DATUM FEATURE -A-). REPEAT ON SURFACE 'S4' WITHIN ±0.1mm

ETCH OR GRIND LEGIBLE REFERENCE GROOVE (0.25mm ± 0.05mm WIDE) ALONG ϕ WITHIN ±1° CLOCKING ANGLE (WITH RESPECT TO DATUM FEATURE -A-), PARALLEL TO THE CYLINDRICAL AXIS (DEFINED BY DATUM FEATURE -A-) WITHIN ±0.1mm

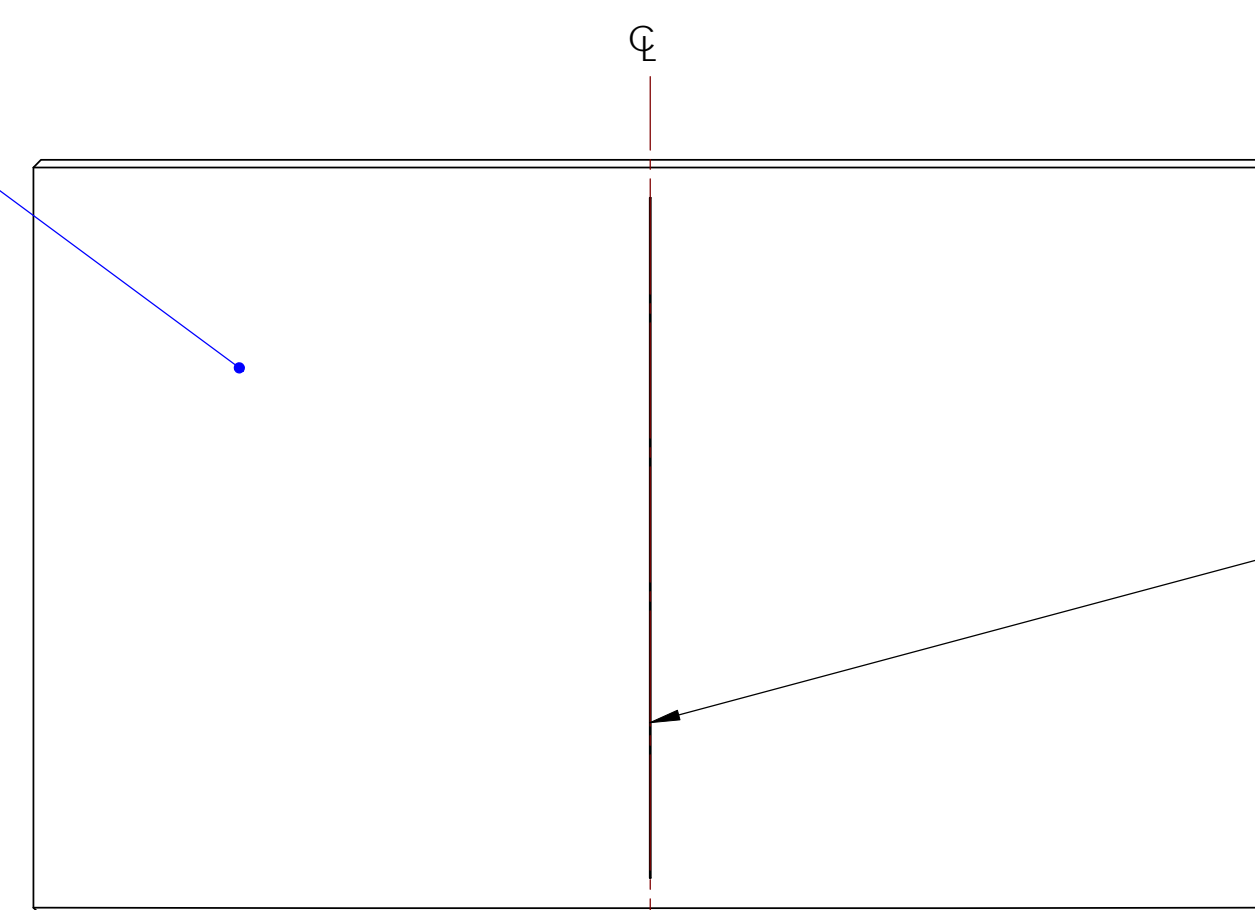

BOTTOM VIEW

326.5 ± 0.2
0.2 A

2X, 2.0 ± 0.2 x 45° ± 5° CHAMFER, ALL AROUND

(2.0)

200.0 ± 0.5

MANUFACTURE NOTES:			
1.	DO NOT SCALE FROM DRAWING.		
2.	INTERPRET DRAWING AS PER ANSI Y14.5M 1994.		
3.	BARREL (SIDE) AND BEVEL POLISH PER E080512-v1.		
4.	FINISH SURFACES 'S1' AND 'S2' AS PER E080512-v1.		
5.	FINISH (FLAT) SURFACES 'S3' AND 'S4' AS PER E080512-v1.		
6.	FINISH CROSS HATCHED AREA ON 'S3' & 'S4' AS PER E080512-v1.		
7.	REFER TO E080512-v1 FOR MORE INFORMATION ON SERIAL NUMBER.		
8.	INTENDED TO CAPTURE ALLOWABLE WEDGE ANGLE CLOCKING TOLERANCE OF ±5°.		

PARTS LIST	
NOTES (UNLESS OTHERWISE SPECIFIED):	
DIMENSIONS ARE IN MILLIMETERS	
TOLERANCES:	
X ± 0.1	
XX ± 0.05	
ANGULAR ± 0.1°	
MATERIAL:	REF E080047-v1
FINISH:	SEE NOTES
DRAWN:	C. TORRE 14 Nov 08
CHECKED:	D. COVINE 10 Nov 08
APPROVED:	D. COVINE 17 Dec 08
SCALE:	1:2
PROJECTION:	1
PART NAME:	ETM SUBSTRATE
DWG. NO.:	D080658
SHEET:	1 OF 1