

REV.	DATE	DCN #	DRAWING TREE #
v1	11th Nov 2008	LIGO-E080530-v1	

BARREL (SIDE) AND BEVEL POLISH (SEE NOTE 3)

ETCH OR GRIND LEGIBLE REFERENCE GROOVE (0.25mm ± 0.05mm WIDE) ALONG ϕ WITHIN ±1° CLOCKING ANGLE (WITH RESPECT TO DATUM FEATURE -A-), PARALLEL TO THE CYLINDRICAL AXIS (DEFINED BY DATUM FEATURE -A-) WITH ARROW POINTING TO SURFACE 'S1' WITHIN ±0.1mm

SUBSTRATE IS SHOWN IN SUSPENDED STATE WITH VERTICAL WEDGE (THICK SIDE DOWN). THE ARROWED LINE IS SHOWN ON THE THIN SIDE, AND AS STATED POINTS TO SURFACE 'S1'.

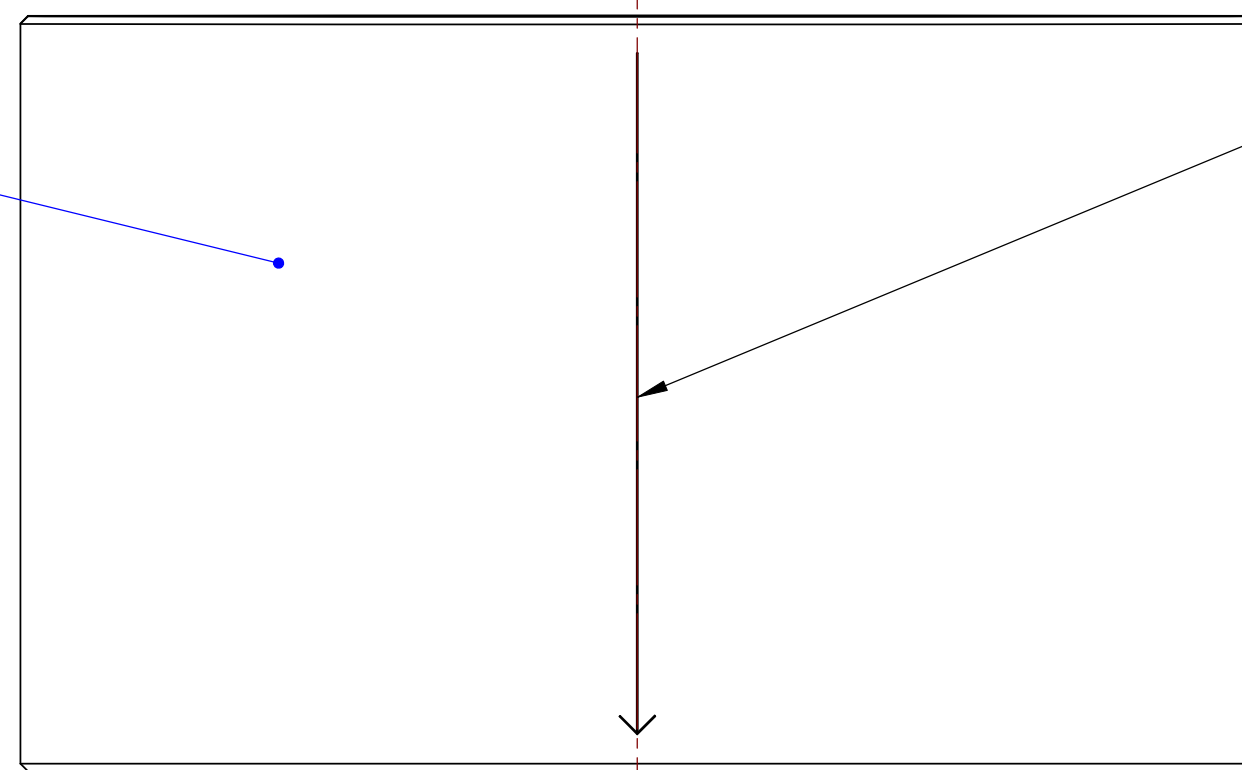
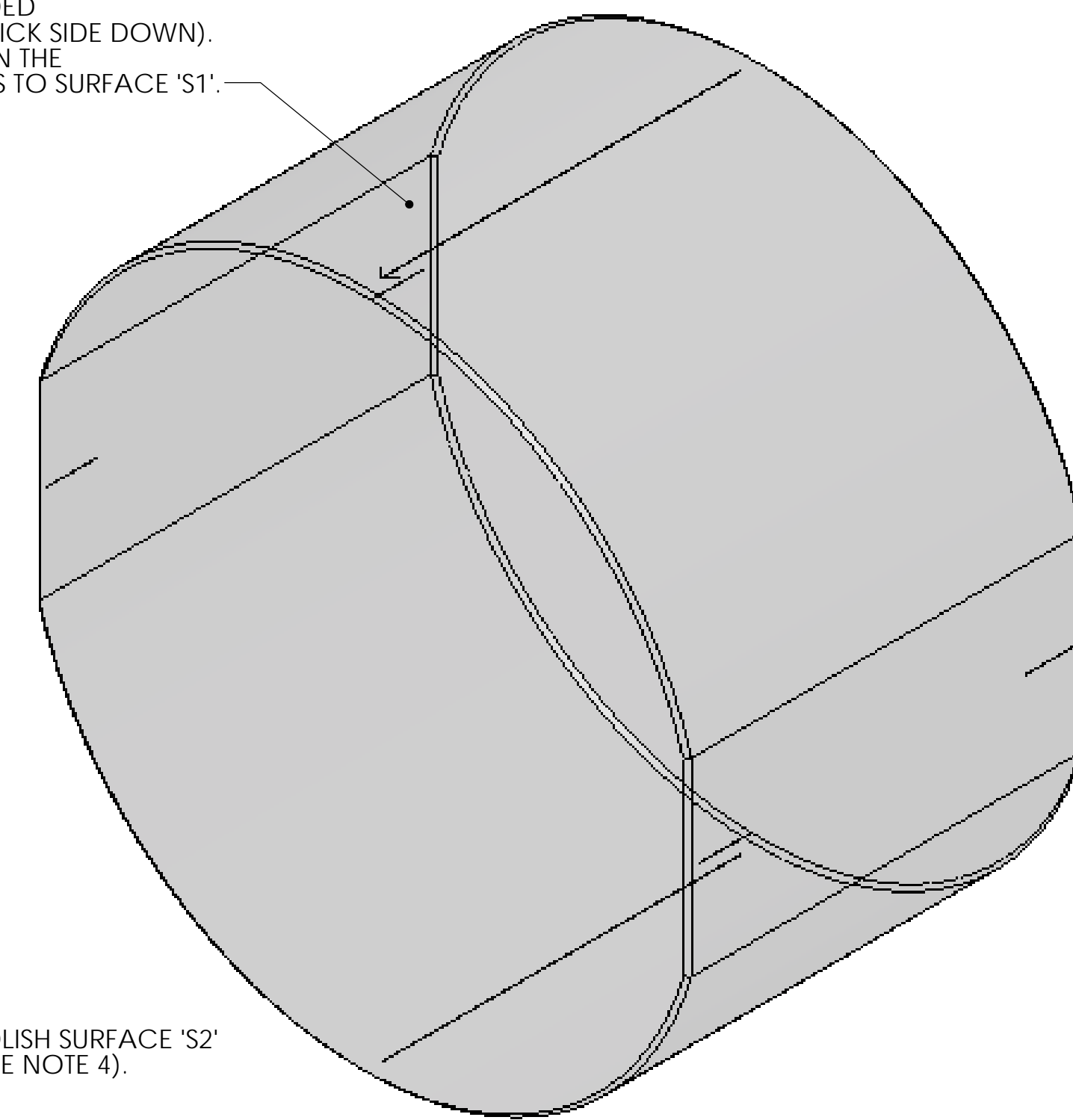

TOP VIEW

≤ 0.6 C (REFER TO NOTE 8.)

2X, 29.0±0.5 ON BOTH FLATS

2X, 6.0

$\phi 340.00 \pm 0.25$
 ≤ 0.1
 ≤ 0.25 C

≤ 0.25 B
 ≤ 0.25 C

POLISH SURFACE 'S1' (SEE NOTE 4).

≤ 0.25 B
 ≤ 0.25 C

POLISH SURFACE 'S5' (SEE NOTE 3).

POLISH SURFACE 'S2' (SEE NOTE 4).

ETCH OR GRIND SERIAL NUMBER, APPROX. WHERE SHOWN, LETTERING APPROX. 4mm HIGH (SEE NOTE 7 FOR FURTHER DETAILS)

POLISH CROSS HATCHED AREA SEE NOTE 6 (REPEAT ON SURFACE 'S3').

POLISH SURFACE 'S4' SEE NOTE 5 (REPEAT ON SURFACE 'S3').

4X, R5 TYP

2X, ± 0.2 x 45° ± 5° CHAMFER, ALL AROUND

(2X, 95 TYP)

90.0°

≤ 0.25 C

S1

S3

≤ 0.25 B
 ≤ 0.25 C

10.0

32.5

65.0

(2.0)

200.0±0.5

0.7° +0.03°
 -0.00°
 WEDGE ANGLE

BARREL (SIDE) AND BEVEL POLISH (SEE NOTE 3)

2X, ETCH OR GRIND LEGIBLE REFERENCE GROOVE (WIDTH 0.25mm ± 0.05mm) ALONG ϕ , PARALLEL TO THE CYLINDRICAL AXIS (DEFINED BY DATUM FEATURE -A-). REPEAT ON SURFACE 'S4' WITHIN ±0.1mm

ETCH OR GRIND LEGIBLE REFERENCE GROOVE (0.25mm ± 0.05mm WIDE) ALONG ϕ WITHIN ±1° CLOCKING ANGLE (WITH RESPECT TO DATUM FEATURE -A-), PARALLEL TO THE CYLINDRICAL AXIS (DEFINED BY DATUM FEATURE -A-) WITHIN ±0.1mm

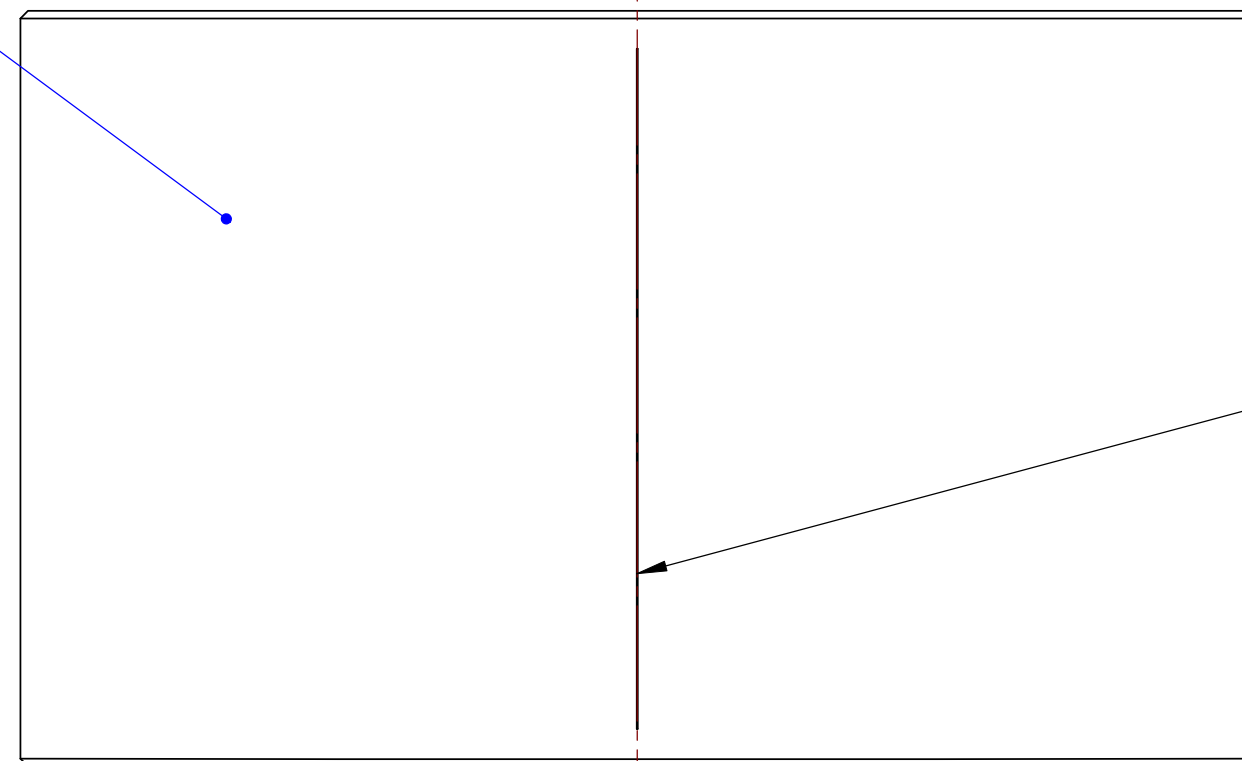

BOTTOM VIEW

MANUFACTURE NOTES:	
1. DO NOT SCALE FROM DRAWING.	
2. INTERPRET DRAWING AS PER ANSI Y14.5M 1994.	
3. BARREL (SIDE) AND BEVEL POLISH PER E080511-v1.	
4. FINISH SURFACES 'S1' AND 'S2' AS PER E080511-v1.	
5. FINISH (FLAT) SURFACES 'S3' AND 'S4' AS PER E080511-v1.	
6. FINISH CROSS HATCHED AREA ON 'S3' & 'S4' AS PER E080511-v1.	
7. REFER TO E080511-v1 FOR MORE INFORMATION ON SERIAL NUMBER.	
8. INTENDED TO CAPTURE ALLOWABLE WEDGE ANGLE CLOCKING TOLERANCE OF ±5°.	

PARTS LIST	
NOTES (UNLESS OTHERWISE SPECIFIED):	
DIMENSIONS ARE IN MILLIMETERS	
TOLERANCES:	
X ± 0.1	
XX ± 0.05	
ANGULAR ± 0.1°	
MATERIAL:	REF E080031-v1
FINISH:	SEE NOTES
NAME:	ITM SUBSTRATE
DATE:	
CHECKED:	D
APPROVED:	

NAME	DATE	SIZE	DWG. NO.	REV.
DRAWN		D	D080657	v1
CHECKED				
CHECKED				
APPROVED				

SCALE: 1:2 PROJECTION: 1st ANGLE SHEET 1 OF 1