

REVISIONS				
ZONE	REV.	DESCRIPTION	DATE	APPROVED
-	-	version 4	3.17.2010	LDI

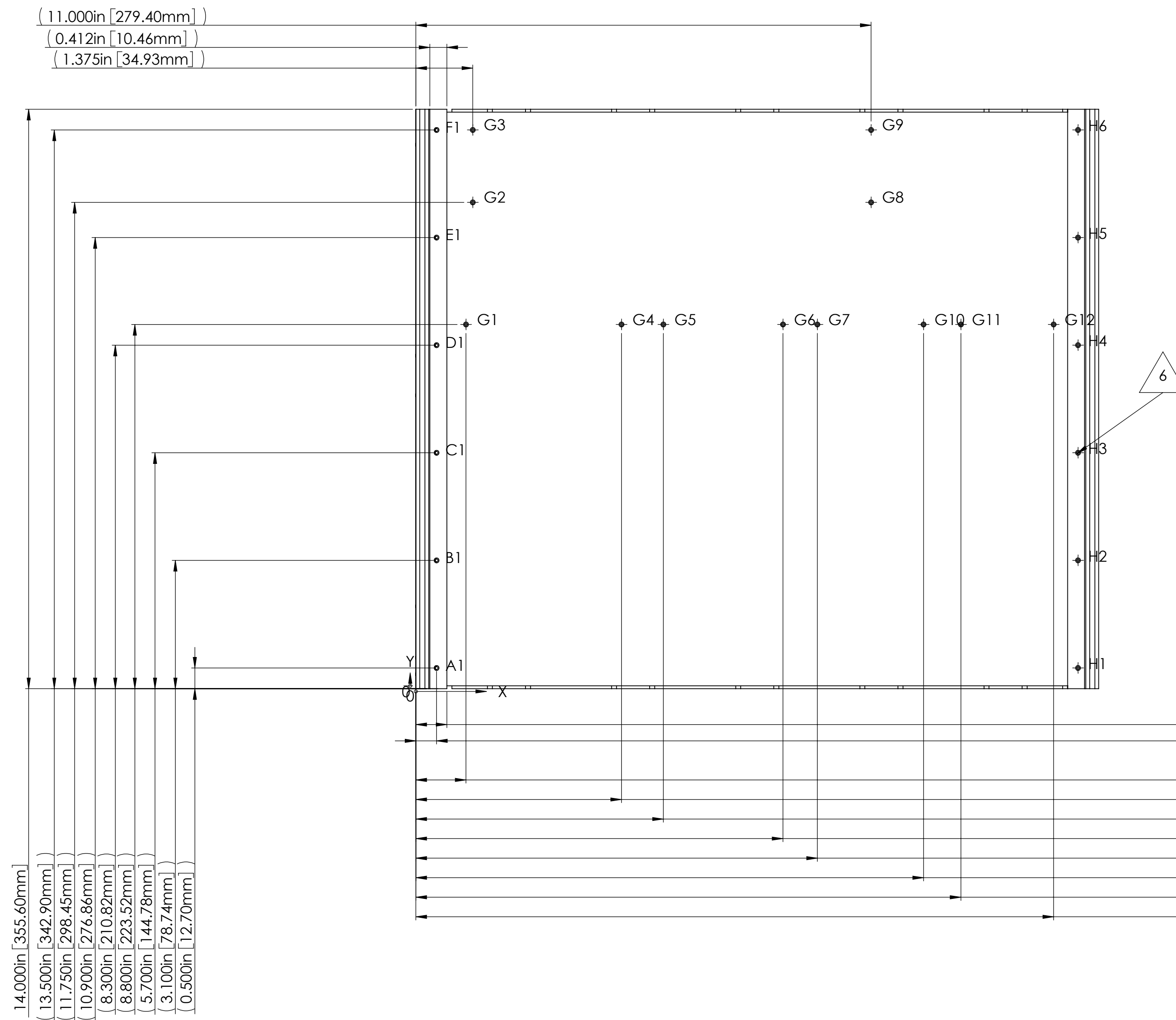

(0.750in [19.05mm])
(0.500in [12.70mm])
(1.211in [30.76mm])
(4.969in [126.21mm])
(5.980in [151.90mm])
(8.871in [225.32mm])
(9.702in [246.43mm])
(12.267in [311.59mm])
(13.171in [334.54mm])
(15.411in [391.44mm])

TAG	X LOC	Y LOC	SIZE
A1	0.50	0.43	
B1	0.50	3.03	
C1	0.50	5.63	
D1	0.50	8.23	
E1	0.50	10.83	
F1	0.50	13.43	
G1	1.21	8.73	Ø 0.07 THRU ALL Ø 0.12 X 100°
G2	1.38	11.68	Ø 0.07 THRU ALL Ø 0.12 X 100°
G3	1.38	13.43	Ø 0.07 THRU ALL Ø 0.12 X 100°
G4	4.97	8.73	Ø 0.07 THRU ALL Ø 0.12 X 100°
G5	5.98	8.73	Ø 0.07 THRU ALL Ø 0.12 X 100°
G6	8.87	8.73	Ø 0.07 THRU ALL Ø 0.12 X 100°
G7	9.70	8.73	Ø 0.07 THRU ALL Ø 0.12 X 100°
G8	11.00	11.68	Ø 0.07 THRU ALL Ø 0.12 X 100°
G9	11.00	13.43	Ø 0.07 THRU ALL Ø 0.12 X 100°
G10	12.27	8.73	Ø 0.07 THRU ALL Ø 0.12 X 100°
G11	13.17	8.73	Ø 0.07 THRU ALL Ø 0.12 X 100°
G12	15.41	8.73	Ø 0.07 THRU ALL Ø 0.12 X 100°
H1	16.00	0.43	Ø 0.07 THRU ALL Ø 0.12 X 100°
H2	16.00	3.03	Ø 0.07 THRU ALL Ø 0.12 X 100°
H3	16.00	5.63	Ø 0.07 THRU ALL Ø 0.12 X 100°
H4	16.00	8.23	Ø 0.07 THRU ALL Ø 0.12 X 100°
H5	16.00	10.83	Ø 0.07 THRU ALL Ø 0.12 X 100°
H6	16.00	13.43	Ø 0.07 THRU ALL Ø 0.12 X 100°

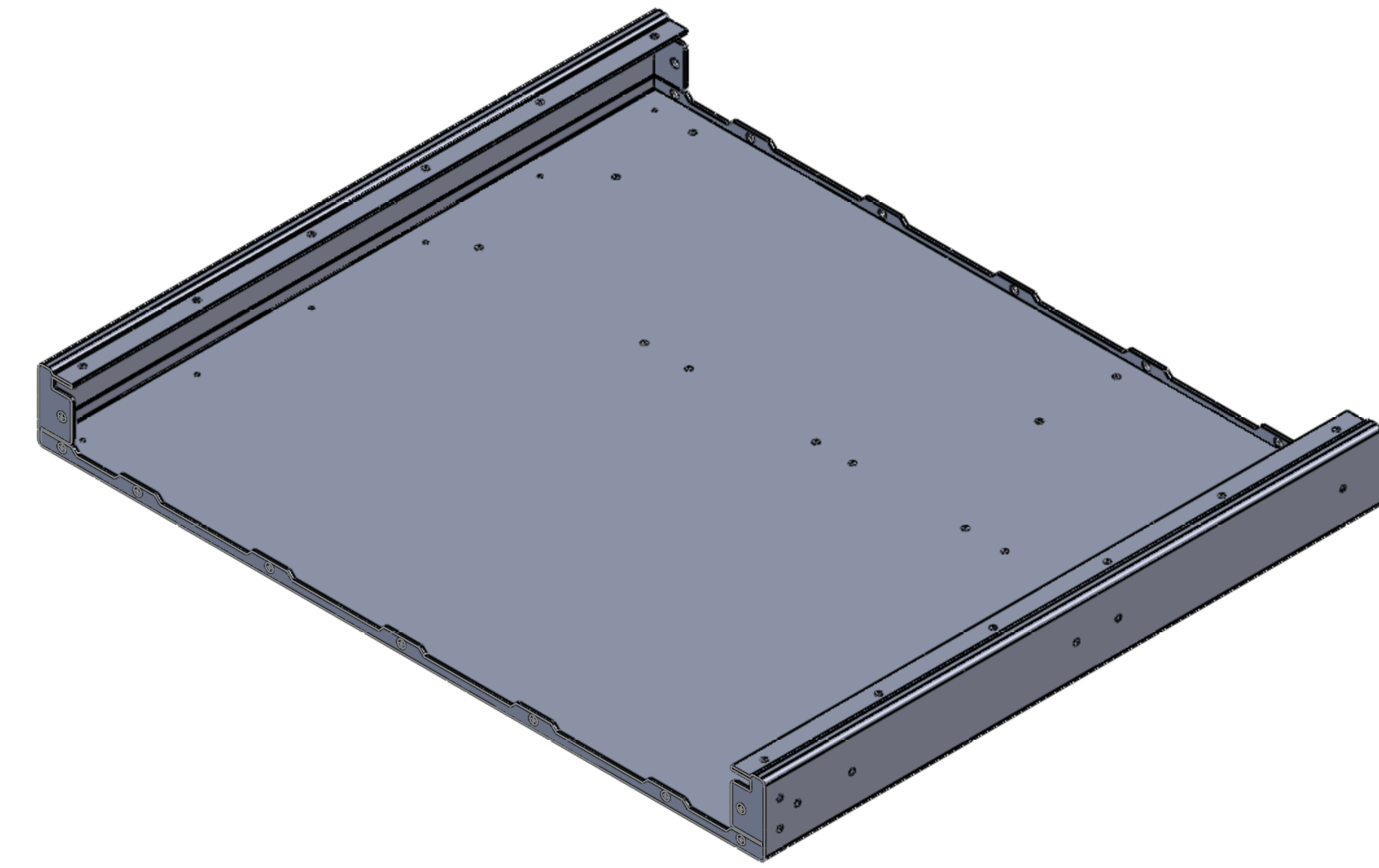
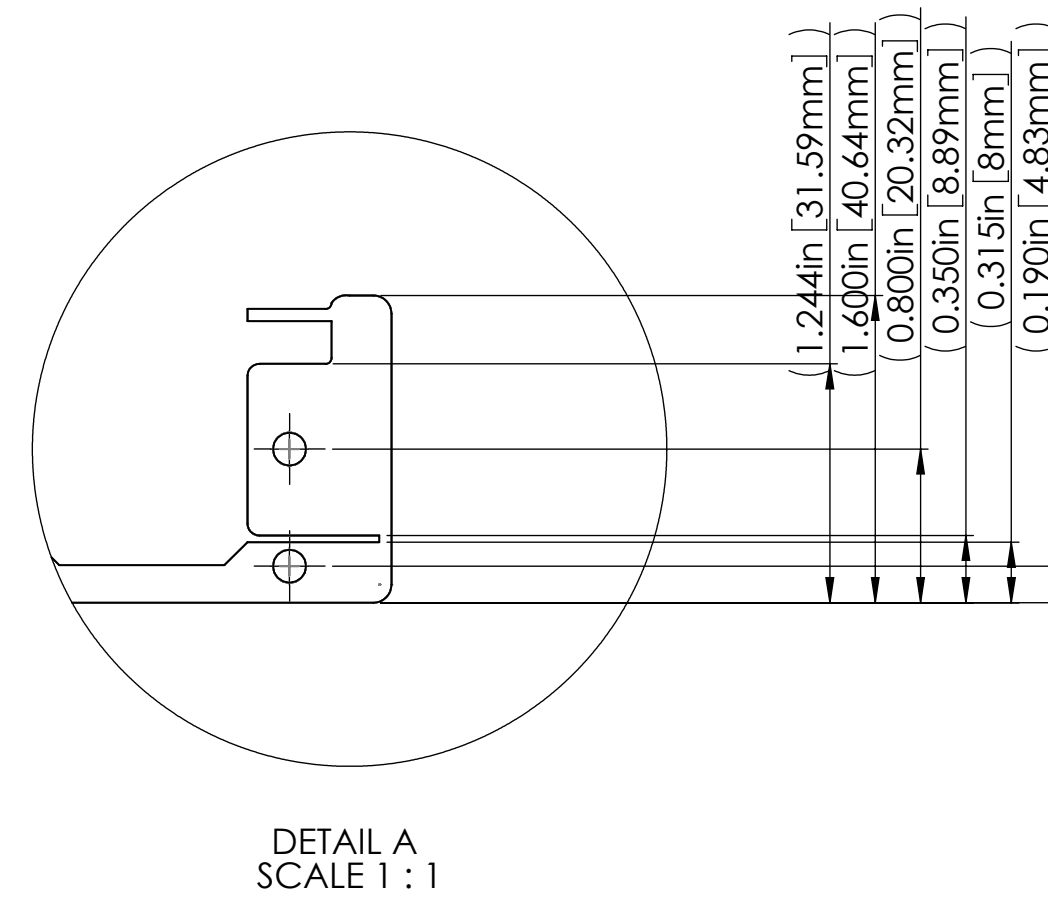
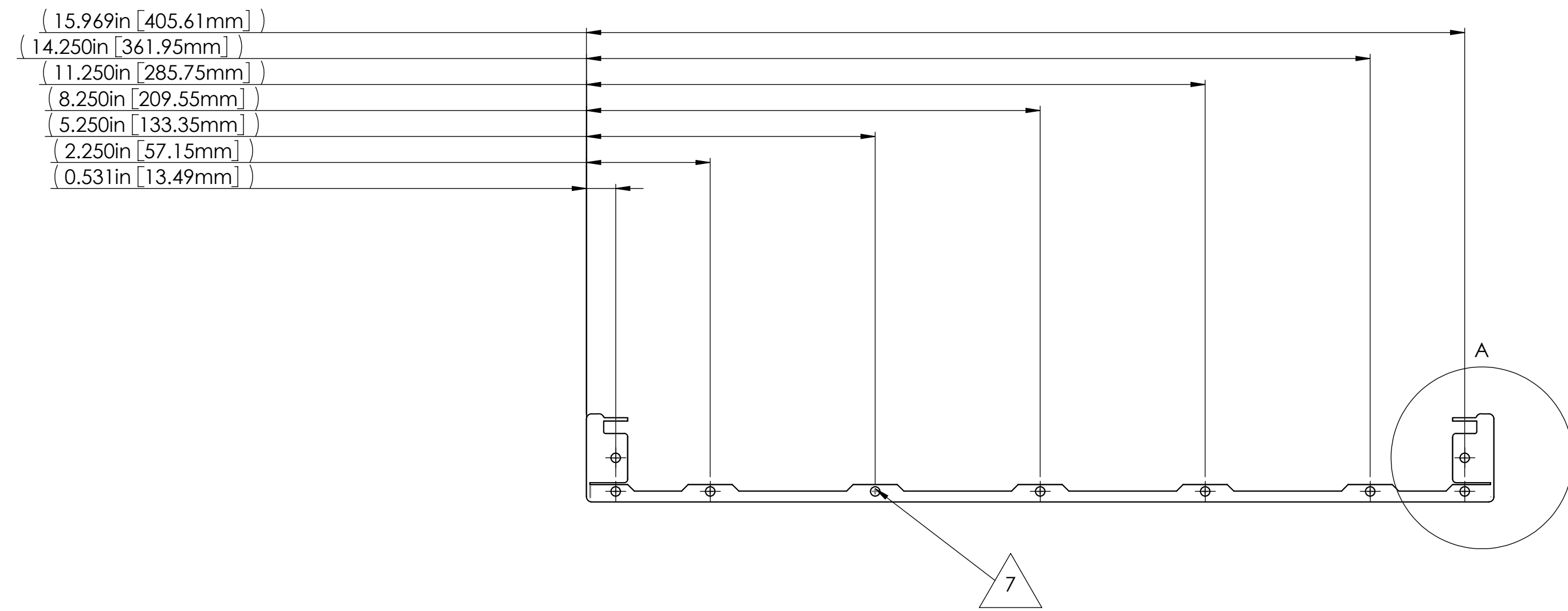
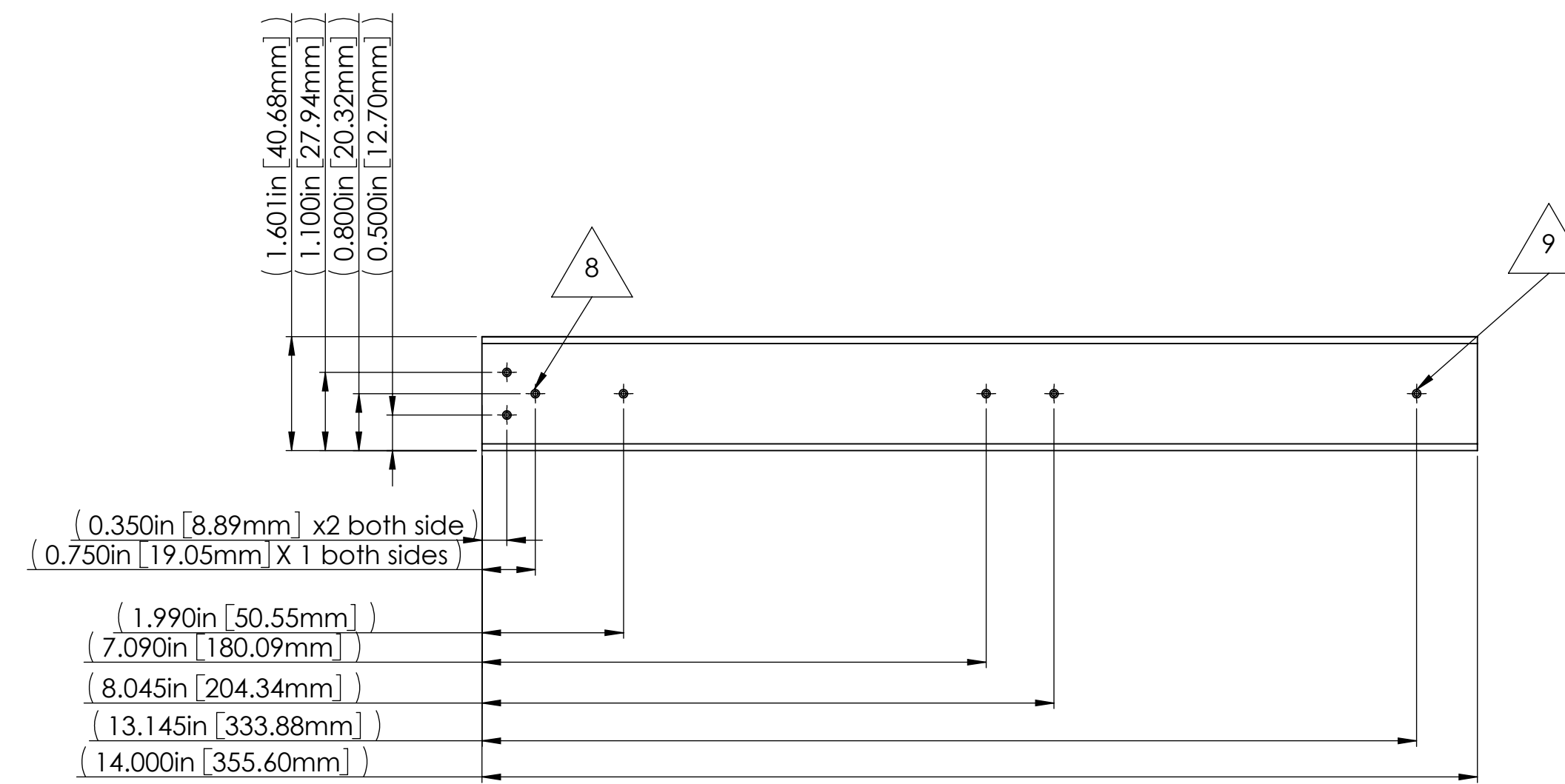
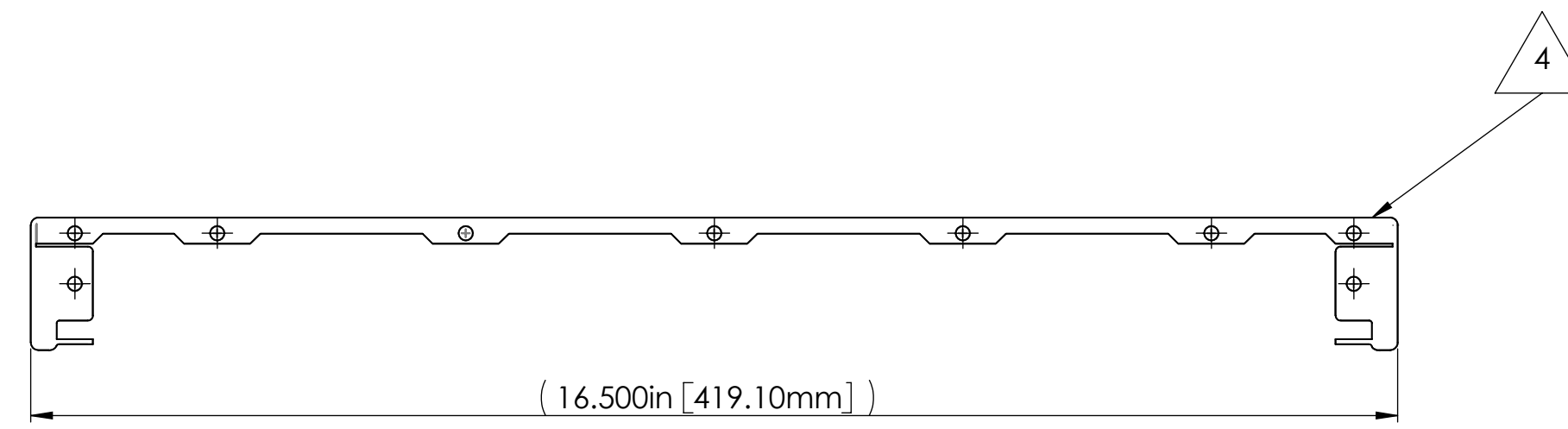

NOTES: (UNLESS OTHERWISE SPECIFIED)

- Dimensions inches.
- Remove all sharp edges, R.02 min
- Base unit has Hamilton part number D070012-A
- Hole pattern is to be added after base unit is constructed.  
- use countersunk holes
- Ø 0.172 install farside before forming pem#F-440-1(9x)
- Ø 0.172 install farside before forming pem#F-440-1(12x)
- Ø 0.172 install farside before forming pem#F-440-1(9x)
- Ø 0.189 install farside before forming pem#CLS-632-1(6x)
- Ø 0.172 install farside before forming pem#F-440-1(4x)

ITEM NO.	PART NUMBER	DESCRIPTION	QTY.
1	00_01_chassis_V4		1

UNLESS OTHERWISE SPECIFIED:  
DIMENSIONS ARE IN INCHES  
TOLERANCES:  
FRACTIONAL  
DECIMAL  
HOLE POSITION  
HOLE SIZE  
HOLE POSITION  
HOLE SIZE

DATE: 3.18.2010  
DRAWN: LDI  
CHECKED: [blank]  
ENG APPR: [blank]  
MFG APPR: [blank]  
G.A.  
COMMENTS:

PROPERTY AND CONFIDENTIALITY INFORMATION CONTAINED HEREIN IS THE PROPERTY OF HAMILTON COMPANY. NO PART OF THIS DOCUMENT IS TO BE REPRODUCED OR TRANSMITTED IN ANY FORM OR BY ANY MEANS, ELECTRONIC OR MECHANICAL, INCLUDING PHOTOCOPYING, RECORDING, OR BY ANY INFORMATION STORAGE AND RETRIEVAL SYSTEM, WITHOUT THE WRITTEN PERMISSION OF HAMILTON COMPANY. HAMILTON COMPANY PART NUMBER: 00\_01\_001

DATE: 3.18.2010  
DRAWN: LDI  
CHECKED: [blank]  
ENG APPR: [blank]  
MFG APPR: [blank]  
G.A.  
COMMENTS:

SIZE: DWG. NO. E D070012 V4  
SCALE: 1:5 WEIGHT: [blank]  
SHEET 1 OF 1